



Designation: D7478/D7478M-08^{ε1} Designation: D7478/D7478M – 11

Standard Specification for Heavy Duty Sheathed Wood Crates¹

This standard is issued under the fixed designation D7478/D7478M; the number immediately following the designation indicates the year of original adoption or, in the case of revision, the year of last revision. A number in parentheses indicates the year of last reapproval. A superscript epsilon (ϵ) indicates an editorial change since the last revision or reapproval.

~~^{ε1}Note— Subsection 6.2.5 was editorially corrected in April 2009.~~

1. Scope

1.1 This specification covers requirements for two types and two classes of sheathed crates each of which may have two base styles. The crates are designed for net loads not exceeding 30 000 pounds lb [13 607 kg] and to withstand the most severe overseas shipping and storage conditions.

1.2 The crates described by this specification are intended to protect items from atmospheric elements during shipment and storage. They are designed to withstand the rough handling of logistic operations including stacking and outside storage for a prolonged period.

1.3 Class 1 and 2 crates may be used interchangeably as desired. However, the Class 2 crate should be used when weight is a prime consideration, as the lack of diagonals and thinner plywood sheathing results in a lighter crate.

1.4 Demountable crates, Type II, should be used whenever it is expected that the contained item will require reshipping to another destination.

1.5 Sill bases, Style B, are intended for items that project below their mounting points, such as disassembled vehicles.

1.6 If the use of other construction method or techniques is acceptable and permitted (see 5.10), the resulting packaging systems shall be of equal or better performance than would result from the use of these specified materials and procedures. The appropriate distribution cycle, specified in Practice D4169 can be used to develop comparative procedures and criteria.

1.7 The values stated in either SI units or inch-pound units are to be regarded separately as standard. The values stated in each system may not be exact equivalents; therefore, each system shall be used independently of the other. Combining values from the two systems may result in non-conformance with the standard. See IEEE/ASTM SI 10 for conversion of units.

1.8 *This standard does not purport to address all of the safety concerns, if any, associated with its use. It is the responsibility of the user of this standard to establish appropriate safety and health practices and determine the applicability of regulatory limitations prior to use.*

2. Referenced Documents

[ASTM D7478/D7478M-11](#)

<http://www.astm.org/standards/sist/87e1e122-7bd6-4953-9c54-946a43627821/astm-d7478-d7478m-11>

D996 Terminology of Packaging and Distribution Environments

D3953 Specification for Strapping, Flat Steel and Seals

D4169 Practice for Performance Testing of Shipping Containers and Systems

D4442 Test Methods for Direct Moisture Content Measurement of Wood and Wood-Base Materials

D4675 Guide for Selection and Use of Flat Strapping Materials

D6199 Practice for Quality of Wood Members of Containers and Pallets

D6253 Practice for Treatment and/or Marking of Wood Packaging Materials

F1667 ~~Specification for Driven Fasteners: Nails, Spikes, and Staples~~ Specification for Driven Fasteners: Nails, Spikes, and Staples

IEEE/ASTM SI 10 Standard for Use of International System of Units (SI): The Modern Metric System

2.2 National Institute of Standards and Technology (NIST) Standards:

PS 1 Voluntary Product Standard, Structural Plywood³

¹ This specification is under the jurisdiction of ASTM Committee D10 on Packaging and is the direct responsibility of Subcommittee D10.12 on Shipping Containers, Crates, Pallets, Skids and Related Structures.

Current edition approved Oct. 1, 2008. Published November 2008. DOI: 10.1520/D7478_D7478M-08E01.

Current edition approved Nov. 1, 2011. Published January 2012. Originally approved in 2008. Last previous edition approved in 2008 as D7478/D7478M-08. DOI: 10.1520/D7478_D7478M-11.

² For referenced ASTM standards, visit the ASTM website, www.astm.org, or contact ASTM Customer Service at service@astm.org. For Annual Book of ASTM Standards volume information, refer to the standard's Document Summary page on the ASTM website.

³ Available from APA, The Engineered Wood Association, 7011 South 19th St., Tacoma, WA 98466-5399, http://www.apawood.org.

PS 20 American Softwood Lumber Standard⁴

2.3 *Hardwood Plywood and Veneer Association Standard:*⁵

~~ANSI/HPVA HP-1~~ANSI/HPVA HP-1-2004 American National Standard for Hardwood and Decorative Plywood

2.4 *National Hardwood Lumber Association (NHLA) Standard:*⁶

~~Rules~~NHLA Rules for the Measurement and Inspection of Hardwood and Cypress

iTeh Standards (<https://standards.iteh.ai>) Document Preview

[ASTM D7478/D7478M-11](#)

<https://standards.iteh.ai/catalog/standards/sist/87e1e122-7bd6-4953-9c54-946a43627821/astm-d7478-d7478m-11>

⁴ Available from American Lumber Standards Committee, Inc., (ALSC), P.O. Box 210, Germantown, MD 20875-0210, <http://www.alsc.org>.

⁵ Available from Hardwood Plywood and Veneer Association (HPVA), P.O. Box 2789, Reston, VA 22090-0789, <http://www.hpva.org>.

⁶ Available from National Hardwood Lumber Association (NHLA), 6830 Raleigh LaGrange Rd., Memphis, TN 38134, <http://www.natllhardwood.org>.

~~2.5 ASME/ANSI Standards:~~ASME Standards:⁷

~~B18.2.1 Square and Hex Bolts and Screws Inch Series~~ ASME B18.2.1-2010 Square, Hex, Heavy Hex, and Askew Head Bolts and Hex, Heavy Hex, Hex Flange, Lobed Head, and Lag Screws (Inch Series)

~~ASME B18.2.2-2010 Nuts for General Applications: Machine Screw Nuts, Hex, Square, Hex Flange, and Coupling Nuts (Inch Series)~~

~~ASME B18.2.3.8M - 1981 Metric Hex Lag Screws~~

~~ASME B18.2.4.3M-1979 Metric Slotted Hex Nuts~~

~~B18.5-ASME B18.5-2008 Round Head Bolts (Inch Series)~~

~~B18.22.1 (B18.22M) Plain Washers~~ ASME B18.5.2.2M-1982 Metric Round head Square Neck Bolts

~~ASME B18.22M-1981 Metric Plain Washers~~

~~ASME B18.21.1-2009 Washers: Helical Spring-Lock, Tooth Lock, and Plain Washers (Inch Series)~~

2.6 International Standard:⁸

ISPM 15 International Standards for Phytosanitary Measures Publication No. 15 (ISPM 15), Regulation of Wood Packaging Material in International Trade

3. Terminology

3.1 *Definitions*—General definitions for packaging and distribution environments are found in Terminology D996.

3.2 *Definitions of Terms Specific to This Standard:*

3.2.1 ~~The Standard~~—The crate component parts discussed herein were selected on the basis of part function. Alternate names are sometimes used by industry.

3.2.2.1 *diagonals*—diagonals are frame members positioned between parallel frame members and placed at nearly 45° angles to them. Diagonals serve as braces and ensure rigidity in the crate.

3.2.3

3.2.2 *end frame members*—end frame members are similar to side frame members but perpendicular to the long dimension.

3.2.4

3.2.3 *filler strips*—filler strips are boards placed across the ends of thin, non-load-bearing floorboards, which serve to fill the space below the lower frame member of the crate sides.

3.2.5

3.2.4 *frame members*—frame members are those parts which form the fundamental crate structure upon which the strength and rigidity of a lumber-sheathed crate depends.

3.2.6

3.2.5 *hanger-metal*—hanger-metal is a metal nailed strap used to aid in support of the intermediate sill in sill-type bases.

3.2.7

3.2.6 *headers*—headers are either transverse members at each end of skid bases or longitudinal members at each end of top joists. Headers in bases serve to hold the base together as a unit, to transfer loads to outside skids, and to provide a fastening member for end panels. Headers in top panels serve to position and support joists and to provide a fastening member for side panels.

3.2.8

3.2.7 *horizontal braces*—horizontal braces are members positioned between struts and parallel to the upper and lower frame members and serve to reduce the unsupported span of the sheathing.

3.2.9

3.2.8 *joists*—joists are members extending across the crate underneath the top, which serve to support and transfer vertical stacking loads to the side panels. Joists also serve to prevent crushing or buckling of crate tops when slings or grab hooks are used.

3.2.10

3.2.9 *lag screw strap*—lag screw strap is a metal reinforcing strap used on bolted crates sides and ends to reinforce and increase lag screw lateral resistance.

3.2.11

3.2.10 *load-bearing floorboards*—load-bearing floorboards are transverse base members which serve to distribute and transfer loads to the outside skids.

3.2.12

3.2.11 *rubbing strips*—rubbing strips are longitudinal members nailed to the skid bottom to provide for sling and forklift truck handling.

3.2.13

3.2.12 *sheathing*—sheathing is the plywood or boards nailed to the frame members and enclose the crate. Sheathing used on the top panels is called top sheathing; that used on the side or end panels is called side or end sheathing; that nailed to the top of

⁷ Available from American Society of Mechanical Engineers (ASME), ASME International Headquarters, Three Park Ave., New York, NY 10016-5990, <http://www.asme.org>.

⁸ Available from the International Plant Protection Convention, www.ippc.int

skids is called flooring; and that nailed to the bottom of sills is called bottom sheathing.

~~3.2.14~~

~~3.2.13~~ *side frame members*—side frame members are the members of the crate top, without joists, which are parallel to the long dimension and serve as fastening members and to tie the crate construction together.

~~3.2.15~~

~~3.2.14~~ *sill bridging*—sill bridging are members of the same depth as the sills, which are inserted at right angles to the intermediate sills, and serve to prevent lateral sill turning or buckling.

~~3.2.16~~

~~3.2.15~~ *sills*—sills are the members, which with sill bridging form the frame work of sill-type bases. Sills carry and transfer loads to side panels and serve as fastening members. There are side, end, and intermediate sills.

~~3.2.17~~

~~3.2.16~~ *skids*—skids are longitudinal members attached to the crate bottom, which serve to support and transfer the load to the side panels.

~~3.2.18~~

~~3.2.17~~ *sleepers*—sleepers are members underneath the floor of skid-type bases to which the item is anchored (through the floor) so that the tie-down stress will be distributed.

~~3.2.19~~

~~3.2.18~~ *struts*—struts are vertical frame members, placed between the side and end panels' upper and lower frame members, and serve as columns for supporting vertical stacking loads. The end struts are sometimes referred to as corner posts.

~~3.2.20~~

~~3.2.19~~ *upper and lower frame members*—upper and lower frame members are those horizontal members at the top and bottom of the side and end panels which serve to tie the construction together.

~~3.2.21~~

~~3.2.20~~ *vertical joist supports*—vertical joist supports are vertical members attached to the crate sides inside face, which serve to support the joists and assist the struts in supporting vertical stacking loads.

4. Classification

4.1 Crates shall be of the following types, classes, and styles:

4.2 *Type*:

4.2.1 *Type I*—Nailed.

4.2.2 *Type II*—Bolted.

4.3 *Class*:

4.3.1 *Class 1*—Lumber sheathed.

4.3.2 *Class 2*—Plywood sheathed.

4.4 *Style*: <https://standards.iteh.ai/catalog/standards/sist/87e1e122-7bd6-4953-9c54-946a43627821/astm-d7478-d7478m-11>

4.4.1 *Style A*—Skid base.

4.4.2 *Style B*—Sill base.

5. Ordering Information

5.1 Purchasers should select the preferred permitted options and include the following information in procurement documents:

5.2 Specification title, number, and date.

5.3 Crate type, class, and style (see Section 4).

5.4 Contents weight.

5.5 Crate dimensions specified in order of length by width by depth.

5.6 When inspection doors are required.

5.7 When top, sides, and ends shall be assembled with nails and the entire assembly bolted to the base.

5.8 Whether crates are to be shipped assembled or knocked down.

5.9 Whether other construction methods or techniques are acceptable and permitted (see 1.6).

5.10 Whether proof that other constructions methods or techniques are acceptable (see 1.6) is required.

5.11 If packaging is other than as specified.

5.12 When ISPM 15 compliance is required (see 12.1).

6. General Requirements

6.1 *Crate Loading*—When crates are furnished as filled containers, the extent of contents disassembly, the anchoring, blocking, and lifting attachments application shall be in accordance with this specification's Supplemental Requirements.

6.2 *Dimensions*:

6.2.1 *Inside Dimension*—Inside crate length or width is the distance between opposite struts inner surfaces. Inside height is the distance between skid base floorboards or sill bases' sill tops and the underside of top joists or framing members.

6.2.2 *Outside Dimensions*—Outside dimensions are the crate, or its contents, overall length, width, and height, whichever is

greater. Actual dimensions, except in designing, are corrected whole inches [25 mm increments], any fraction less than ½ in. [13 mm] being disregarded, and any fraction of ½ in. [13 mm] or greater being considered a full inch [25 mm increment].

6.2.3 *Cubic Displacement*—Crate cubic displacement is calculated from the outside dimensions in inches [millimetres] and is stated in cubic feet [cubic metres].

6.2.4 *Limitations*—The crate exterior dimensions shall not exceed the following limitations:

6.2.4.1 *Length*—30 ft [9144 mm].

6.2.4.2 *Width*—9 ft [2743 mm].

6.2.4.3 *Height*—10 ft [3048 mm].

6.2.5 *Interior Clearance*—A clearance of not less than 2 in. [50 mm] shall be allowed between the item and the closest side, end, or top crate member. Additional clearances may be provided for shock-mounted items. Protruding parts at the top may be allowed to extend between joists; joist spacing may be adjusted slightly to accommodate projections.

7. Materials and Manufacture

7.1 *Materials*—Materials shall be as specified herein. Materials not specified shall be selected by the contractor or crate builder and shall be subject to all provisions of this specification (see Section 11). Materials shall be free of defects, which adversely affect performance or serviceability of the finished product.

7.2 *Lumber*—Lumber components shall conform to Practice D6199, PS 20, or the NHLA ~~rules~~ Rules. All lumber sizes specified herein shall be nominal and shall be the minimum acceptable sizes for lumber components. Lumber components shall have a target thickness and width uniform in dimension and 50 % of components shall meet or exceed the target dimensions at the time of component manufacture.

7.3 *Plywood*—Plywood shall conform to PS 1 ~~or ANSI/HPVA HP-1~~ or ANSI/HPVA HP-1-2004. All panels shall be bonded with moisture resistant adhesive and be identified as either Exposure 1 or Exterior.

7.4 *Fasteners*—Fasteners are classified as driven nails, bolts, lag bolts, wood screws, and metal strapping.

7.4.1 *Nails*—Nails shall be in accordance with Specification F1667 and other industry standards. Nails are classified as plain-shank, helically threaded, annularly threaded, fluted, or twisted square wire.

7.4.2 *Staples*—Staples have either round-wire or approximately square-wire legs, referring to the cross-sectional shape of the wire. Staples should be made of low carbon steel wire and galvanized.

7.4.3 *Bolts, Lag Bolts, Nuts and Washers*—~~Bolts, lag bolts and nuts shall conform to ASME/ANSI B18.2.1, ASME/ANSI B18.5 and other industry standards. Washers shall conform to ASME B18.22.1 (B18.22M) and other industry standards. Standard steel carriage bolts can be used in any of three styles: standard, slotted, or large head.~~ Bolts, lag bolts, nuts and washers shall conform to industry standards, including the following:

ASME B18.2.1-2010 (ASME B18.2.3.8M-1981),

ASME B18.5-2008 (ASME B18.5.2.2M-1982),

ASME B18.2.2-2010 (ASME B18.2.4.3M-1979), and

ASME B18.21.1-2009 (ASME B18.22M-1981).

Standard steel carriage bolts can be used in any of three styles: standard, slotted, or large head.

7.4.4 *Wood Screws*—Screws shall be inserted into the crate components to be assembled with a screwdriver or screw motion machine tool. Approximately two-thirds of the screw length and seven times the shank diameter shall be the penetration length into the fastening member. Where pre-drilling is required, the maximum lead-hole diameter shall be the fastener-shank diameter, and the pilot-hole diameter shall not be larger than the thread-root diameter.

7.4.5 *Strapping*—Strapping shall conform to Specification D3953, ~~Type 1 or 2 as applicable. Finish shall be A, B, or C.~~ and as specified herein (8.7.5.3). Finish shall be A, B, or C as applicable. Refer to Guide D4675 for additional guidelines.

7.5 *Protective Covering*—Felt or film.

8. Construction

8.1 *Nailing Procedure*—Sinkers, coolers, corkers, or common nails shall be used. Nail sizes specified for crate fabrication are based on Practice D6199 Group I and II Woods. When Group III or IV Woods are used, nail sizes may be one-penny size smaller than those specified. The nail patterns to be used for nailing two flat pieces of lumber shall conform to the details shown in Fig. 1 or as specified herein. Unless otherwise specified herein, the following requirements shall determine nail size, placement, and quantity.

8.1.1 All adjacent crate members shall be securely fastened nailed to each other, either directly or by means of the covering.

8.1.2 All nails that are not to be clinched shall be cement-coated.

8.1.3 Nails shall be driven through the thinner member into the thicker member wherever possible.

8.1.4 Nails for fastening plywood to framing shall be clinched at least ¼ in. [6 mm]. Nail heads shall always be on the plywood side.

8.1.5 When the flat faces of lumber pieces are nailed together and the combined thickness is 3 in. [76 mm] or less (except for top joists and covering material), nails shall be long enough to pass through both thicknesses and shall be clinched not less than ¼ in. [6 mm] or more than ⅜ in. [10 mm].

8.1.6 When the flat faces of lumber pieces are nailed together and the combined thickness is more than 3 in. [76 mm] or when

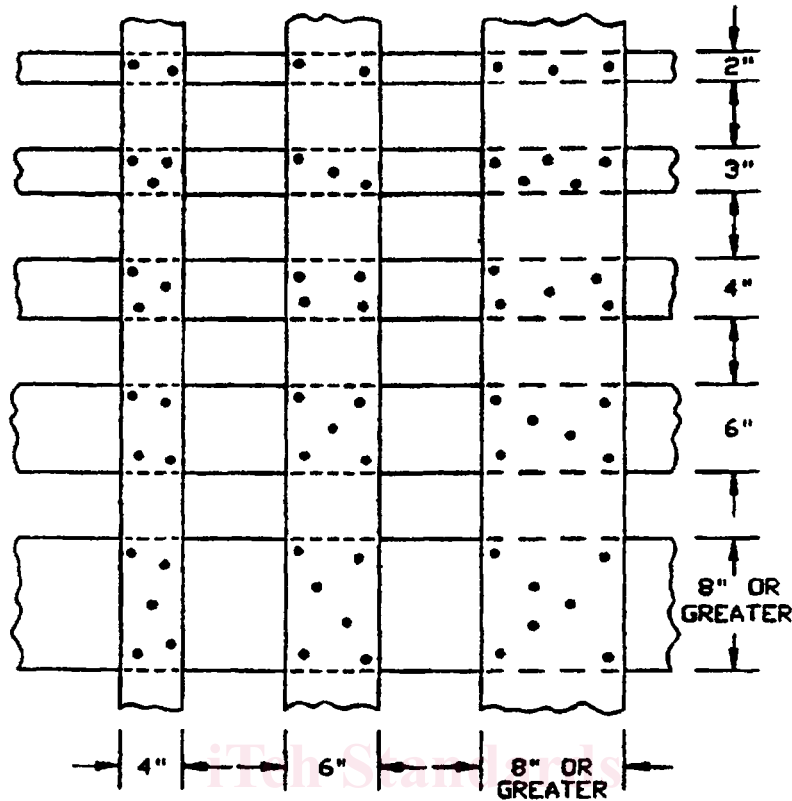

NOTE—All widths nominal. Use similar nailing patterns when boards cross at angles other than 90°.

FIG. 1 Nailing Schedule for Boards Crossing at Right Angles

the flat face of one or more pieces is nailed to the edge or end face of another, nails shall not be clinched. The nail portion in the thicker piece shall not be less than 2 times the nail length in the thinner piece for ten-penny (3 in. [76 mm]) nails and smaller, and not less than 1½ in. [38 mm] for twelve-penny (3¼ in. [82 mm]) nails and larger.

8.1.7 When diamond-point nails cause crate member splitting, the nails shall be slightly blunted. When blunting does not prevent the splitting, holes slightly smaller than the nail diameter shall be drilled for each nail.

8.1.8 Nails shall be driven so that neither the head nor the point projects above the wood surface. Occasional over-driving will be permitted, but nails shall not be over-driven more than one-eighth the thickness of the piece holding the head.

8.1.9 Nails shall be positioned not less than the thickness of the piece from the end not less than one-half the thickness of the piece from the side edge of the lumber whenever possible. Nails driven into the lumber side edge shall be centered on the side edge.

8.1.10 Nails securing plywood sheathing to frame members shall be spaced as shown in Fig. 2. Machine driven nails having a definite head may be used for securing plywood sheathing providing they meet size requirements specified herein.

8.2 *Stapling*—Staples may be used to fasten sheathing to frame members. Staples shall not be used for base fabrication, fastening framing members to each other, or for crate assembly. Staples shall have crowns of not less than ⅜ in. [10 mm] wide and shall have a wire diameter of not less than 0.062 in. [16 gage, 1.59 mm]. Straight leg staples shall be long enough to provide a minimum ¼-in. [6-mm] clinch; divergent point staples shall not be less than 1 in. [25 mm] long. Staple spacing shall be the same as for nails specified herein. Staples shall always be driven from the plywood side.

8.3 *Bolt Application*—Holes shall be pre-bored to receive carriage bolts and shall be no less than the diameter of the bolt. The lead holes for lag bolts shall be the same diameter as the shank, even though the threaded portion may have a greater diameter than the shank, and shall be as shown in Table 1. Lag bolts shall be placed by being turned in their holes the full bolt length and shall not be driven in with a hammer or by any similar means. If, for any reason, the thread in the wood is stripped when the lag bolts are placed, the lag bolt shall be removed and placed in a new hole near the old position. A flat washer shall be used under each lag bolt head and under each carriage bolt nut.

8.4 *Splices, Butt Joints and Lamination*—Splices and butt joints made in frame members and skids of long crates shall be as shown in Fig. 3. Lamination of wood is shown in Fig. 4.

8.5 *Inspection Doors*—When specified (see 5.6), one or more inspection or access doors shall be provided. Door size and location shall be specified by the purchaser and will be used for interim inspection or servicing of contents. Doors shall be built without cutting the frame members and shall be hinged at the top and fastened by lag screws at the sides and bottom as shown in Fig. 5. Cleats and stops shall be made of 1-in. [19-mm] material. Doors shall be made of the same type and thickness as material

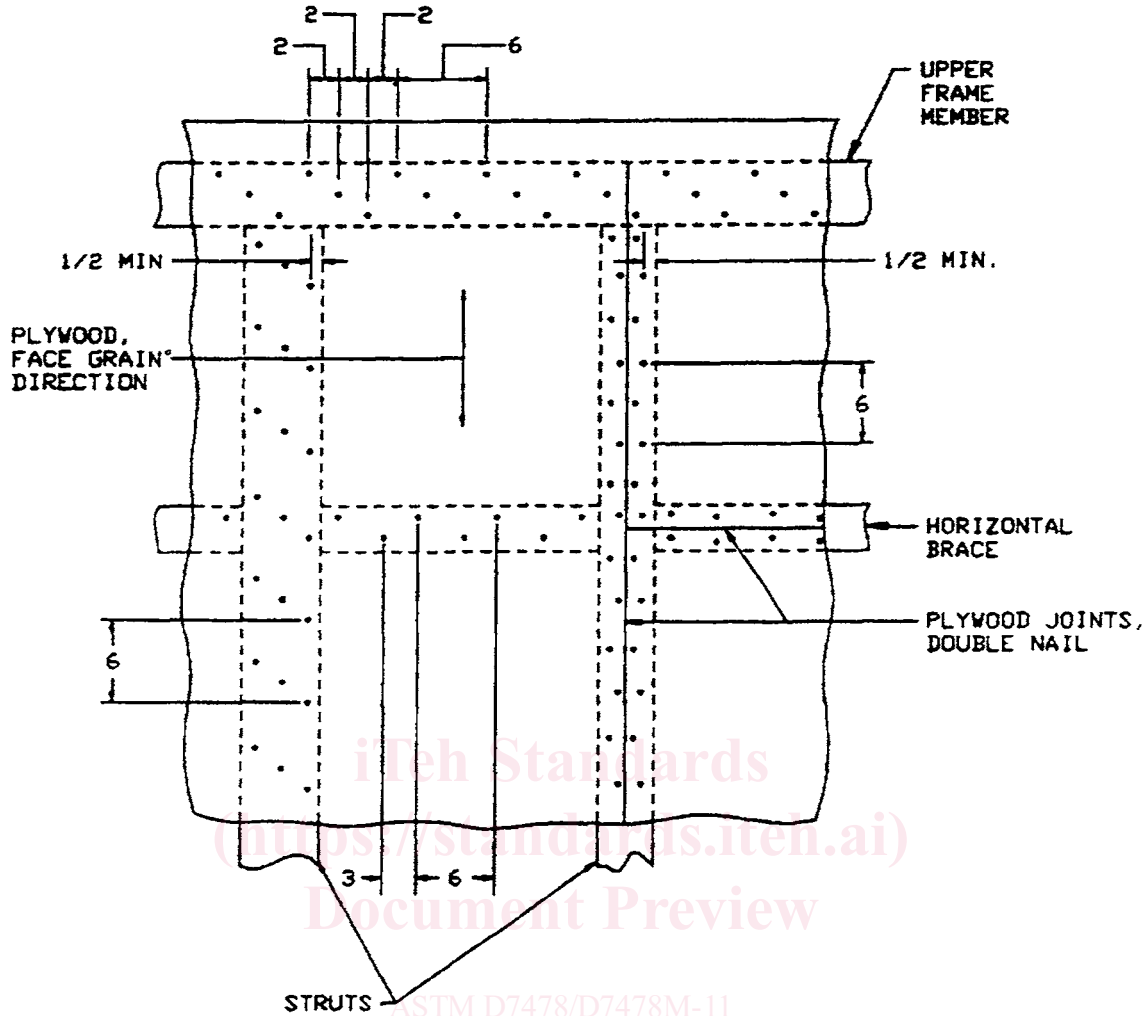

NOTE—All dimensions in inches. Three rows of nails for all members over 4 in. wide. Two rows of nails for all members up to 4 in. wide.

FIG. 2 Fabrication Nailing Plywood Sheathing

TABLE 1 Lag Bolt Lead Hole Sizes

Lag Bolt Threaded Portion Diameter		Lead Hole Diameter, in. [mm]			
		Group I, II, & III Woods		Group IV Woods	
in.	[mm]	in.	[mm]	in.	[mm]
1/4	6	3/16	5	3/16	5
5/16	8	1/4	6	1/4	6
3/8	10	1/4	6	5/16	8
1/2	12	3/8	1	7/16	11
5/8	16	3/8	10	1/2	12
3/4	19	1/2	12	5/8	16

used for sheathing. Holes shall be provided through the door and an adjacent frame member for a seal wire and lead seal bearing the inspectors' stamp. When hinges with exposed screws are used, the hinge side of the door shall also be sealed.

8.6 *Ventilation*—All lumber and plywood sheathed crates shall be provided with ventilation holes or slots which shall be located at each end, or at ends and sides, or around the perimeter (Table 2). These ventilating holes or slots shall be located immediately below the top frame member, and be provided with a baffle as shown in Fig. 6 when slots are used in plywood sheathed crates, or when holes are in clusters in lumber sheathed crates. Single holes drilled without baffles shall be sloped at 45° to drain outward. No holes or slots shall be cut in any frame member.

8.7 *Class 1 Crates*—Class 1 crates may be either bolted or nailed. Bolted crates shall be designed so that the base, sides, ends, and top may be assembled to each other with lag bolts in order that the crate can be readily disassembled and, if desired, reassembled without major damage to the parts. Nailed crates are assembled with nails and straps, are not easily disassembled, and because of probable damage during disassembly, are not generally reused. When specified (see Section 5), a combination of top,

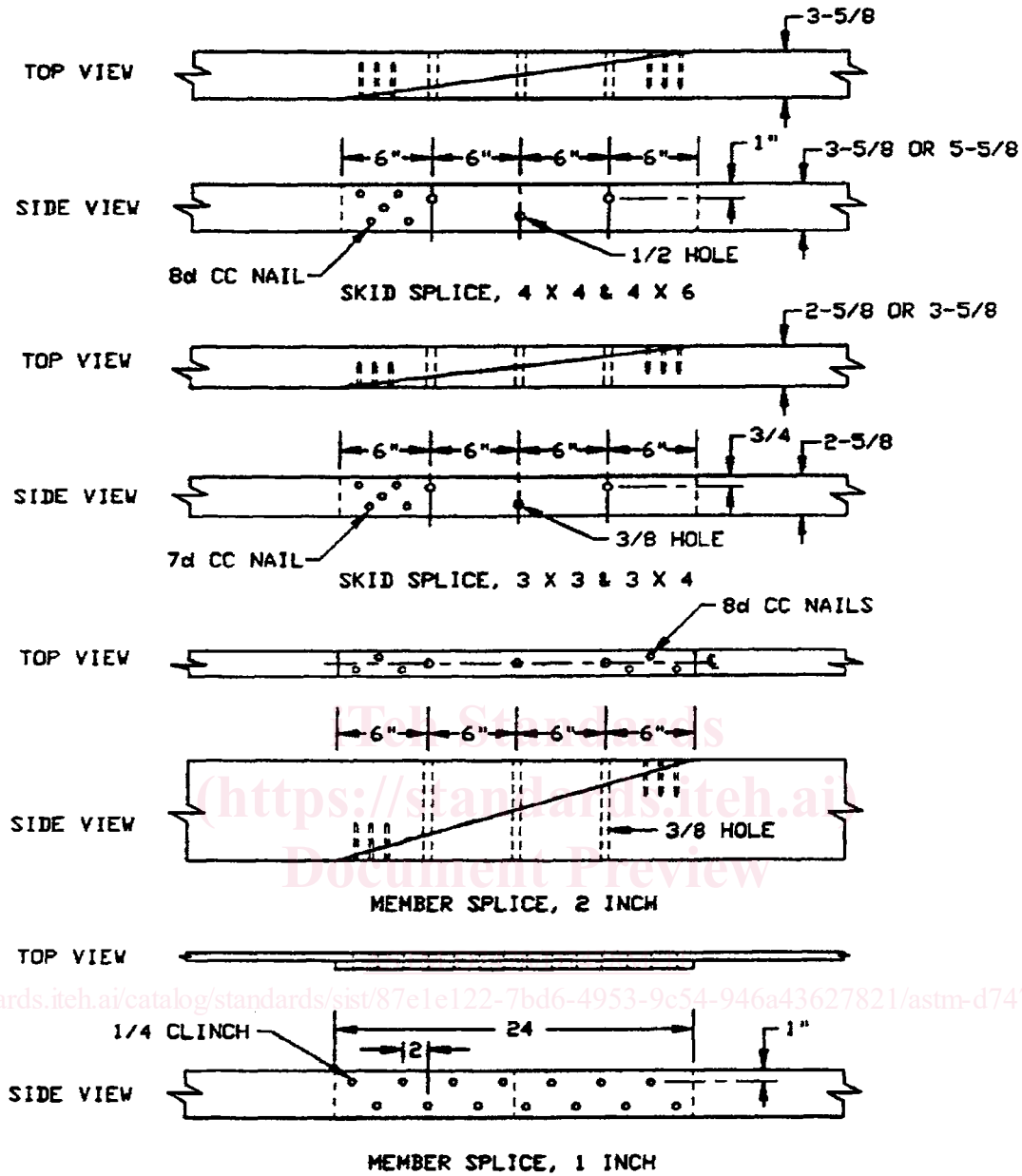

NOTE—Use carriage bolts. All dimensions in inches.

FIG. 3 Splicing of Members

side, and end panels may be fabricated and assembled to each other as specified for nailed crates, and the unit fastened to the base as specified for bolted crates.

8.7.1 *Bases*—Bases shall be designed to support the weight of the crated article only when the sides and ends are fastened in place (see Section 10).

8.7.1.1 *Style A (Skid-Type)*—Style A bases shall consist of longitudinal skids and rubbing strips, headers, load-bearing floorboards, and flooring as shown on Figs. 7 and 8. Details of construction shall be the same for bolted and nailed crates.

(1) *Skids*—Any species of wood except Group I shall be used for skids. Skids shall be spaced no farther apart than 48 in. [1219 mm], center to center, across the base width. Minimum size shall be as shown in Table 3. When either the length or net load exceeds the maximum shown, the next larger skid shall be used. When necessary, skids may be spliced or laminated according to the details shown in Fig. 3 or Fig. 4, but the use of 2 × 4 in. [38 × 89 mm] skids shall be limited to such lengths that no splicing would be required. Whenever possible, splices shall be made not more than one-third of the base length from the skid ends and the splice locations alternated in adjacent skids. To prevent splitting, all skids shall have a carriage bolt placed crosswise and 2 to 3 in. [51 to 76 mm] back from each skid end as shown in Fig. 7 and 24. Bolt sizes shall comply with Table 4.

(2) *Rubbing Strip for Skids*—Rubbing strips of 3-in. [64-mm] thick lumber, the same width as the skids, shall be attached to

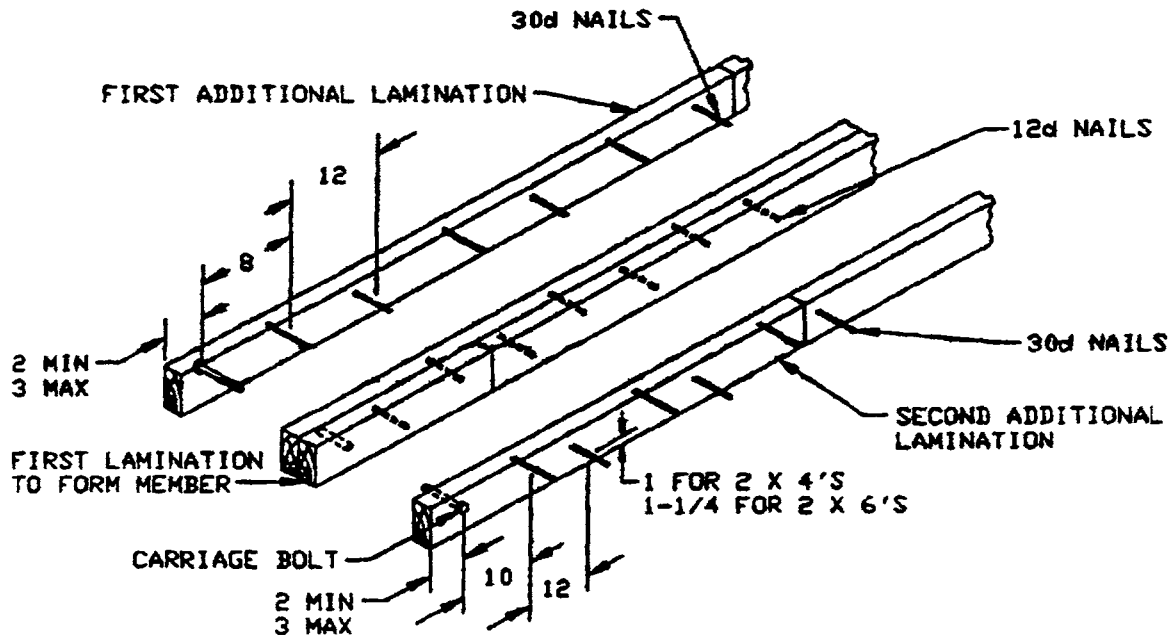

STAGGERING JOINTS TOP VIEW

LAMINATION OF SKID OR SILL MEMBERS
(2 INCH THICK MATERIAL)

NOTE—All dimensions in inches.
FIG. 4 Laminating Method

the skids with two staggered rows of nails spaced 12 in. [305 mm] apart in each row. The nails shall be driven through the rubbing strip into the skid. The nails shall be long enough to penetrate approximately 70 % (minimum) of the skid thickness and shall not protrude through the skid. The strips shall be beveled 45° full depth at sling and forklift openings. Openings in the rubbing strips for forklift-truck access shall be 12 in. [305 mm] in length, 28 in. [711 mm] center-to-center, and positioned to straddle the loaded crate center of balance. Sling openings not less than 4 in. [102 mm] in length, and preferably 8 in. [203 mm], shall be provided at the rubbing strip ends where permitted by the crate length and by the location of the forklift-truck access openings. No rubbing strips center pieces shall be less than 16 in. [406 mm] in length. On crates 5 ft [1524 mm] and less in length, the forklift openings shall be omitted; end sling openings shall not be less than 6 in. [152 mm] long and shall serve as both forklift and sling openings.

(3) *Headers*—Headers shall be placed at each end of the base and shall be bolted to each skid with one carriage bolt (Figs. 9 and 10). Header and bolts sizes shall be as shown in Table 4. Headers shall be a single piece and not built up to two or more pieces to meet the dimension requirements. Headers shall be placed atop the plywood when plywood flooring is used. Headers shall be placed a distance back from the skid ends skids equal to the end sheathing thickness. The header ends shall be notched for bases floored with lumber; header ends for plywood floored bases shall be set back from the outside edges of the outer skids (see Figs. 9 and 10). The notched and set back distances shall be equal to the thickness of the skids lower frame members.

(4) *Forklift Members*—The forklift members shall consist of the header and two equal size members, spaced 20 and 40 in. [508 and 1016 mm] (on center) from each skid end and bolted as shown in Fig. 7. Where the form of the item to be crated makes it

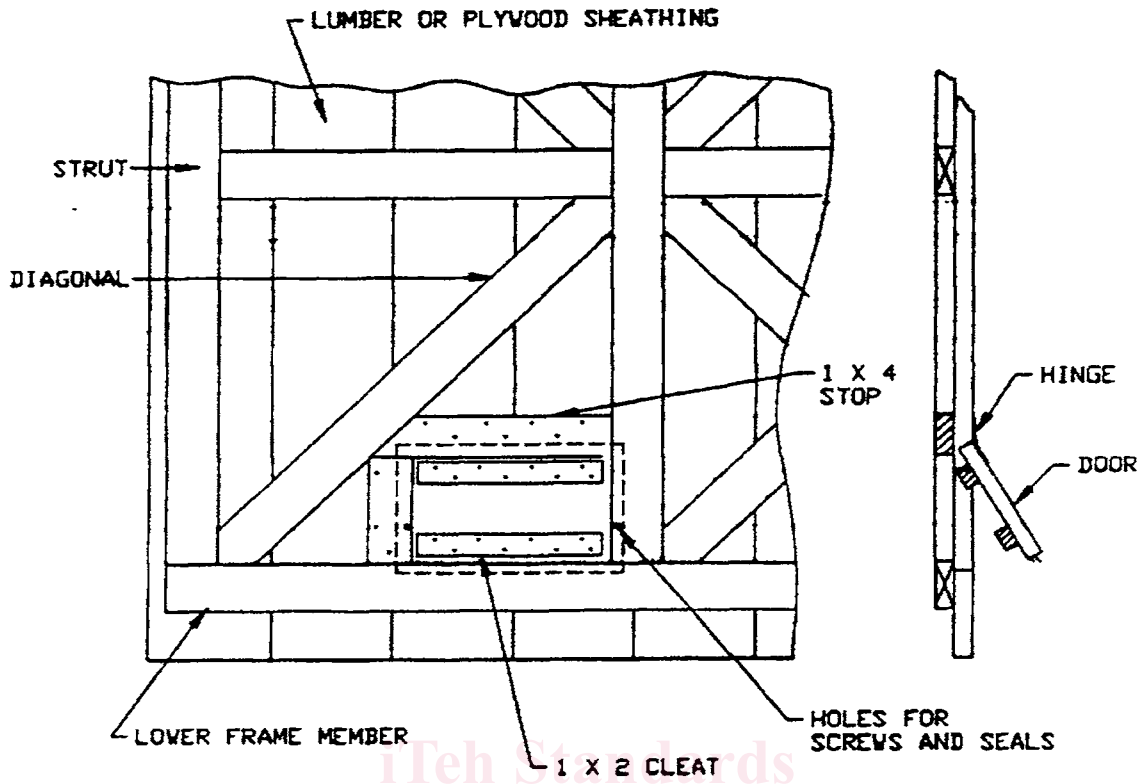

NOTE—All dimensions in inches.
FIG. 5 Inspection Door (Inside View)

TABLE 2 Ventilation Hole Requirements^A

Crate Volume ft ³ [m ³]	Lumber-Sheathed Crates End Ventilation ^B	Perimeter Ventilation ^C	Plywood-Sheathed Crates Area Required in Each End ^D in. ² [mm ²]
0-100 [0-2.8]	3	6	7 [4516]
100-150 [2.8-4.3]	4	8	10 [6451]
150-200 [4.3-5.7]	5	10	14 [9032]
200-400 [5.7-11.3]	9	18	27 [17 429]
400-600 [11.3-17]	14	27	40 [25 806]
600-800 [17-22.7]	18	36	52 [33 548]
800-1000 [22.7-28.3]	22	44	66 [42 581]
1000-1200 [28.3-34]	27	54	80 [51 613]
1200 and over [34 and over]	33	66	100 [64 516]

^A In large crates, where a large ventilating area is required, two or more slots or clusters of holes may be used in each panel.

^B Minimum number of 3/4 in. [19 mm] diameter holes required in each end (place in cluster and use baffle).

^C As an alternative, total minimum number of 3/4 in. [19 mm] diameter holes required around perimeter (space evenly and slope to drain out).

^D Use baffle and screen.

impractical to use these members, or when crates are short or narrow, 2-in. [38-mm] thick lumber shall be used in the 48-in. [1219-mm] end areas as shown in Fig. 8. When 2-in. [38-mm] lumber is used in the forklift area and intermediate skids are required because of the base width, the 2-in. [38-mm] forklift members shall be bolted to the intermediate skids. Forklift members shall be bolted to the intermediate skids. Forklift members shall be notched or set back as specified for headers in 8.7.1.1(3). If loaded

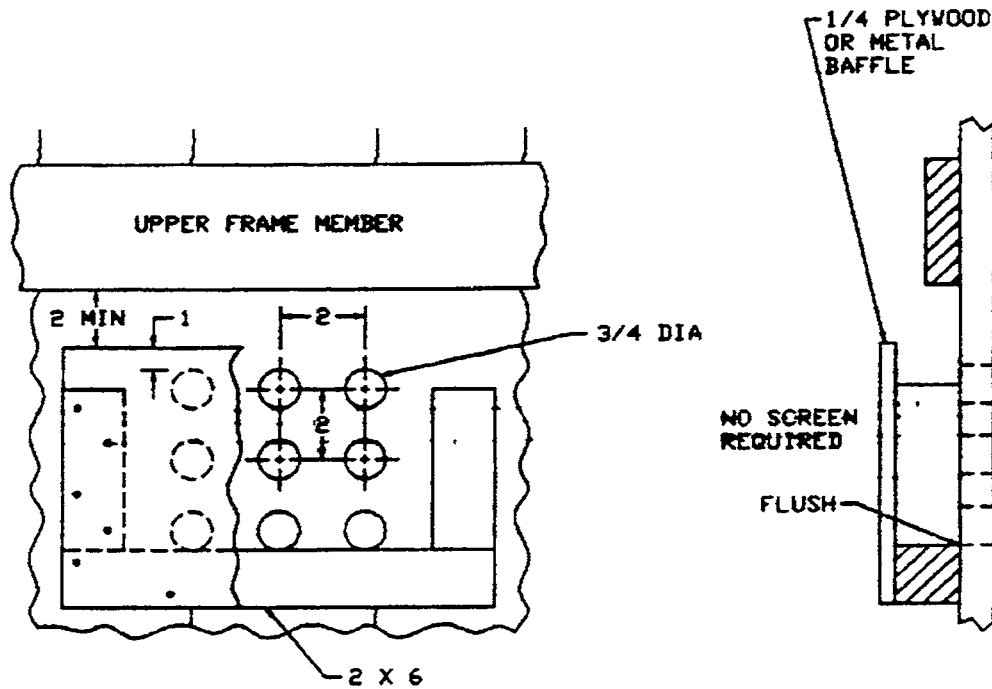

LUMBER SHEATHED CRATE

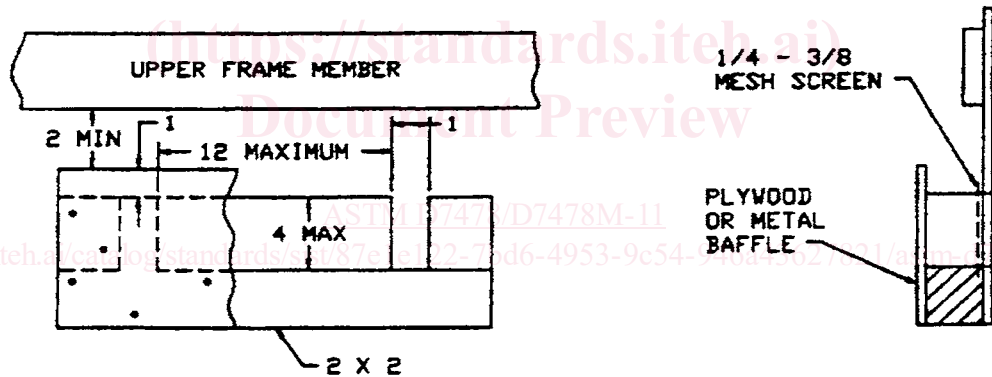

PLYWOOD SHEATHED CRATE

NOTE—All dimensions in inches.
 FIG. 6 Crate Ventilation (Inside View)

containers center of balance is other than the center of the base, the space for forklift entry shall be positioned so that the center of balance is centered in between forklift openings.

(5) *Load-bearing Floorboards*—Load-bearing floorboards shall be placed where the concentrated loads of the contents occur. The cross section shall be determined from Table 10. The forklift members and any 1 or 2-in. [19 or 38-mm] flooring may be considered as load bearing within limits of their assigned values. The load-bearing floor boards ends shall be notched or set back from the base edge in the same manner as described for headers as specified in 8.7.1.1(3) (see Figs. 7 and 8). Load-bearing floorboards 4 in. [89 mm] wide shall be bolted to each skid with one carriage bolt, and load-bearing floorboards over 4 in. [89 mm] wide shall be bolted to each skid with two carriage bolts, and the intermediate skid where one is required. Bolt diameters shall be the same as specified in 8.7.1.1(3) for corresponding skid sizes.

(6) *Lumber Flooring*—Lumber floorboards shall be neither less than 1 in. [19 mm] thick nor less than 4 in. [89 mm] wide, and shall be placed at right angles to the skids. Boards shall be spaced 1/4 in. [6 mm] apart for drainage and the leadboards flushed with the skids' outside face. When a large area of the base is floored with 2-in. [38-mm] thick lumber, the use of filler strips 2 in. [38 mm] wide shall be used along each side over the thinner flooring to equal the thickness of the 2-in. [38-mm] flooring as shown in Fig. 8. The filler strips shall be nailed to the flooring with two staggered rows of nails spaced 10 in. [254 mm] apart. Nailing

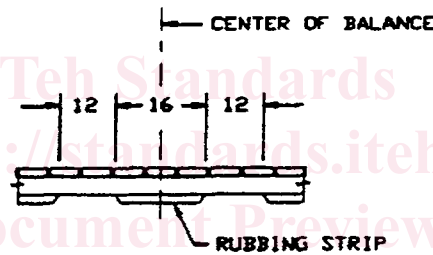
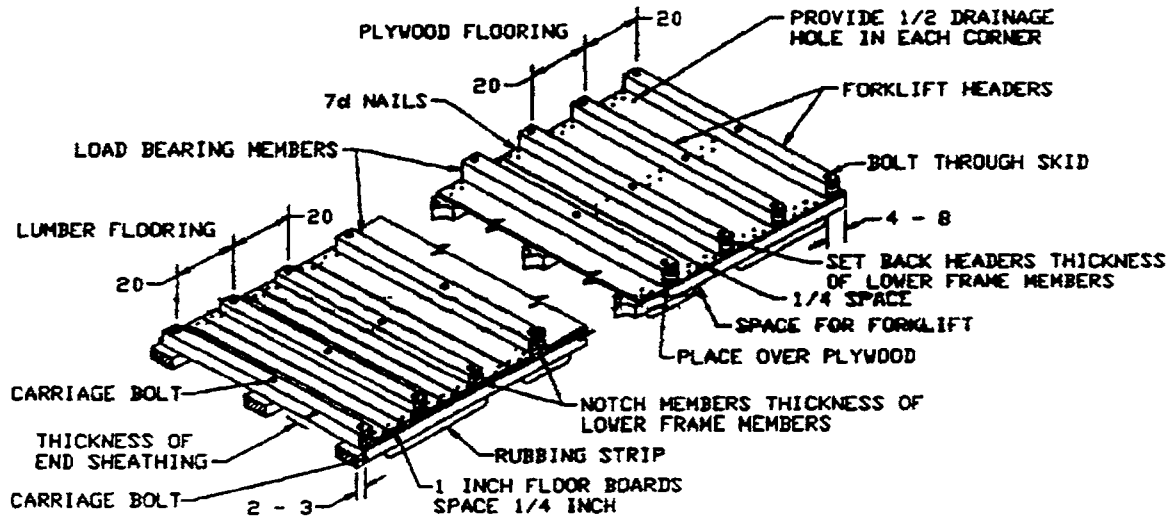

FORKLIFT AREA

ASTM D7478/D7478M-11

NOTE—All dimensions in inches.

FIG. 7 Details of Skid-Type Base (With Forklift Headers)

of floorboards to skids shall be as shown on Fig. 1 and as specified in 8.1.

(7) *Plywood Flooring*—Plywood $\frac{3}{8}$ in. [10 mm] thick, may be used in place of 1-in. [19-mm] lumber flooring as shown in Figs. 7 and 8, but not as load-bearing floorboards. Plywood flooring shall be laid flush with the skids' outer edges and with the face grain perpendicular to the skid length. Headers and load-bearing floorboards shall be placed on top of the plywood and bolted to the skids after the plywood has been nailed in place. Plywood flooring shall be nailed to each skid with two staggered rows of nails, staggered and spaced 6 in. [152 mm] apart in each row. Spacing, $\frac{1}{4}$ in. [6 mm], shall be allowed between plywood sheets for drainage. When $\frac{1}{3}$ to $\frac{1}{2}$ the area of the base is floored with 2-in. [38 mm] boards, the plywood flooring shall be used only between these areas. Filler strips shall be nailed over the plywood as shown in Fig. 8, with nailing as specified in 8.1.

(8) *Drainage*—A drainage hole, $\frac{1}{2}$ in. [13 mm] diameter, shall be drilled adjacent to each header or load-bearing member in each outer edge of each base plywood floored section (a "section" being a portion of the base in which water might be trapped) (Figs. 7 and 8). Care shall be taken to locate the holes so that the holes will not be covered when the contents are placed on the crate base.

8.7.1.2 *Style B (Sill-Type)*—Style B bases shall be constructed as shown in Fig. 9. The load contained on Style B bases shall always be transmitted to the side sills by means of intermediate sills or by the article itself.

(1) *Side and End Sills*—The side sill size shall be determined from Table 11. End sills shall be the same size as side sills. The side sills shall overlap the end sills as shown in Fig. 9. Sills shall be laminated as shown in Fig. 4, when necessary.

(2) *Intermediate Sills and Load-Bearing Headers*—Intermediate sills shall be applied crosswise of the base. The intermediate sill size shall be determined from Table 12. The weight used to determine the size of an intermediate sill shall be that amount of the load actually supported by that sill. Load-bearing headers shall be the same size as intermediate sills. Load-bearing headers and intermediate sills will not be required when the side sills support the entire load. Load-bearing headers shall be attached at their ends to intermediate sills and intermediate sills shall be attached at their ends to side sills by a combination of nailing and the use of metal strap hangers fabricated from $1\frac{1}{4} \times 0.035$ in. [32 × 0.89 mm] nail-on strapping as shown in Fig. 10.

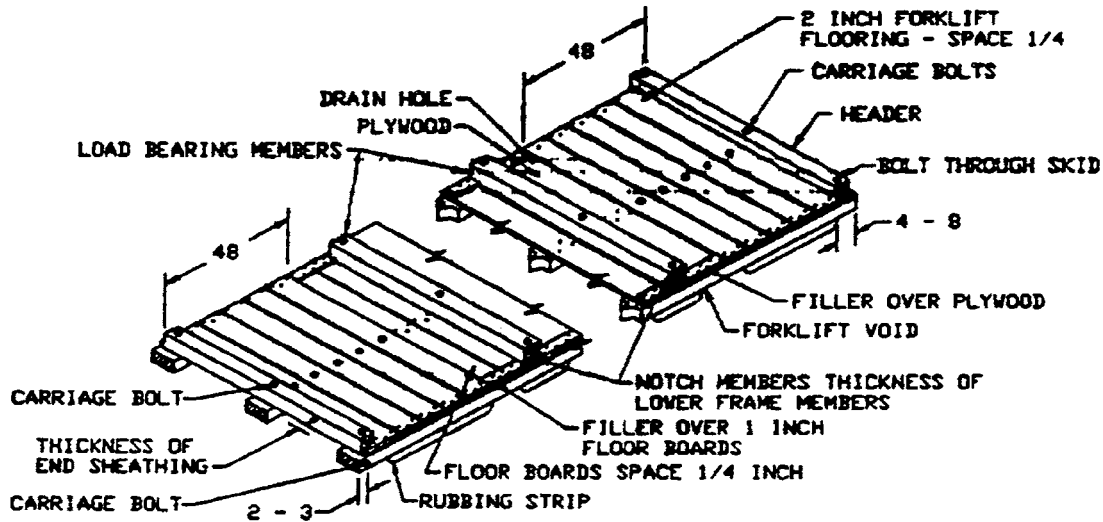

LUMBER FLOORING

PLYWOOD FLOORING

NOTE—All dimensions in inches.

FIG. 8 Details of Skid-Type Base (With 2-in. Forklift Flooring)

TABLE 3 Allowable Minimum Skid Sizes

Maximum Net Load		Crate Maximum Length		Skids Nominal Size	
lb	kg	ft	mm	in.	mm
300	[136] ^A	16	[4877]	2 × 4 (flat)	38 × 89 (flat) ^A
1000	[454]	12	[6858]	2 × 4 (flat)	38 × 89 (flat) ^A
2000	[907]	20	[6096]	3 × 3 or	64 × 64 or
				3 × 4 (flat)	64 × 89 (flat) ^B
10000	[4535]	32	[9754]	4 × 4	89 × 89
30000	[13608]	20	[6096]	4 × 6	89 × 140
				(on edge)	(on edge)

^A For nailed crates only.

^B For crates with 2-in. [38-mm] thick lower frame member or 2-in. [38-mm] end struts.

TABLE 4 Required Header Sizes and Carriage Bolt Sizes

Skid Size		Header Size		Bolt Diameter	
in.	[mm]	in.	[mm]	in.	[mm]
2 × 4	[38 × 89]	2 × 4 ^A	[38 × 89]	3/8	10
3 × 3	[64 × 64]	3 × 3	[64 × 64]	3/8	10
3 × 4	[64 × 89]				
4 × 4	[89 × 89]	4 × 4	[89 × 89]	1/2	12
4 × 6	[89 × 140]				

^A For nailed crates only in width to 48 in. [1219 mm]. For wider crates or bolted crates, use 3 × 3 in. [64 × 64 mm].

(3) *Bridging*—Intermediate sills shall be bridged at the ends with 1-in. [19-mm] lumber and at intervals along the span not exceeding 4 ft [1219 mm] with 2-in. [38-mm] lumber the same depth as the intermediate sills (see Fig. 9).

(4) *Bottom Sheathing*—Style B bases shall be sheathed on the bottom with lumber securely nailed to the sills bottom surface at right angles to the direction of the side sills. Boards shall be 4 to 10 in. [89 to 235 mm] wide and not less than 1-in. [19-mm] material for spans less than 30 in. [762 mm] between longitudinal members and not less than 2-in. [38-mm] material for spans of 30 in. [762 mm] or more. Bottom sheathing shall be flush with the outside face of all side and end sills and be spaced 1/4 in. [6 mm] apart for drainage. Nailing pattern as shown in Fig. 1 shall be followed.

(5) *Rubbing Strips*—Style B bases shall have 3-in. [64-mm] thick rubbing strips, not less than 4 in. [89 mm] wide. The rubbing strips shall always be applied lengthwise of the base and positioned under each longitudinal member. When required, intermediate rubbing strips of the same sizes are located so that the clear distance between rubbing strips does not exceed 36 in. [914 mm]. Other requirements shall be as specified in 8.7.1.1(2).

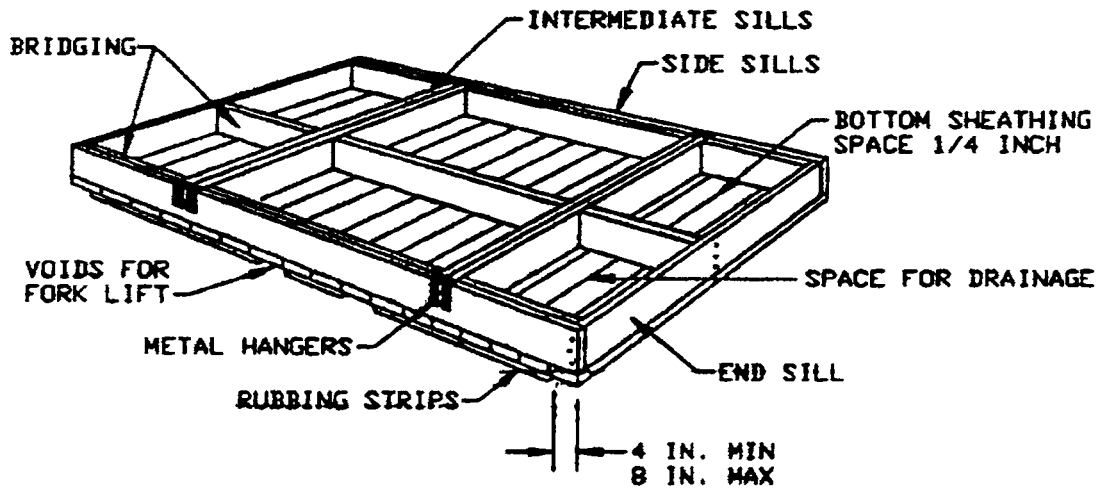

SILL BASE WITH DOUBLED SILLS

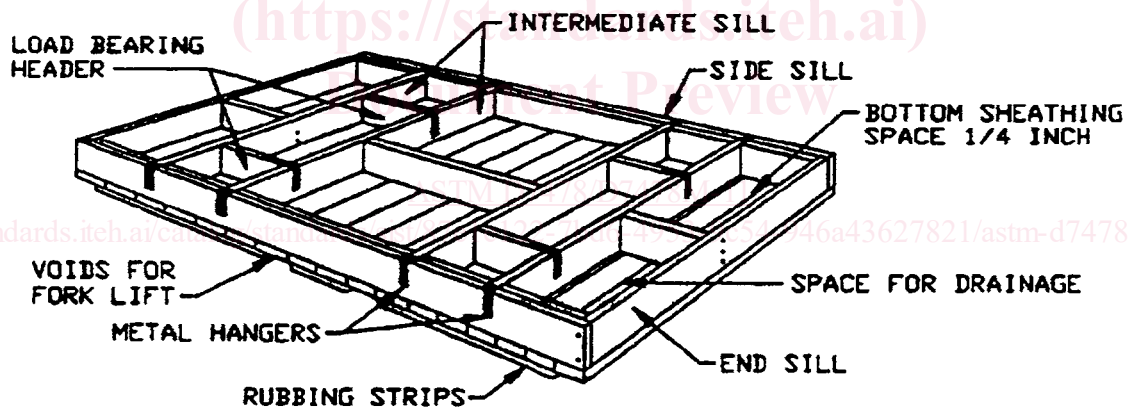

SILL BASE WITH LOAD-BEARING HEADERS

FIG. 9 Sill-Type Bases

8.7.2 *Tops*—Tops shall be double sheathed and shall be (a) narrow, widths through 54 in. [1372 mm]; (b) intermediate, widths over 54 through 60 in. [1372 through 1524 mm]; (c) wide, over 60 through 120 in. [1524 through 3048 mm] in width. Plywood sheathing $\frac{1}{4}$ in. [6 mm] thick, shall be attached to the lumber framing with its face grain parallel with the top width and its edges flush with the framing outside edges. All plywood sheathing joints shall be made over joists or other frame members. Roofing felt, or polyethylene film not less than 4 mils thick, shall be applied over the plywood with a minimum 4-in. [102-mm] overlap at joints. A non-hardening caulk or mastic shall be applied in the overlap area. Top sheathing boards not less than 4 in. [89 mm] wide shall be placed over the plywood sheathing and waterproof barrier and shall extend beyond the top framing outer edges by an amount equal to the thickness of side and end panel sheathing less $\frac{1}{8}$ in. [3 mm]. Headers joining the joists together shall be 1 in. [19 mm] thick by the joist depth for intermediate and wide tops For tops not exceeding 96 in. [2438 mm] wide, $\frac{1}{2}$ -in. [13-mm] thick plywood single sheathing may be used in lieu of the double sheathed top. Plywood face grain shall be parallel with the top width. When joists do not coincide with plywood joints, a 1 × 4-in. [16 × 89-mm] lumber joint cover shall be used on the inside of the top. Prior to securing the plywood to the joists or joint covers, a non-hardening caulking shall be applied at three places at each joint—between the plywood panels at their butt joint, and between the plywood and joint cover or joist on either side of the butt