



Designation: E 1165 – 92 (Reapproved 2002)

Standard Test Method for Measurement of Focal Spots of Industrial X-Ray Tubes by Pinhole Imaging¹

This standard is issued under the fixed designation E 1165; the number immediately following the designation indicates the year of original adoption or, in the case of revision, the year of last revision. A number in parentheses indicates the year of last reapproval. A superscript epsilon (ϵ) indicates an editorial change since the last revision or reapproval.

1. Scope

1.1 This test method provides instructions for determining the length and width dimensions of line focal spots in industrial X-ray tubes (see Note 1). This determination is based on the measurement of an image of a focal spot that has been radiographically recorded with a “pinhole” projection/imaging technique.

NOTE 1—Line focal spots are associated with vacuum X-ray tubes whose maximum voltage rating does not generally exceed 500 kV.

1.2 This test method may not yield meaningful results on focal spots whose nominal size is less than 0.3 mm (0.011 in.). (See Note 2.)

NOTE 2—The X-ray tube manufacturer may be contacted for nominal focal spot dimensions.

1.3 This test method may also be used to determine the presence or extent of focal spot damage or deterioration that may have occurred due to tube age, tube overloading, and the like. This would entail the production of a focal spot radiograph (with the pinhole method) and an evaluation of the resultant image for pitting, cracking, and the like.

1.4 Values stated in SI units are to be regarded as the standard. Inch-pound units are provided for information only.

1.5 *This standard does not purport to address all of the safety concerns, if any, associated with its use. It is the responsibility of the user of this standard to establish appropriate safety and health practices and determine the applicability of regulatory limitations prior to use.*

2. Referenced Documents

2.1 ASTM Standards:

E 999 Guide for Controlling the Quality of Industrial Radiographic Film Processing²

3. Terminology

3.1 Definitions of Terms Specific to This Standard:

¹ This test method is under the jurisdiction of ASTM Committee E07 on Nondestructive Testing and is the direct responsibility of Subcommittee E07.01 on Radiology (X and Gamma) Method.

Current edition approved May 15, 1992. Published July 1992. Originally published as E 1165 – 87. Last previous edition E 1165 – 87.

² *Annual Book of ASTM Standards*, Vol 03.03.

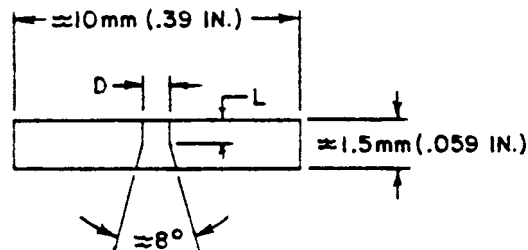

FIG. 1 Pinhole Diaphragm Design

3.1.1 *actual focal spot*—the X-ray producing area of the target as viewed from a position perpendicular to the target surface (see Fig. 2).

3.1.2 *effective focal spot*—the X-ray producing area of the target as viewed from a position perpendicular to the tube axis in the center of the X-ray beam (see Fig. 2).

3.1.3 *line focal spot*—a focal spot whose projected pinhole image consists primarily of two curved lines (see Fig. 3).

4. Significance and Use

4.1 One of the factors affecting the quality of a radiographic image is geometric unsharpness. The degree of geometric unsharpness is dependent upon the focal size of the radiation source, the distance between the source and the object to be radiographed, and the distance between the object to be radiographed and the film. This test method allows the user to determine the focal size of the X-ray source and to use this result to establish source to object and object to film distances appropriate for maintaining the desired degree of geometric unsharpness.

5. Apparatus

5.1 *Pinhole Diaphragm*—The pinhole diaphragm shall conform to the design and material requirements of Table 1 and Fig. 1.

5.2 *Camera*—The pinhole camera assembly consists of the pinhole diaphragm, the shielding material to which it is affixed, and any mechanism that is used to hold the shield/diaphragm in position (jigs, fixtures, brackets, and the like; see Fig. 4).

5.3 *Film*—Industrial type extra fine grain. No intensifying screens are to be used. The film shall be processed in accordance with Guide E 999.

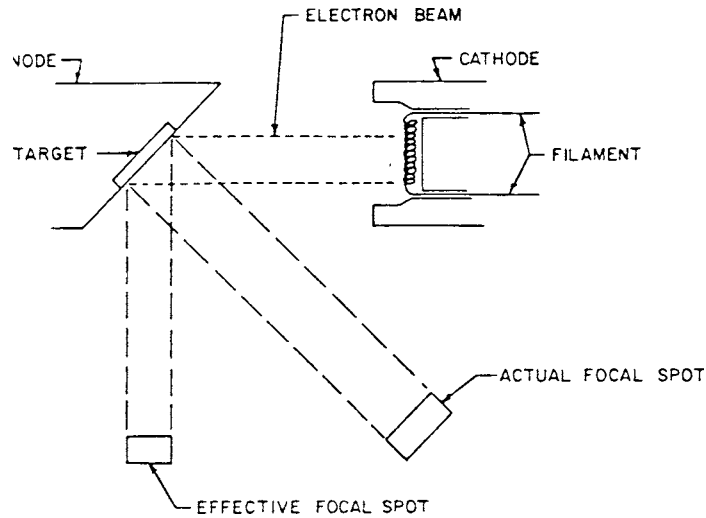

FIG. 2 Actual/Effective Focal Spot

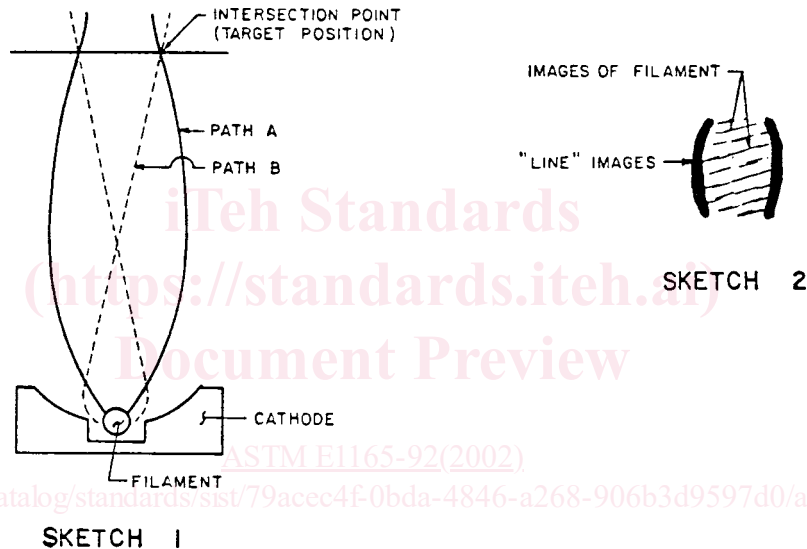

FIG. 3 Line Focal Spot

NOTE 1—During the production of X-rays the electrons are accelerated from the filament to the target in two separate paths (see Sketch 1). Electrons emitted at the front of the filament travel primarily along Path A, and electrons emitted at the backside of the filament travel primarily along Path B. Note that these two paths intersect at a certain point; this is the point at which the target is positioned. As a result, the pinhole picture of the focal spot shows two lines that correspond with the intersections of Paths A and B at the target (see Sketch 2).

5.4 *Image Measurement Apparatus*—This apparatus is used to measure the size of the image of the focal spot. The apparatus shall be an optical comparator with built-in graticule with 0.1 mm or .001 in., or both divisions and magnification of 5X to 10X (or equivalent).

6. Procedure

6.1 If possible, use a standard 91.44 cm (36 in.) focal spot to film plane distance (FFD) for all exposures. If machine geometry or accessibility limitations will not permit the use of a 91.44 cm (36 in.) FFD, use the maximum attainable FFD (in these instances adjust the relative distances between focal spot, pinhole, and film accordingly to suit the image enlargement factors specified in Table 2). The distance between the focal spot and the pinhole is based on the nominal size of the focal

spot being measured and the desired degree of image enlargement (see Fig. 5). The specified focal spot to pinhole distance (FHD) for the different nominal focal spot size ranges is provided in Table 2. Position the pinhole such that it is within $\pm 1^\circ$ of the central axis of the X-ray beam. Fig. 6 illustrates a typical focal spot exposure arrangement.

NOTE 3—The accuracy of the pinhole system is highly dependent upon the relative distances between (and alignment of) the focal spot, the pinhole, and the film. Accordingly, specially designed apparatus may be necessary in order to assure compliance with the above requirements. Fig. 7 provides an example of a special collimator that can be used to ensure conformance with the $\pm 1^\circ$ alignment tolerance. Some other standards impose very stringent alignment requirements and express these requirements in terms of radial tolerances. These documents do not, however, address any means for assuring compliance with such tolerances. In order to simplify the focal spot radiography technique and to improve the

TABLE 1 Pinhole Diaphragm Design Requirements (Dimension)^A

NOTE 1—The pinhole diaphragm shall be made from one of the following materials:

- (1) An alloy of 90 % gold and 10 % platinum,
- (2) Tungsten,
- (3) Tungsten carbide,
- (4) Tungsten alloy,
- (5) Platinum and 10 % Iridium Alloy, or
- (6) Tantalum.

Nominal Dimension of Focal Spot, mm (in.) ^B	Nominal Diameter of Diaphragm Opening, mm (in.)	Required "D" and "L" Dimensions, mm (in.)	
		D	L
0.3 to 1.2 (0.011 to 0.046) incl	0.030 (0.0011)	0.030 ± 0.005 (0.0011 ± 0.0002)	0.075 ± 0.010 (0.0029 ± 0.0004)
>1.2 to 2.5 (0.046 to 0.097) incl	0.075 (0.0029)	0.075 ± 0.005 (0.0029 ± 0.0002)	0.350 ± 0.010 (0.014 ± 0.0004)
>2.5 (0.097)	0.100 (0.0039)	0.100 ± 0.005 (0.0039 ± 0.0002)	0.500 ± 0.010 (0.02 ± 0.0004)

^A See Fig. 1.

^B Nominal focal spot dimensions may be obtained from the X-ray tube manufacturer.

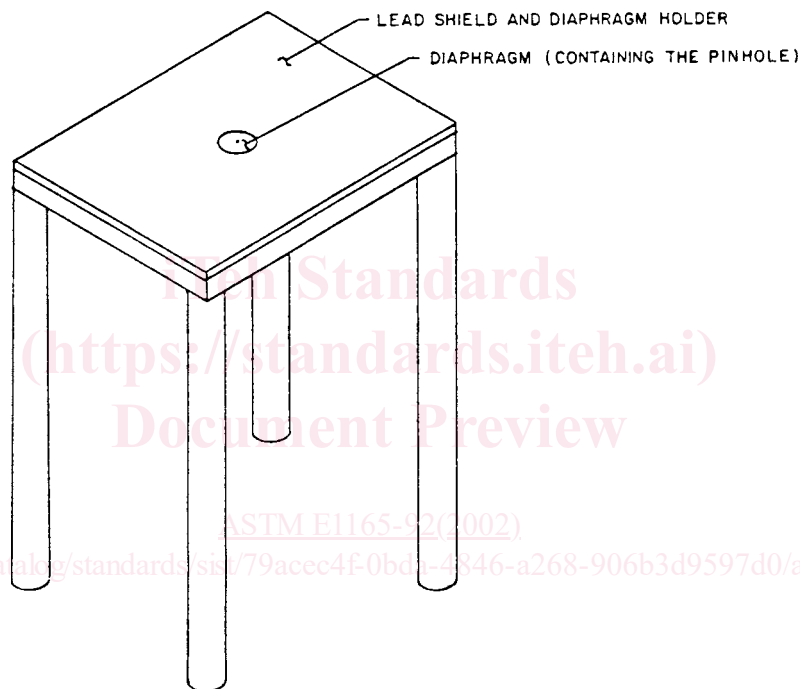

FIG. 4 Pinhole Camera (Typical)

TABLE 2 Image Enlargement Factors

Nominal Focal Spot Size, mm (in.)	Enlargement Factor	Distance Between Focal Spot and Pinhole (FHD), cm (in.) ^A
0.3 to 1.2 (0.011 to 0.046) incl	3×	22.9 (9)
>1.2 to 2.5 (0.046 to 0.097) incl	2×	30.5(12)
>2.5 (0.097)	1×	45.7(18)

^A When using a technique that entails the use of enlargement factors and a 91.44 cm (36 in.) focal spot to film distance (FFD) is not possible (see 6.1), the distance between the focal spot and the pinhole (FHD) shall be adjusted to suit the actual focal spot to film distance (FFD) used (for example, if a 61 cm (24 in.) FFD is used, the FHD shall be 15.25 cm (6 in.) for 3× enlargement, 20.32 cm (8 in.) for 2× enlargement, and the like).

overall practicality of the procedure, it is considered that a workable alignment tolerance, and a means of assuring conformance with that tolerance, is appropriate. Accordingly, this standard addresses tolerances in angular terms and provides a method for assuring compliance with

these tolerances. This provides a practical means of meeting the precision and bias requirements of Section 9.

6.2 Position the film as illustrated in Fig. 6. The exposure identification appearing on the film (by radiographic imaging) should be X-ray machine identity (that is, make and serial number), organization making the radiograph, and date of exposure.

6.3 Adjust the kilovoltage and milliamperage settings on the X-ray machine to that specified in Table 3.

6.4 Expose the film such that the density of the darkest portion of the focal spot image conforms to the limits specified in Table 4. Density measurement shall be as illustrated in Fig. 8. Density shall be controlled by exposure time only.

6.5 Process the film in accordance with Guide E 999.

6.6 Focal Spot Measurement:

6.6.1 Back Lighting—Back lighting shall be such that the focal spot image can be easily and comfortably viewed.