



Designation: ~~D6862-04~~ Designation: D6862 - 11

Standard Test Method for 90 Degree Peel Resistance of Adhesives¹

This standard is issued under the fixed designation D6862; the number immediately following the designation indicates the year of original adoption or, in the case of revision, the year of last revision. A number in parentheses indicates the year of last reappraisal. A superscript epsilon (ϵ) indicates an editorial change since the last revision or reappraisal.

INTRODUCTION

The purpose of this test method is to provide for the determination of the resistance-to-peel strength of adhesives when surfaces joined by an adhesive are separated by applying a force to one of the surfaces at a 90 degree angle. The accuracy of the results of strength tests of adhesive bonds will depend on the conditions under which the bonding process is carried out. Unless otherwise agreed upon between the manufacturer and the purchaser, the bonding conditions shall be prescribed by the manufacturer of the adhesive. In order to ensure that complete information is available to the individual conducting the tests, the manufacturer of the adhesive shall furnish numerical values and other specific information for each of the following variables:

(1) Procedure for preparation of the surfaces prior to application of the adhesive, the cleaning and drying of surfaces, and special surface treatments, which are not specifically limited by the pertinent test method.

(2) Complete mixing directions for the adhesive.

(3) Conditions for the application of the adhesive, including the rate of spread or thickness of the film, number of coats to be applied, whether to one or both of the surfaces, and the conditions of drying.

(4) Assembly conditions before the application of pressure, including room temperature and length of time.

(5) Curing conditions, including the amount of pressure to be applied, the length of time under pressure, and the temperature of the assembly when under pressure. It should be stated whether this temperature is that of the glue line or of the atmosphere at which the assembly is to be maintained.

(6) Conditioning procedure before testing, unless a standard procedure is specified, including length of time and relative humidity.

Range may be prescribed for any variable provided it is acceptable to both the manufacturer and the purchaser of the adhesive.

1. Scope*

1.1 This test method covers the determination of the resistance-to-peel strength of an adhesive bond between one rigid adherend and one flexible adherend when tested at an angle of approximately 90 degrees under specified conditions of preparation and testing.

1.2 A variation in thickness of the adherends will generally influence test values. For this reason, the thickness of the adherends used to make the test specimens shall be specified in the material specification. When no thickness is specified, the flexible adherend shall be $0.630\text{--}0.60$ mm (0.025 in.) thick and the rigid adherend shall be $1.631\text{--}1.60$ mm ($0.064\text{--}0.060$ in.) thick.

NOTE 1—A heavy fabric, such as canvas, has been used as a flexible adherend.

1.3 The values stated in SI units are to be regarded as the standard. The values given in parentheses are for information only.

1.4 *This standard does not purport to address all of the safety concerns, if any, associated with its use. It is the responsibility of the user of this standard to establish appropriate safety and health practices and determine the applicability of regulatory limitations prior to use.*

¹ This test method is under the jurisdiction of ASTM Committee D14 on Adhesives and is the direct responsibility of Subcommittee D14.10 on Working Properties. Current edition approved June Dec. 1, 2004:2011. Published June 2004:January 2012. Originally approved in 2003. Last previous edition approved in 2003:2004 as D6862 - 034. DOI: ~~10.1520/D6862-04~~ 10.1520/D6862-11.

*A Summary of Changes section appears at the end of this standard.

2. Referenced Documents

- 2.1 *ASTM Standards*:²
 D907 Terminology of Adhesives
 E4 Practices for Force Verification of Testing Machines
 E177 Practice for Use of the Terms Precision and Bias in ASTM Test Methods

3. Terminology

3.1 *Definitions*—Many of the definitions used in this test method are defined in Terminology D907.

4. Summary of Test Method

4.1 This test method consists of testing laminated or bonded adherends, where one adherend is rigid and the other adherend is flexible, by peeling of the flexible adherend from the rigid adherend at a 90 degree angle of peel using the test fixture shown in Fig. 1 or an equivalent fixture that will perform the same function.

5. Significance and Use

5.1 This test method is useful for acceptance and quality control testing. Adherends, application procedure, and sample conditioning shall be as agreed upon by the manufacturer and the user of the adherends and the adhesive.

6. Apparatus

6.1 *Testing Machine*—The testing machine shall have a load weighing system conforming to the requirements of Practice E4. It shall have the capability of constant Rate of Extension (CRE) with a crosshead speed range of ± 2.512 mm/min (0.5 in./min) to

² For referenced ASTM standards, visit the ASTM website, www.astm.org, or contact ASTM Customer Service at service@astm.org. For *Annual Book of ASTM Standards* volume information, refer to the standard’s Document Summary page on the ASTM website.

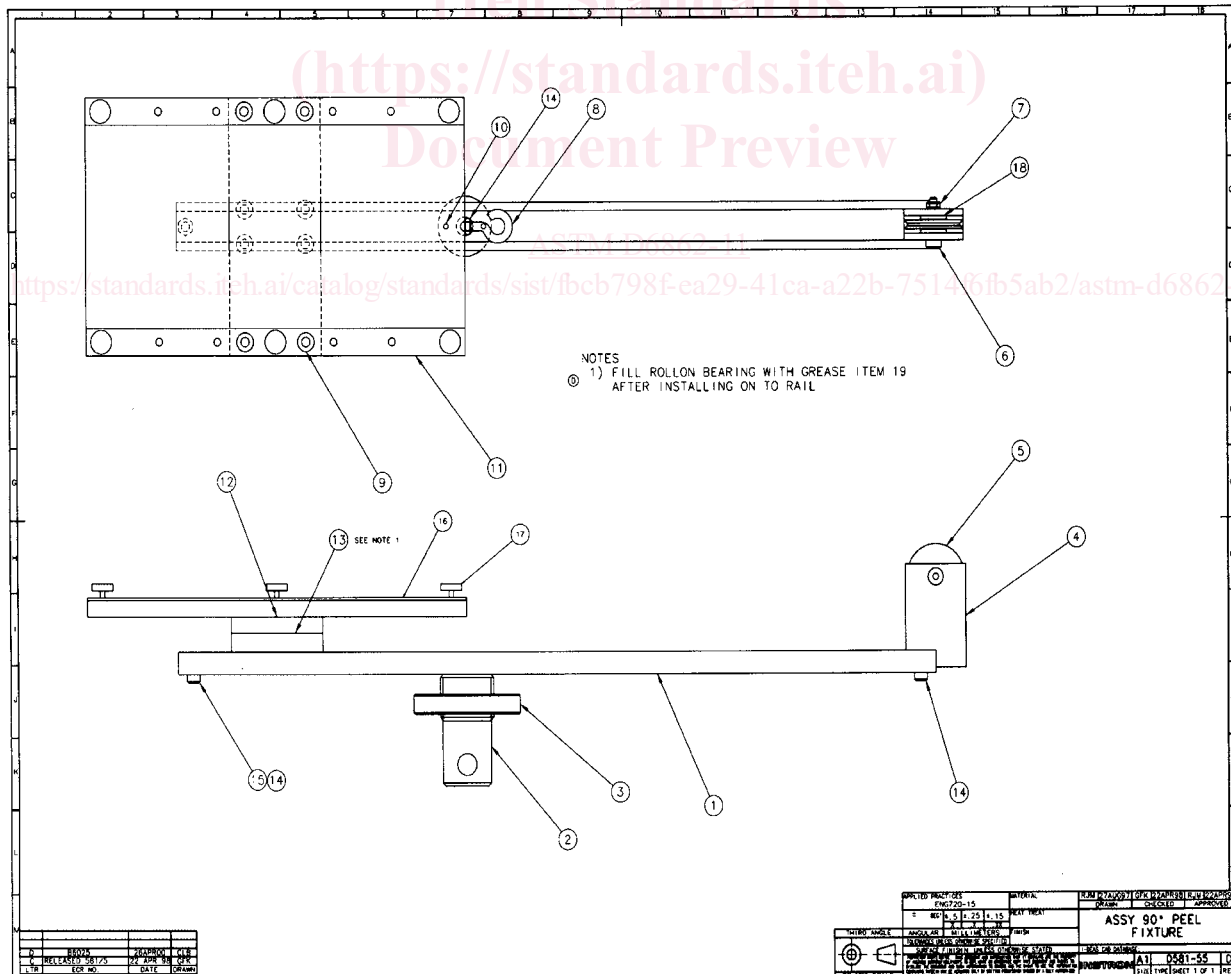

FIG. 1 Sample Test Apparatus

254250 mm/min (10 in./min). The testing machine shall have an adequate pen or computer response to record the force-extension curve. Self-aligning grips shall be used to hold the flexible adherent. The breaking load shall fall between 15 and 85 % of the full scale load range. The grips need to engage the outer 25.425 mm (1 in.) of the flexible adherent firmly and, when load is applied, the direction of the applied force needs to be through the center line of the grip assembly.

6.2 *Test Fixture*—The test fixture will consist of a platform that is smoothly driven horizontally at the same speed as the crosshead moves vertically, so that a 90 degree angle is maintained between the flexible adherent and the fixed adherent. The platform shall have means for clamping the fixed adherent to the surface. See Fig. 2 and Fig. 3

7. Sample Preparation

7.1 Laminated test panels (see Fig. 4) consist of two adherends properly prepared and bonded together in accordance with the adhesive manufacturer’s recommendations or as required by a product performance specification.

7.2 Bend the unbonded end of the flexible adherend perpendicular to the rigid adherend for clamping in the grip of the testing machine. Test four specimens per aging condition. Typical sample aging conditions call for testing of panels at 4 h, 24 h, 7 days, and 14 days after assembly.

NOTE 2—Direct comparison of different adhesives may be made only when specimen construction and test conditions are identical.

NOTE 3—A specimen width agreed upon by the manufacturer and user may be used, provided the test machine grip and peel test fixtures are of ample width to apply load uniformly across the width of the adherends.

8. Test Method

8.1 Insert the test specimen into the peel test fixture as shown in Fig. 3, with the unbonded end of the flexible adherend gripped

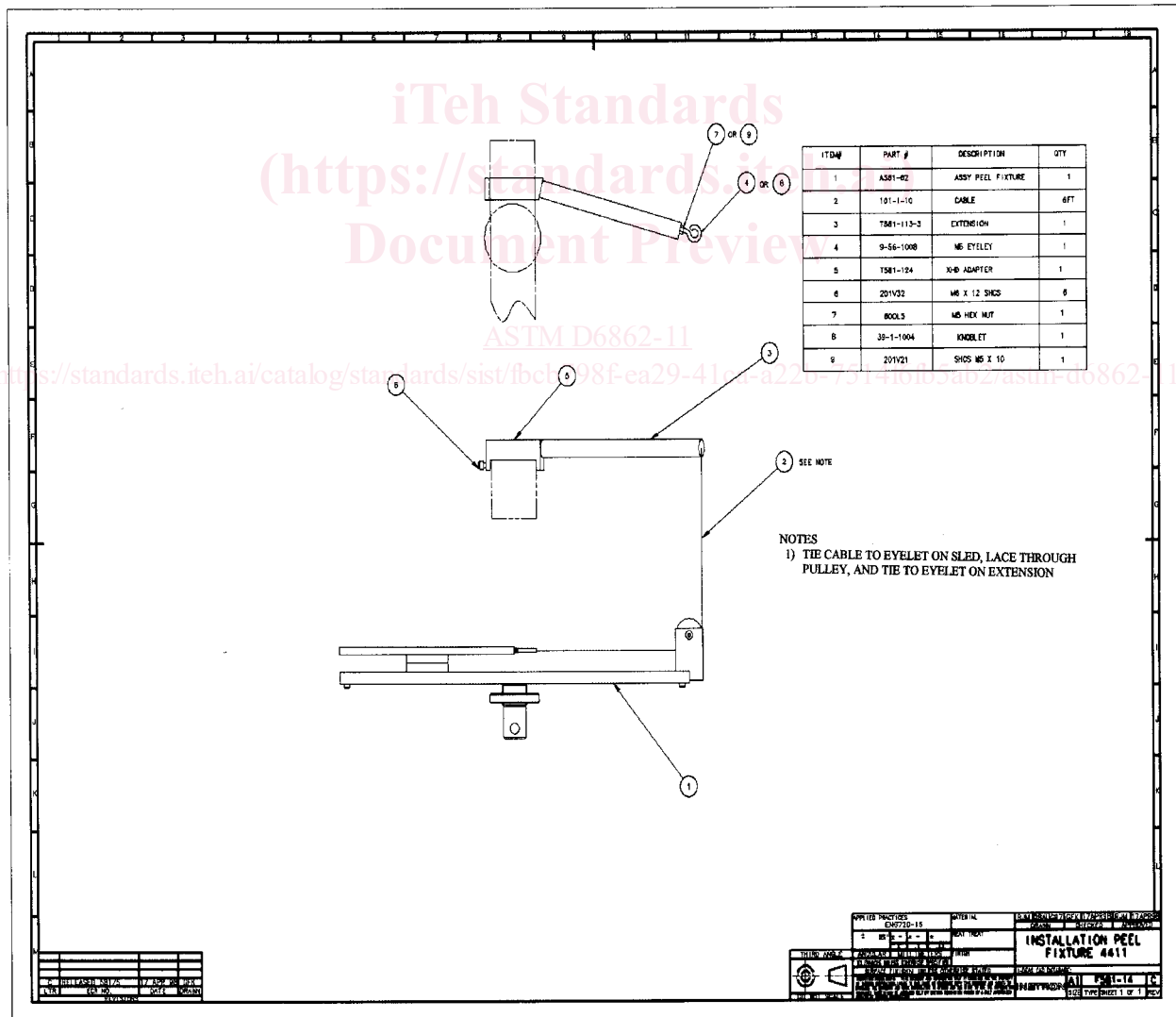

FIG. 2 Assembled Sample Test Apparatus