



Designation: E839-05 ~~Designation: E839 - 11~~

Standard Test Methods for Sheathed Thermocouples and Sheathed Thermocouple Material Cable¹

This standard is issued under the fixed designation E839; the number immediately following the designation indicates the year of original adoption or, in the case of revision, the year of last revision. A number in parentheses indicates the year of last reapproval. A superscript epsilon (ϵ) indicates an editorial change since the last revision or reapproval.

INTRODUCTION

Thermocouples are widely used in industry and they provide reliable service. However, if thermocouples fail in service, the consequences can range from negligible to life threatening. Often a loss of equipment, product, or operating time will result. The user should weigh the potential consequences of thermocouple failure when considering what tests should be performed. No tests are required by this document except those specifically ordered by the user. This document lists methods for testing sheathed thermocouples and thermocouple material but does not state criteria for acceptance. The acceptance criteria for the particular thermocouple, when subjected to the tests, are given in other ASTM standard specifications for that thermocouple. Examples from ASTM thermocouple specifications for acceptance criteria are given for many of the tests. These tabulated values are *not* necessarily those that would be required to meet these tests, but are given here as examples only.

Users should be aware that certain characteristics of thermocouple materials, including the emf versus temperature relationship may change with time in use; consequently, test results and performance obtained at time of manufacture may not necessarily apply throughout an extended period of use. It should be further noted that due to possible changes in homogeneity, attempting to recalibrate used thermocouples is likely to yield irrelevant results, and is not recommended.

1. Scope

1.1 These are test methods for sheathed thermocouple material and assemblies.

1.2 The tests are intended to ensure quality control and to evaluate the suitability of sheathed thermocouple material or assemblies for specific applications. Some alternative test methods to obtain the same information are given, since in a given situation an alternative test method may be more practical. Service conditions are widely variable and so it is unlikely that all the tests described will be appropriate for a given thermocouple application. A brief statement is made following each test description to indicate when it might be used.

1.1 This document lists methods for testing Mineral-Insulated, Metal-Sheathed (MIMS) thermocouple assemblies and thermocouple cable, but does not require that any of these tests be performed nor does it state criteria for acceptance. The acceptance criteria are given in other ASTM standard specifications that impose this testing for those thermocouples and cable. Examples from ASTM thermocouple specifications for acceptance criteria are given for many of the tests. These tabulated values are not necessarily those that would be required to meet these tests, but are included as examples only.

1.2 These tests are intended to support quality control and to evaluate the suitability of sheathed thermocouple cable or assemblies for specific applications. Some alternative test methods to obtain the same information are given, since in a given situation, an alternative test method may be more practical. Service conditions are widely variable, so it is unlikely that all the tests described will be appropriate for a given thermocouple application. A brief statement is made following each test description to indicate when it might be used.

1.3 The tests described herein include test methods to measure the following properties of sheathed thermocouple material and assemblies.

¹ These test methods are under the jurisdiction of ASTM Committee E20 on Temperature Measurement and is the direct responsibility of Subcommittee E20.04 on Thermocouples.

Current edition approved Nov. 1, 2005. Published December 2005. Originally approved in 1989. Last previous edition approved in 1996 as E839-96 which was withdrawn in August 2005 and reinstated in November 2005. DOI: 10.1520/E0839-05.

Current edition approved Nov. 1, 2011. Published January 2012. Originally approved in 1989. Last previous edition approved in 2005 as E839-05. DOI: 10.1520/E0839-11.

1.3.1 *Insulation Properties:*

~~1.3.1.1~~ *Compaction*—absorption method and tension method.

~~1.3.1.2~~ *Thickness.*

~~1.3.1.3~~ *Resistance*—room temperature and elevated temperature.

1.3.1.1 *Compaction*—direct method, absorption method, and tension method.

1.3.1.2 *Thickness.*

1.3.1.3 *Resistance*—at room temperature and at elevated temperature.

1.3.2 *Sheath Properties:*

~~1.3.2.1~~ *Integrity*—water test (two test methods) and mass spectrometer.

~~1.3.2.2~~ *Dimensions*—length, diameter, and roundness.

~~1.3.2.3~~ *Wall thickness.*

~~1.3.2.4~~ *Surface*—gross visual, finish, defect detection by dye penetrant, and cold-lap detection by tension test.

~~1.3.2.5~~ *Metallurgical structure.*

~~1.3.2.6~~ *Ductility*—bend test and tension test.

1.3.2.1 *Integrity*—two water test methods and mass spectrometer.

1.3.2.2 *Dimensions*—length, diameter, and roundness.

1.3.2.3 *Wall thickness.*

1.3.2.4 *Surface*—gross visual, finish, defect detection by dye penetrant, and cold-lap detection by tension test.

1.3.2.5 *Metallurgical structure.*

1.3.2.6 *Ductility*—bend test and tension test.

1.3.3 *Thermoelement Properties:*

~~1.3.3.1~~ *Calibration.*

~~1.3.3.2~~ *Homogeneity.*

~~1.3.3.3~~ *Drift.*

~~1.3.3.4~~ *Thermoelement diameter, roundness, and surface appearance.*

~~1.3.3.5~~ *Thermoelement spacing.*

~~1.3.3.6~~ *Thermoelement ductility.*

~~1.3.3.7~~ *Metallurgical structure.*

1.3.3.1 *Calibration.*

1.3.3.2 *Homogeneity.*

1.3.3.3 *Drift.*

1.3.3.4 *Thermoelement diameter, roundness, and surface appearance.*

1.3.3.5 *Thermoelement spacing.*

1.3.3.6 *Thermoelement ductility.*

1.3.3.7 *Metallurgical structure.*

1.3.4 *Thermocouple Assembly Properties:*

~~1.3.4.1~~ *Dimensions*—length, diameter, and roundness.

~~1.3.4.2~~ *Surface*—gross visual, finish, reference end seal, and defect detection by dye penetrant.

~~1.3.4.3~~ *Electrical*—continuity, loop resistance, and connector polarity.

~~1.3.4.4~~ *Radiographic inspection.*

~~1.3.4.5~~ *Thermoelement diameter.*

~~1.3.4.6~~ *Thermal response time.*

~~1.3.4.7~~ *Thermal cycle.*

1.3.4.1 *Dimensions*—length, diameter, and roundness.

1.3.4.2 *Surface*—gross visual, finish, reference junction end moisture seal, and defect detection by dye penetrant.

1.3.4.3 *Electrical*—continuity, loop resistance, and connector polarity.

1.3.4.4 *Radiographic inspection.*

1.3.4.5 *Thermoelement diameter.*

1.3.4.6 *Thermal response time.*

1.3.4.7 *Thermal cycle.*

1.4 The values stated in either SI units or inch-pound units are to be regarded separately as standard. The values stated in each system may not be exact equivalents; therefore, each system shall be used independently of the other. Combining values from the two systems may result in non-conformance with the standard.

1.5 This standard does not purport to address all of the safety concerns, if any, associated with its use. It is the responsibility of the user of this standard to establish appropriate safety and health practices and determine the applicability of regulatory limitations prior to use.

2. Referenced Documents

- 2.1 *ASTM Standards:*² ~~D2771 Test Methods for Compaction Density of Electrical Grade Magnesium Oxide~~
E3 [Guide for Preparation of Metallographic Specimens](#)
E94 [Guide for Radiographic Examination](#)
E112 [Test Methods for Determining Average Grain Size](#) ~~E142 Method for Controlling Quality of Radiographic Testing~~
E165 [Practice for Liquid Penetrant Examination for General Industry](#)
E177 [Practice for Use of the Terms Precision and Bias in ASTM Test Methods](#)
E207 [Test Method for Thermal EMF Test of Single Thermoelement Materials by Comparison with a Reference Thermoelement of Similar EMF-Temperature Properties](#)
E220 [Test Method for Calibration of Thermocouples By Comparison Techniques](#)
E230 [Specification and Temperature-Electromotive Force \(EMF\) Tables for Standardized Thermocouples](#)
E235 [Specification for Thermocouples, Sheathed, Type K and Type N, for Nuclear or for Other High-Reliability Applications](#)
E344 [Terminology Relating to Thermometry and Hydrometry](#)
E585/E585M [Specification for Compacted Mineral-Insulated, Metal-Sheathed, Base Metal Thermocouple Cable](#)
E608/E608M [Specification for Mineral-Insulated, Metal-Sheathed Base Metal Thermocouples](#)
E691 [Practice for Conducting an Interlaboratory Study to Determine the Precision of a Test Method](#)
E780 [Test Method for Measuring the Insulation Resistance of Mineral-Insulated, Metal-Sheathed Thermocouples and Thermocouple Cable at Room Temperature](#)
~~E988 Temperature-Electromotive Force (EMF) Tables for Tungsten-Rhenium Thermocouples~~ 1025 [Practice for Design, Manufacture, and Material Grouping Classification of Hole-Type Image Quality Indicators \(IQI\) Used for Radiology](#)
E1129/E1129M [Specification for Thermocouple Connectors](#)
E1350 [Guide for Testing Sheathed Thermocouples, Thermocouples Assemblies, and Connecting Wires Prior to, and After Installation or Service](#)
E1684 [Specification for Miniature Thermocouple Connectors](#)
E1751 [Guide for Temperature Electromotive Force \(EMF\) Tables for Non-Letter Designated Thermocouple Combinations](#)
E2181/E2181M
E2181/E2181M [Specification for Compacted Mineral-Insulated, Metal-Sheathed, Noble Metal Thermocouples and Thermocouple Cable](#)
2.2 *ANSI Standard*
B 46.1 [Surface Texture](#)³
2.3 *Other Standard*
USAEC Division of Reactor Development and Technology RDT Standard C 2-1T [Determination of Insulation Compaction in Ceramic Insulated Conductors August 1970](#)

3. Terminology

- 3.1 *Definitions*—The definitions given in Terminology E344 shall apply to these test methods.
3.2 *Definitions of Terms Specific to This Standard:*
3.2.1 *bulk cable, n*—~~a single length of thermocouple cable (produced from the same raw material lot) after completion of fabrication resulting in sheathed thermocouple material.~~ a single length of thermocouple cable produced from the same raw material lots after completion of fabrication.
3.2.2 *cable lot, n*—a quantity of finished mineral-insulated, metal-sheathed thermocouple cable manufactured from tubing or other sheath material from the same heat, wire from the same spool and heat, and insulation from the same batch, then assembled and processed together under controlled production conditions to the required final outside diameter.
3.2.3 *cold-lap, n*—sheath surface defects ~~defect~~ where the sheath surface has been galled and torn by a drawing die and the torn surface smoothed by a subsequent diameter reduction.
3.2.4 *insulation compaction density, n*—the density of a compacted powder is the combined density of the powder particles and of the voids remaining after the powder compaction. Sometimes the insulation compaction density is divided by the theoretical density of the powder particles to obtain a dimensionless fraction of theoretical density as a convenient method to express the relative compaction.
3.2.5 *raw material, n*—~~tubing, insulation and wires used in the fabrication of sheathed thermocouple cable.~~ tubing or other sheath material, insulation and wires used in the fabrication of sheathed thermocouple cable.
3.2.6 *short range ordering, n*—the reversible short-ranged, order-disorder transformation in which the nickel and chromium atoms occupy specific (ordered) localized sites in the Type EP or Type KP thermoelement alloy crystal structure.
3.2.7 ~~thermocouple assembly~~ thermal response time, n—~~the cut-to-length, finished assembly consisting of thermocouple material with thermoelements having one end joined in a measuring junction. The assembly has the sheath closed at the measuring~~

² For referenced ASTM standards, visit the ASTM website, www.astm.org, or contact ASTM Customer Service at service@astm.org. For *Annual Book of ASTM Standards* volume information, refer to the standard's Document Summary page on the ASTM website.

³ Available from American National Standards Institute (ANSI), 25 W. 43rd St., 4th Floor, New York, NY 10036.

end and has a moisture seal at the reference junction end of the sheath. The assembly does not include a reference junction but may include a thermocouple connector, thermocouple extension, or compensating wire. the time required for a sheathed thermocouple signal to attain the specified percent of the total voltage change produced by a step change of temperature at the sheath's outer surface.

4. Summary of Test Methods

4.1 Insulation Properties:

4.1.1 *Compaction*—These tests ensure that the insulation is compacted sufficiently (1) to prevent the insulation from shifting during use with the possibility of the thermoelements shorting to each other or to the sheath, and (2) to have good heat transfer between the sheath and the thermoelements.

4.1.2 *Insulation Resistance*—The insulation ~~must~~shall be free of moisture and contaminants that would compromise the voltage-temperature relationship or shorten the useful life of the sheathed thermocouple. Measurement of insulation resistance is a useful way to detect the presence of unacceptable levels of impurities in the insulation.

4.2 Sheath Properties:

4.2.1 *Integrity*—These tests ensure that (1) the sheath will be impervious to moisture and gases so the insulation and thermoelements will be protected, (2) surface flaws and cracks that might develop into sheath leaks are detected, and (3) the sheath walls are as thick as specified.

4.2.2 *Dimensions*—Determination of length, diameter, and sheath roundness are often necessary to assure proper dimensional fit.

4.2.3 *Sheath Ductility*—The sheath ~~must~~shall be ductile enough to bend the required amount without breaking or cracking.

4.3 Thermoelement Properties Service Life:

4.3.1 *Calibration*—These tests ensure that the temperature-emf relationship corresponds to the standard values both initially and after a short time of heating to service temperatures. This test ensures that the temperature-emf relationship initially corresponds to standardized tolerances.

4.3.2 *Size*—The thermocouple sheath and thermoelement sizes are related to the service life and the thermoelement spacing is related to possible low insulation resistance or shorting.

4.3.3 *Thermoelement Ductility*—Ductility of the thermoelements ~~must~~shall be sufficient to allow the assembly to be bent during assembly or service without significant damage to the thermoelements.

4.4 *Thermocouple Assembly Properties*—The criteria listed above ~~must~~shall apply to both thermocouple assemblies and to bulk cable, ~~and~~ in cable. In addition, the following tests are important for thermocouple assemblies.

4.4.1 *Continuity*—The loop continuity test assures that the thermocouple assembly has a completed circuit.

4.4.2 *Loop Resistance*—The loop resistance test can detect shorted or damaged thermoelements.

4.4.3 *Polarity*—The connector polarity test indicates whether the connector is correctly installed.

4.4.4 *End Seal*—The end seal, if faulty, may allow the contamination of the insulation with moisture or gases. Moisture Seal—The moisture seal at the reference junction end of the thermocouple, if faulty, may allow contamination of the insulation with moisture or gases.

4.4.5 *Radiography*—Radiographic examination of the junction and sheath closure weld can indicate faulty junctions and sheath closures that will lead to early failure. The most internal dimensions can also be measured from the radiograph.

4.4.6 *Response Time*—The thermal response time gives an indication of the quickness with which an installed thermocouple will signal a changing temperature under the test conditions.

4.4.7 *Thermal Cycle*—The thermal cycle test will offer assurance that the thermocouple will not have early failure because of strains imposed from temperature transients.

5. Significance and Use

~~5.1 This test method provides a description of test methods used in ASTM specifications that establish certain acceptable limits for characteristics of thermocouple assemblies and thermocouple cable.~~

~~5.2 The intended use of these test methods is to define the methods by which the characteristics shall be determined.~~

~~5.3 The usefulness and purpose of the included tests are given for the category of tests.~~

5.1 This standard provides a description of test methods used in other ASTM specifications to establish certain acceptable limits for characteristics of thermocouple assemblies and thermocouple cable. These test methods define how those characteristics shall be determined.

5.2 The usefulness and purpose of the included tests are given for the category of tests.

5.3 **Warning**—Users should be aware that certain characteristics of thermocouples might change with time and use. If a thermocouple's designed shipping, storage, installation, or operating temperature has been exceeded, that thermocouple's moisture seal may have been compromised and may no longer adequately prevent the deleterious intrusion of water vapor. Consequently, the thermocouple's condition established by test at the time of manufacture may not apply later. In addition, inhomogeneities can develop in thermoelements because of exposure to higher temperatures, even in cases where maximum exposure temperatures have been lower than the suggested upper use temperature limits specified in Table 1 of Specification E608/E608M. For this reason, calibration of thermocouples destined for delivery to a customer is not recommended. Because the EMF indication of any

thermocouple depends upon the condition of the thermoelements along their entire length, as well as the temperature profile pattern in the region of any inhomogeneity, the EMF output of a used thermocouple will be unique to its installation. Because temperature profiles in calibration equipment are unlikely to duplicate those of the installation, removal of a used thermocouple to a separate apparatus for calibration is not recommended. Instead, *in situ* calibration by comparison to a similar thermocouple known to be good is often recommended.

6. General Requirements

6.1 All the inspection operations are to be performed under clean conditions (that is, conditions that will not degrade the insulation, sheath, or thermoelements), including thermoelements. This includes the use of suitable gloves when appropriate.

6.2 During all process steps in which insulation is exposed to ambient atmosphere, the air ~~must~~shall be clean, with less than 50 % relative humidity, and at a temperature between 20 and 26°C (68 and 79°F).

6.3 All samples which are tested shall be identified by material code, and shall be traceable to a production run.

7. Insulation Properties

7.1 *Insulation Compaction Density*—The thermal conductivity of the insulation, as well as the ability of the insulation to lock the thermoelements into place, will be affected by the insulation compaction density.

7.1.1 Test Methods D2771 is a test on representative specimen to measure the compaction density of electrical grade magnesium oxide. Two methods are used to find the density: Test Method A for water displacement and Test Method B for oil absorption. Both Test Methods A and B require precision weighing and careful procedure.

7.1.2 A direct measurement test of insulation compaction density is applicable if a representative sample can be sectioned so the sample ends are perpendicular to the sample length and the sheath, thermoelements, and insulation form a smooth surface free of burrs. The test procedure is to:

7.1.2.1 Weigh the sample section,

7.1.2.2 Measure the sheath diameter and length with a micrometer,

7.1.2.3 Separate wires, sheath, and insulation by use of an air abrasive tool (air-driven abrasive particles) to remove the insulation from the sample,

7.1.2.4 Weigh the thermoelements and sheath, and

7.1.2.5 Determine the sheath and thermoelements densities either by experiment or from references.

7.1.3 The fraction of the maximum theoretical insulation density is determined as follows:

$$\frac{(A - B)}{[0.785C^2D - (E/F + G/H)J]} \quad (1)$$

(1) $\frac{(A - B)}{[0.785C^2D - (E/F + G/H)J]}$

7.1.1 A direct method for measuring insulation compaction density is applicable if a representative sample can be sectioned so that the sample ends are perpendicular to the sample length and the sheath, thermoelements, and insulation form a smooth surface free of burrs. The procedure is as follows:

7.1.1.1 Weigh the sample section,

7.1.1.2 Measure the sheath diameter and length with a micrometer,

7.1.1.3 Separate the insulation from the thermoelement and sheath with the use of an air abrasive tool,

7.1.1.4 Weigh the thermoelements and sheath, and

7.1.1.5 Determine the sheath and thermoelements densities either by experiment or from references.

7.1.1.6 Determine the percentage of the maximum theoretical insulation density ρ as follows:

$$\% \rho = 100(A - B) / [0.785 C^2 D - (E/F + G/H) J] \quad (1)$$

where:

A = total specimen mass, kg or lb,

B = sheath and wires mass, kg or lb,

C = sheath diameter, m or in.,

D = specimen length, m or in.,

E = sheath mass, kg or lb,

F = sheath density, kg/m³ or lb/in.³,

G = wires mass, kg or lb,

H = wires density (averaged density if applicable), kg/m³ or lb/in.³, and

J = maximum theoretical density of the insulation, kg/m³ or lb/in.³.

7.1.2 Alternately, a liquid absorption method for determining the insulation compaction density may be utilized for MIMS samples with outside diameters 1.5 mm (.062 in.) and larger. This method is based upon a procedure detailed in RDT C 2-1T and requires the following: (1) the sample ends shall be perpendicular to the sample axis and have a smooth, unglazed surface which will readily absorb liquid and shall be free of burrs, (2) the outer surfaces of the thermoelements and the inner surface of the sheath shall be smooth and non-absorbent, and (3) the insulation shall readily support capillary absorption through the entire length of the sample. This procedure is as follows:

7.1.2.1 Determine the density of kerosene for the temperature at which the measurement is being performed if other than 16°C (60°F).

7.1.2.2 Cut a specimen approximately 2.5 mm (1 in.) long.

7.1.2.3 Measure and record the inside diameter of the cable's sheath and the outside diameter of the cable's thermoelements to within .025 mm (.001 in.).

7.1.2.4 Weigh the specimen and record its weight.

7.1.2.5 Measure and record the specimen's length to within .025 mm (.001 in.) using a vernier caliper.

7.1.2.6 Immerse the specimen in kerosene for a minimum of 24 h.

7.1.2.7 Re-weigh the specimen and record its weight.

7.1.2.8 Determine the percentage of the maximum theoretical insulation density ρ as follows:

$$(2) \quad \% \rho = 100 [1 - \{Y - X\} / 0.785 S L \{O^2 - PR\}]$$

L = specimen length, cm or in.,

O = inside diameter of sheath, cm or in.,

P = number of thermoelements in the cable,

R = outside diameter of thermoelements, cm or in.,

S = specific gravity of the kerosene absorbed at 16°C (60°F), .81715 g/cm³ or .02952 lb/in³,

X = weight of the specimen before kerosene is absorbed, g or lb, and

Y = weight of the specimen after kerosene is absorbed, g or lb.

7.2 *Insulation Compaction, Tension Assurance Test Method*—This is a destructive test on representative samples that determines if the thermoelements are locked together with the sheath by the compacted insulation, but this test does not measure the compaction density per se. This test is the complement of the tests of 7.1 and 7.2 that measures the insulation compaction density but does not establish that the thermoelements are locked to the sheath, since there is no established minimum compaction density where locking begins. This test can be performed concurrently with the sheath ductility tension test (in 8.5.3).

7.2.1 Cut a test specimen about 0.5 m (20 in.) long from one end of a bulk material cable length and strip both ends of the specimen to expose a minimum of 10 mm (0.4 in.) of the thermoelements.

7.2.2 Without sealing the exposed insulation, clean the thermoelements (wires) of insulation to provide good electrical contact and twist the wires together on one end to form a thermocouple loop (see Fig. 1).

7.2.3 Measure the electrical resistance of the thermocouple loop to $\pm 0.01 \Omega$ and measure the length of the thermocouple loop to establish the electrical resistance per unit length.

7.2.4 Place the test sample in the tension testing machine so that (1) the grips clamp only on the sample sheath, (2) the force will be applied longitudinally on the sheath, and (3) there is at least a 0.25-m (10-in.) distance between the grips where the force will be applied (see Fig. 2).

7.2.5 Attach an ohmmeter capable of measuring $\pm 0.01 \Omega$ to the exposed thermoelements and measure the resistance with no tension force applied; also measure the distance between the tension tester grips to establish the initial length, L_0 , of the test sample that will be elongated.

7.2.6 Calculate the initial resistance, R_0 , of the test specimen section that will be elongated, using the unit length electrical resistance obtained in 7.2.3.

7.2.7 Make a simultaneous record of the electrical resistance and the elongation of the sheath while stretching the test sample until the thermoelements break.

7.2.8 Examine the exposed ends of the thermoelements to see whether they have been drawn into the insulation during the elongation; any shortening of the exposed ends indicates low compaction of the insulation.

7.2.9 Plot the fractional change of resistance ($\Delta R/R_0$) versus the fractional change of length ($\Delta L/L_0$). The slope of the plot reveals if the thermoelements were locked to the sheath throughout the plastic deformation of the sheath and, if not, where the thermoelements began to elongate in a different manner than the sheath. Examples of criteria to evaluate the insulation locking are given in X1.9

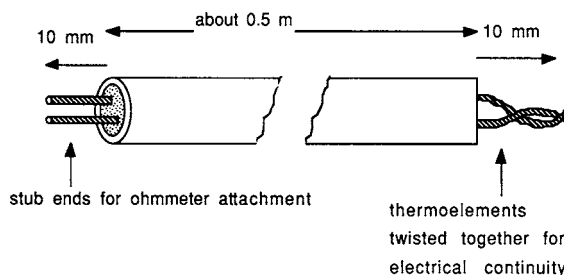

FIG. 1 Specimen of Sheathed Thermocouple Cable Prepared for Tension Testing

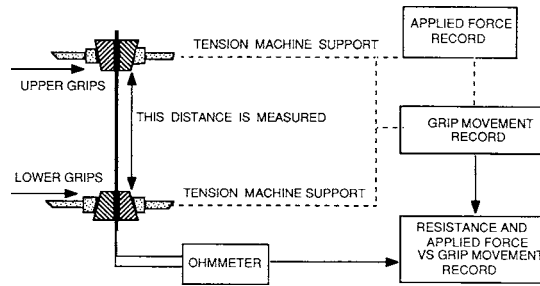

FIG. 2 The Thermocouple Positioned in the Tension Tester

7.3 *Insulation Thickness Measurement*—Determine the dimension—*Determine the insulation thickness, dimension C of Fig. 3 from a metallographic mount, prepared in accordance with Practice E3, using either of the following methods:*

7.3.1 A metallographic mount, prepared in accordance with Practice E3 of a polished cross section of the thermocouple using a microscope having at least a 60× magnification and a 2.5-mm (0.1-in.) reticle graduated in at least 0.03-mm (0.001-in.) increments. Sampling frequency, measurement tolerance, and insulation thickness shall be as stated in the standard specification relevant to the subject thermocouple. Examples of specifications for the insulation thickness are given in the Measuring Junction Configuration section of Specification E608/E608M for the junction area, in the General Dimensional Requirements of Specification E608/E608M, of a polished cross section of the thermocouple or cable using a microscope having at least a 60× magnification and a 2.5-mm (0.1-in.) reticle graduated in at least 0.03-mm (0.001-in.) increments. This measurement test can be done at the same time as the measurements in 8.2.4.1 and 9.4.2.

7.3.2 A radiograph, or a projected enlargement of the radiograph, can be used with the microscope described in 7.3.1 to measure the insulation thickness C of Fig. 3 around the measuring junction. See also 10.7, Radiographic Inspection.

7.3.3 Sampling frequency, measurement tolerance, and insulation thickness shall be as stated in the standard specification relevant to the subject thermocouple. Examples of specifications for the insulation thickness are given in the Measuring Junction Configuration section of Specifications E608/E608M and E2181/E2181M for the junction area, in the General Dimensional Requirements of Specifications E585/E585M and E2181/E2181M and in Tables X1.1 and X1.2.

7.4 *Insulation Resistance, Room Temperature*—Measure the insulation resistance of sheathed thermocouple material/cable at room temperature using Test Method E780. Sampling frequency and insulation resistance shall be as stated in the relevant invoking thermocouple specification, or as agreed upon between the purchaser and the producer. See Table X1.3.

7.5 *Insulation Resistance, Elevated Temperatures*—The purpose of this test is to determine if the thermocouple insulation will be adequate for high temperature use of the thermocouple (**Warning**—All thermocouples may have changes in thermoelectric homogeneity produced by exposure to elevated temperatures; therefore, this test should be regarded as possibly usually destructive.) Sampling frequency shall be as stated in the standard specification relevant to the subject thermocouple.

7.5.1 *Thermocouple Assembly*—Measure the electrical resistance between the thermoelements and the sheath for a Class 2 (ungrounded junction) finished thermocouple assembly (—Measure the electrical resistance between the thermocouple circuit and the sheath of a finished thermocouple assembly with a Style U ungrounded measuring junction (see Fig. 3) using the technique of Test Method E780 (Resistance Measurement).— Insert the measuring junction of the finished thermocouple into a furnace or

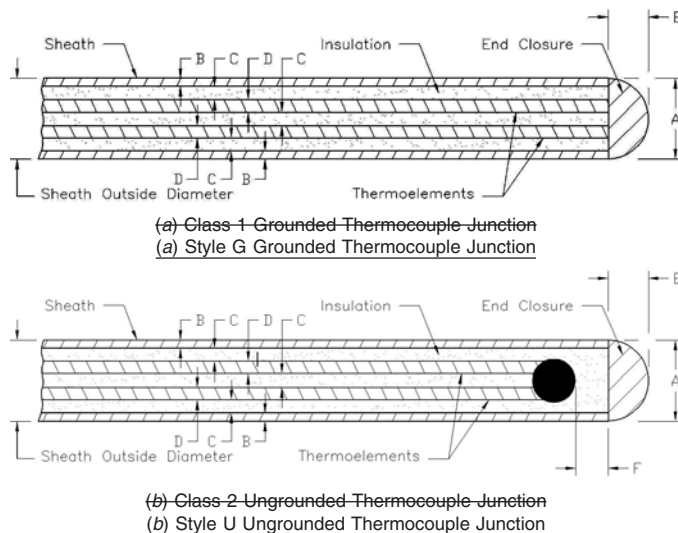

FIG. 3 Sheathed Thermocouple Assembly

constant temperature bath to a depth that will yield maximum temperature stability (example: 20 sheath diameters). Then, the thermocouple junction can be heated to the test temperature. This procedure is not applicable to a Class 1 (grounded junction) Style G grounded measuring junction thermocouple assembly.

7.5.1.1 The minimum acceptable insulation resistance between the thermoelements and the sheath, while the test specimen is at the specified elevated temperature, shall be as stated in the standard specification relevant to the subject thermocouple assembly.

7.5.2 Bulk Cable—Insulation resistance tests on sheathed thermocouple cable at elevated temperatures have the purpose of determining (1) if excess moisture is in the insulation of the bulk cable, or (2) if the insulation contains excess impurities other than moisture, which will affect the insulation resistance at high temperatures.

7.5.2.1 Elevated Temperature, Moisture and Impurities Combined—The steps listed for this test are intended to evaluate the combined effects of insulation impurities on the and moisture contamination using elevated temperature insulation resistance testing of Type K or N bulk material. (cable. **Warning**—Improper technique in constructing thermocouple assemblies can introduce additional insulation impurities and moisture contamination.)

(1) Cut a specimen of approximately 1.2 m (4 ft) in length from the end of the bulk material cable. Strip both ends of the sample about 25 mm (1 in.) to expose the thermoelements and at once seal the ends with an insulating sealant such as epoxy to prevent further moisture absorption. Wind the center section of the specimen around a 25-mm (1-in.) mandrel to form three coils, as shown in Fig. 4. The coils use about 0.3 m (1 ft) of the specimen.

(2) Install a suitable connector on one end of the coil and test the room temperature insulation resistance as described in 7.4.

(3) Insert the sample coil into a furnace and bring the coil temperature to $1000 \pm 10^\circ\text{C}$ ($1832 \pm 18^\circ\text{F}$). The sealed ends of the sample should be kept near room temperature. Allow the sample to stabilize at 1000°C for at least 15 min, (1832°F) as measured by the furnace monitor thermocouple for at least 15 min.

(4) Measure the insulation resistance at the voltage and range appropriate for readability and the thermocouple sheath diameter. The charge time of the megohm tester should be at least 1 min before the measurement is recorded.

(5) Record the insulation resistance between each thermoelement, and from each thermoelement to the sheath.

7.5.2.2 Elevated Temperature, Contaminants Other than Moisture—The steps listed for this test evaluate the effects of impurities in the insulation (other other than moisture) on moisture in the insulation using insulation resistance testing of the bulk material cable at elevated temperatures.

(1) Cut a specimen about 0.6 m (2 ft) long from the end of the bulk material cable to be tested. Strip both ends about 25 mm (1 in.) to expose the thermoelements.

(2) Weld extension wires to each of the thermoelements and to the sheath, as shown in Fig. 5. The extension wires need not be the same composition as the thermoelements, but the extension wire must withstand the temperature of the test and the same composition extension wire should be used for all connections to the specimen.

(3) Wind the center section of the specimen around a 25-mm (1-in.) mandrel to form three coils, as shown in Fig. 5. The coils use about 0.3 m (1 ft) of the sample.

(4) Install a suitable terminal strip or connector to the extension wires, as shown in Fig. 5 and test the room temperature insulation resistance as described in 7.4.

(5) Insert the sample coil into a furnace so that the extension wires are in the same uniform temperature zone as the coil and bring the coil temperature to $1000 \pm 10^\circ\text{C}$ ($1832 \pm 18^\circ\text{F}$). Allow the sample to stabilize at the test temperature for at least 15 min, as measured by the furnace monitor thermocouple for at least 15 min.

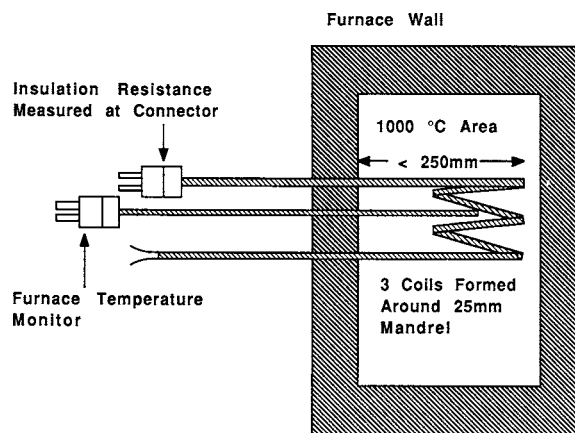

NOTE—The ends of the test specimen are sealed with epoxy to prevent water vapor from being adsorbed or desorbed during the test.

FIG. 4 High Temperature Insulation Resistance Test Assembly to Test for Moisture Plus Impurities

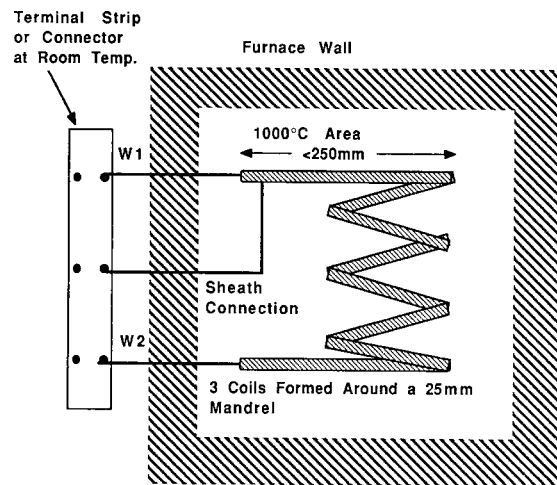

NOTE—The ends of the test specimen are not sealed, allowing water vapor to escape before measuring the insulation resistance

FIG. 5 High Temperature Insulation Resistance Test, Insulation Contamination Other Than Moisture

(6) Measure the insulation resistance at the voltage appropriate for the thermocouple sheath diameter. The charge time of the megohm tester should be at least 1 min before the measurement is recorded.

(7) Record the resistance between each thermoelement, and from each thermoelement to the sheath.

8. Sheath Properties

8.1 *Sheath Integrity*—Leakage of air or moisture into the sheath can be detrimental to the life and local homogeneity of the sheathed thermoelements. Penetrations of the sheath may be caused by holes left during the fabrication of the sheath tubing, cracks due to welding, holes because of incomplete closures at either of the measurement ends, or by other mechanical damage. Two major methods, water penetration and mass spectrometer measurements of helium penetration, are commonly used for assessing to assess sheath integrity. The mass spectrometer method is the most sensitive and the only one that can be used with Class I (grounded junction) Style G grounded measuring junction thermocouples. These sheath integrity test methods are given in order of increasing test sensitivity and difficulty. Before any sheath integrity tests are performed, wipe the sheath with a rag dampened in solvent, such as alcohol, to remove oily surface contaminants.

8.1.1 *Fast Sheath Integrity Test Using Water*—This test is usually a test performed on bulk cable using a less sensitive ohmmeter and a lower voltage test than the test used in 8.1.2; it is the fastest test, intended to detect the larger sheath penetrations.

8.1.1.1 Strip one end of the length to bare a 6 mm (0.25 in.) length of thermoelements.

8.1.1.1 Strip one end of the length of sheathed cable to expose at least 6 mm (0.25 in.) of thermoelements.

8.1.1.2 Check the opposite end of the length for any evidence of shorting of thermoelements to the sheath.

8.1.1.3 Seal the open exposed ends of the compacted oxide insulation with an insulating sealant to prevent the absorption of water vapor.

8.1.1.4 Using a direct-current (dc) ohmmeter, reading to at least 20 MW, megohm, connect the ground lead to the cable sheath and the other test lead to either thermoelement.

8.1.1.5 Then, slowly wipe the length of the sheath with a rag saturated with cold tap water, slowly with water. Apply a light pressure applied to the rag circumferentially around the sheath; when wiping and start wiping from the end opposite the instrument connection.

8.1.1.6 As an alternative, immerse the entire length (in cable length, in a coil if necessary), in tap water, except for 2 %, but not to exceed 0.3 m (1 ft), at each end.

8.1.1.7 With the ohmmeter range selection switch on the most sensitive readable range, interpret any noticeable reduction of insulation resistance as evidence of a leak in the sheath.

8.1.1.8 The leaking section may be cut from the length of material cable and this test repeated to determine the acceptability of the remaining portion of the finished length.

8.1.2 *Basic Sheath Integrity Test Using Water*.

8.1.2.1 Strip one end of the length of sheathed material cable to expose a minimum of at least 6 mm (0.25 in.) of the thermoelements.

8.1.2.2 Check the opposite end of the length for any evidence of shorting of thermoelements to the sheath.

8.1.2.3 Seal the open exposed ends of the compacted oxide insulation with an insulating sealant to prevent the absorption of water vapor.

8.1.2.4 Using a megohmmeter on the most sensitive readable range with an applied voltage at a minimum of 10 Vdc and at a

maximum of 50 Vdc, measure the insulation resistance between the sheath and thermoelements.

8.1.2.5 Then, using a clean rag saturated with unheated tap water (~~water dripping from the rag~~); rag, wipe along the length of the sheath from the end opposite the instrument connection at a rate between 40 to 50 mm/s (7.9 to 9.8 ft/min) applying a light pressure to the rag circumferentially around the sheath, thereby forcing the water into and through any fissure in the sheath wall. Set the ~~material cable~~ aside for at least 30 min after application of the water.

8.1.2.6 A more discriminating method to ensure detecting exceptionally small leaks is to immerse the entire length (coiled if necessary), including the welded measuring junction end, in unheated tap water. Allow up to 2 %, but no more than 0.3 m (1 ft) of length on ends with insulating sealant to remain out of the water. Leave the ~~material cable~~ immersed in the water for a minimum of 16 h.

8.1.2.7 After the exposure to the water as required in 8.1.2.5 or 8.1.2.6, repeat the insulation resistance test of 8.1.2.4. Interpret a noticeable reduction in insulation resistance immediately upon exposure to the water, or after completion of either technique selected, as evidence of a leak in the sheath.

8.1.2.8 A technique to locate the leak, if one is detected, is to leave the voltage applied while the sheathed ~~material cable~~ is exposed to the water. This will often pinpoint the location of a leak by ~~emitted~~ emitting bubbles due to the electrolysis of the water.

8.1.2.9 The leaking section of the length of ~~material cable~~ may be removed and this test repeated to determine acceptability of the remaining portion of the finished length.

8.1.3 *Sheath Integrity, Mass Spectrometer Method:*

8.1.3.1 Test the sheath and measuring end closure as follows: Weld, or otherwise hermetically seal the ~~cold reference junction~~ end to prevent the detrimental absorption of moisture. Wipe the test item clean with a ~~solvent-saturated cloth~~. ~~Recommended solvents are alcohol, methyl ethyl ketone, or methyl isobutyl. (Warning—These solvents can be considered cloth saturated with a solvent such as hazardous and possibly toxic. Refer to applicable Material Safety Data Sheets.)~~ alcohol. Externally pressurize the sheath and measuring end closure with helium to at least 7.0 Mpa (66 atm) for a period of 5 to 10 min. Exclude the ~~cold reference junction~~ end moisture seal from helium pressurization to preclude damage. Wipe the test item again with a solvent-saturated ~~tissue cloth~~ and insert ~~within 2 h it~~ into a test chamber within 2 h of pressurization. Evacuate the interior of this chamber to a pressure of 7 kPa (50 mm Hg) or less, and test for the presence of helium using a mass spectrometer-type helium-leak detector. Monitor the test chamber for a time period of at least three times the ~~System Time Response~~ (system time response (see 8.1.3.3)). Take an indication of helium leakage of 6×10^{-6} standard cubic centimeters per second as evidence of a leak.

8.1.3.2 Determine the sensitivity of the leak detector combined with the evacuated test chamber, hereafter called the system, using a standard leak or a calibrated leak of known leak rate before and after each test, or group of tests, on a given day. If the second sensitivity test shows system sensitivity less than the minimum value specified below, repeat all intervening leak tests on the item being tested.

8.1.3.3 Introduce the standard or calibrated leak into the system at the point farthest from the leak detector. The mass spectrometer-type helium-leak detector shall demonstrate a minimum system sensitivity of 3×10^{-9} standard cubic centimeters of helium per second as indicated on the smallest scale division on the leak detector meter. A leak rate of 6×10^{-9} standard cubic centimeters of helium per second shall produce an additional deflection on the leak-detector meter at least equal to the deflection produced by the combined background and noise signal from the leak detector itself. Perform the system sensitivity test as follows:

(1) With the standard, or calibrated leak at the location described above, introduce the standard leak into the system.

(2) Determine the time required for the leak detector to indicate a constant-leak rate (~~caused~~ caused by the standard ~~leak~~); leak. ~~The System Time Response~~ system time response is defined as the time required to obtain the constant leak-detector indication.

(3) Note the constant-leak rate, and use this value to determine the system sensitivity.

8.2 *Sheath Dimensions*—The sheath dimension ~~tests with~~ measurements shall apply to either bulk cable or completed thermocouple assemblies.

8.2.1 *Sheath Length*—Measure the thermocouple assembly sheath length while the thermocouple assembly is lying straight on a level surface. Gentle axial tension may be applied to the thermocouple assembly to straighten sheath curvature during measurement. Make the measurements from the tip of the sheath closure to the start of the connector, the moisture seal, the transition piece, or the exposed wires (as shown in Fig. 6) using a steel tape or ruler with gradations of 2 mm (0.08 in.) or ~~smaller~~ less.

8.2.2 *Sheath Diameter*—Measure the outside diameter of the sheath at five random points along its length with an optical comparator, diameter gage, micrometer, or micrometer vernier calipers. If a micrometre or vernier calipers is used, readings ~~are~~ shall be taken 90° – 120° apart at each measurement point. Limits of sheath diameter variation shall be as stated in the standard specification relevant to the subject thermocouple. See Table X1.4.

8.2.3 *Sheath Roundness*—~~The difference between the maximum and minimum outside diameter shall be considered the roundness tolerance and shall be determined by a micrometer reading to find the high and low points around the circumference at any one cross section of the sheath. The value of roundness tolerance shall be as stated in the standard specification relevant to the subject thermocouple. See~~ The difference between the maximum and minimum outside diameter measurements at any of the points from 8.2.2 shall be considered the roundness. The value of roundness tolerance shall be as stated in the standard specification relevant to the subject thermocouple. See X1.4.

8.2.4 *Sheath Wall Thickness*—Determine the sheath wall thickness, dimension B of Fig. 3, ~~from a metallographic mount~~