Prosthetics — Geometrical aspects of lower limb prosthetic adapters

*Prothèses — Aspects géométriques des adaptateurs de prothèses de
membres inférieurs*

iTeh STANDARD PREVIEW
(standards.iteh.ai)

[ISO 24562:2022](https://standards.iteh.ai/catalog/standards/sist/8273a4ec-b6cd-4c60-9e05-d70c72947b1a/iso-24562-2022)

<https://standards.iteh.ai/catalog/standards/sist/8273a4ec-b6cd-4c60-9e05-d70c72947b1a/iso-24562-2022>



iTeh STANDARD PREVIEW
(standards.iteh.ai)

ISO 24562:2022

<https://standards.iteh.ai/catalog/standards/sist/8273a4ec-b6cd-4c60-9e05-d70c72947b1a/iso-24562-2022>



COPYRIGHT PROTECTED DOCUMENT

© ISO 2022

All rights reserved. Unless otherwise specified, or required in the context of its implementation, no part of this publication may be reproduced or utilized otherwise in any form or by any means, electronic or mechanical, including photocopying, or posting on the internet or an intranet, without prior written permission. Permission can be requested from either ISO at the address below or ISO's member body in the country of the requester.

ISO copyright office
CP 401 • Ch. de Blandonnet 8
CH-1214 Vernier, Geneva
Phone: +41 22 749 01 11
Email: copyright@iso.org
Website: www.iso.org

Published in Switzerland

Contents

	Page
Foreword.....	iv
1 Scope.....	1
2 Normative references.....	1
3 Terms and definitions.....	1
4 Geometrical aspects of mating connectors (adapters).....	1
4.1 General.....	1
4.2 Convex connector.....	2
4.3 Concave connector.....	2
5 Risk evaluation and testing.....	3

iTeh STANDARD PREVIEW
(standards.iteh.ai)

[ISO 24562:2022](https://standards.iteh.ai/catalog/standards/sist/8273a4ec-b6cd-4c60-9e05-d70c72947b1a/iso-24562-2022)

<https://standards.iteh.ai/catalog/standards/sist/8273a4ec-b6cd-4c60-9e05-d70c72947b1a/iso-24562-2022>

Foreword

ISO (the International Organization for Standardization) is a worldwide federation of national standards bodies (ISO member bodies). The work of preparing International Standards is normally carried out through ISO technical committees. Each member body interested in a subject for which a technical committee has been established has the right to be represented on that committee. International organizations, governmental and non-governmental, in liaison with ISO, also take part in the work. ISO collaborates closely with the International Electrotechnical Commission (IEC) on all matters of electrotechnical standardization.

The procedures used to develop this document and those intended for its further maintenance are described in the ISO/IEC Directives, Part 1. In particular, the different approval criteria needed for the different types of ISO documents should be noted. This document was drafted in accordance with the editorial rules of the ISO/IEC Directives, Part 2 (see www.iso.org/directives).

Attention is drawn to the possibility that some of the elements of this document may be the subject of patent rights. ISO shall not be held responsible for identifying any or all such patent rights. Details of any patent rights identified during the development of the document will be in the Introduction and/or on the ISO list of patent declarations received (see www.iso.org/patents).

Any trade name used in this document is information given for the convenience of users and does not constitute an endorsement.

For an explanation of the voluntary nature of standards, the meaning of ISO specific terms and expressions related to conformity assessment, as well as information about ISO's adherence to the World Trade Organization (WTO) principles in the Technical Barriers to Trade (TBT), see www.iso.org/iso/foreword.html.

This document was prepared by Technical Committee ISO/TC 168, *Prosthetics and orthotics*.

Any feedback or questions on this document should be directed to the user's national standards body. A complete listing of these bodies can be found at www.iso.org/members.html.

Prosthetics — Geometrical aspects of lower limb prosthetic adapters

1 Scope

This document specifies dimensions of the adult modular systems adapters used in lower limb prosthetic.

2 Normative references

The following documents are referred to in the text in such a way that some or all of their content constitutes requirements of this document. For dated references, only the edition cited applies. For undated references, the latest edition of the referenced document (including any amendments) applies.

ISO 10328, *Prosthetics — Structural testing of lower-limb prostheses — Requirements and test methods*

ISO 22523, *External limb prostheses and external orthoses — Requirements and test methods*

ISO 22675, *Prosthetics — Testing of ankle-foot devices and foot units — Requirements and test methods*

3 Terms and definitions

For the purposes of this document, the following terms and definitions apply.

ISO and IEC maintain terminology databases for use in standardization at the following addresses:

- ISO Online browsing platform: available at <https://www.iso.org/obp>
- IEC Electropedia: available at <https://www.electropedia.org/>

3.1

modular connector

adapter used in lower limb prosthetic assembly

3.2

convex connector

connecting part of the modular adapter with an inverted pyramid

3.3

concave connector

receiving part of the modular adapter with a pyramid receiver

4 Geometrical aspects of mating connectors (adapters)

4.1 General

Concave: Pyramid receiver

Convex: Pyramid connector

If a modular connector is used as an adjustable connector between prosthetic components, weaknesses of the connection can occur if the contact area of the convex and concave surfaces does not establish the largest possible diameter.

Two measures are supporting the essential contact condition:

- a) the radius, including tolerances, of the convex dome shall be larger than the radius of the concave dome;
- b) the concave surface is designed as an outer ring that is limited in its width. Closer to the pyramid receiver, a sufficient recess prevents any further contact between the concave and convex surface.

NOTE Examples of different manufacturers who show that a radius of 25,00 mm is used for the critical dimension connecting the concave and convex dome. The outer diameter of the ring-shaped concave contact area is limited by the intended angular range of adjustment of the modular connection. The inner diameter of that ring provides sufficient width of the contact surface to ensure defined contact area and prevent possible failures in the connection.

4.2 Convex connector

The convex connector outline is shown in [Figure 1](#). [Table 1](#) lists the convex connector dimension and tolerance.

Table 1 — Convex connector geometry

Dimension ID	Description	Dimension	Tolerance
D_1	Pyramid connector dome radius	25,00 mm	Min. 25,00 mm – Max. 25,60 mm

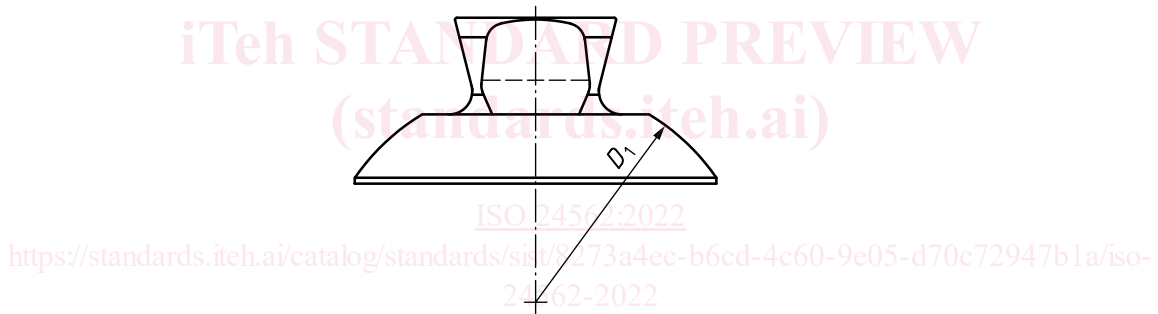

Figure 1 — Convex connector outline

4.3 Concave connector

The concave connector outline is shown in [Figure 2](#). [Table 2](#) lists the concave connector dimension and tolerance.

Table 2 — Concave connector geometry

Dimension ID	Description	Dimension	Tolerance
D_1	Pyramid receiver dome radius	24,70 mm	Min. 24,40 mm – Max. 24,99 mm

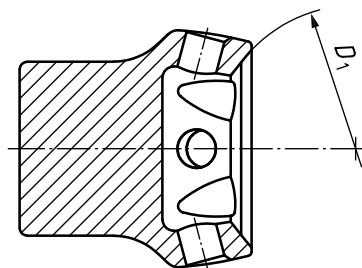

Figure 2 — Concave connector outline

5 Risk evaluation and testing

Components manufactured according to this document shall be in accordance with ISO 22523.

The samples constructed for testing to ISO 10328 and ISO 22675 using the modular systems shall be utilized with the dimensions of these interfaces.

iTeh STANDARD PREVIEW
(standards.iteh.ai)

[ISO 24562:2022](https://standards.iteh.ai/catalog/standards/sist/8273a4ec-b6cd-4c60-9e05-d70c72947b1a/iso-24562-2022)

<https://standards.iteh.ai/catalog/standards/sist/8273a4ec-b6cd-4c60-9e05-d70c72947b1a/iso-24562-2022>