

PUBLICLY
AVAILABLE
SPECIFICATION

ISO/PAS
24565

First edition

**Petroleum and natural gas
industries — Ceramic lined tubing**

*Industries du pétrole et du gaz naturel — Tubes de production avec
revêtement céramique*

iTeh STANDARD PREVIEW
(standards.iteh.ai)

[ISO/PRF PAS 24565](https://standards.iteh.ai/catalog/standards/sist/658ea7fb-493a-443e-8ae8-2f83a87c35ad/iso-prf-pas-24565)

[https://standards.iteh.ai/catalog/standards/sist/658ea7fb-493a-443e-8ae8-
2f83a87c35ad/iso-prf-pas-24565](https://standards.iteh.ai/catalog/standards/sist/658ea7fb-493a-443e-8ae8-2f83a87c35ad/iso-prf-pas-24565)

PROOF / ÉPREUVE



Reference number
ISO/PAS 24565:2021(E)

© ISO 2021

iTeh STANDARD PREVIEW (standards.iteh.ai)

[ISO/PRF PAS 24565](https://standards.iteh.ai/catalog/standards/sist/658ea7fb-493a-443e-8ae8-2f83a87c35ad/iso-prf-pas-24565)

<https://standards.iteh.ai/catalog/standards/sist/658ea7fb-493a-443e-8ae8-2f83a87c35ad/iso-prf-pas-24565>



COPYRIGHT PROTECTED DOCUMENT

© ISO 2021

All rights reserved. Unless otherwise specified, or required in the context of its implementation, no part of this publication may be reproduced or utilized otherwise in any form or by any means, electronic or mechanical, including photocopying, or posting on the internet or an intranet, without prior written permission. Permission can be requested from either ISO at the address below or ISO's member body in the country of the requester.

ISO copyright office
CP 401 • Ch. de Blandonnet 8
CH-1214 Vernier, Geneva
Phone: +41 22 749 01 11
Email: copyright@iso.org
Website: www.iso.org

Published in Switzerland

Contents

	Page
Foreword.....	v
Introduction.....	vi
1 Scope.....	1
2 Normative references.....	1
3 Terms, definitions, symbols and abbreviated terms.....	2
3.1 Terms and definitions.....	2
3.2 Symbols and abbreviated terms.....	3
3.2.1 Symbols.....	3
3.2.2 Abbreviated terms.....	3
4 CLT configuration and materials.....	4
4.1 Configuration.....	4
4.2 Pipe ends.....	5
4.3 Connection type.....	5
4.4 Material requirements.....	6
4.4.1 Backing pipe.....	6
4.4.2 Thermite.....	6
4.4.3 End cap and CB ring.....	6
5 Manufacturing.....	6
5.1 Treatment of backing pipe.....	6
5.1.1 Distinguishing of the used tubing.....	6
5.1.2 Blast-cleaning.....	7
5.1.3 Straightening of the used tubing.....	7
5.2 Manufacture of CLT.....	7
5.2.1 Thermite mixing.....	7
5.2.2 Filling.....	7
5.2.3 Lining.....	7
5.2.4 Heat treatment.....	7
5.2.5 Installation of the end cap.....	7
5.2.6 Threading.....	7
5.3 Manufacture of CB Ring.....	8
5.4 Installation of CB Rings.....	8
5.5 Traceability.....	8
5.6 Purchaser inspection.....	8
6 Inspection and testing.....	8
6.1 General.....	8
6.2 Inspection of backing pipe.....	8
6.3 Inspection of ceramic liner.....	9
6.3.1 Surface.....	9
6.3.2 Thickness.....	9
6.3.3 Hardness and density.....	9
6.4 Inspection of CLT.....	9
6.4.1 Dimensions test.....	9
6.4.2 Length measurement.....	9
6.4.3 Straightness evaluation.....	10
6.4.4 Thread and end cap inspection.....	10
6.4.5 Drift test.....	11
6.4.6 Hydrostatic test.....	11
6.4.7 Corrosion test.....	11
6.4.8 Tensile and impact test.....	12
6.4.9 Connection test.....	12
6.5 Additional tests.....	12
6.5.1 General.....	12

6.5.2	Impact test.....	12
6.5.3	Crushing strength test.....	12
6.5.4	Bonding strength test.....	12
6.5.5	Bending test.....	13
6.5.6	Thermal shock test.....	14
6.6	CB ring test.....	14
6.7	End cap test.....	14
6.8	Inspection frequency and acceptance criteria.....	14
6.8.1	Lot.....	14
6.8.2	Inspection frequency.....	14
6.8.3	Acceptance criteria.....	15
7	Documentation.....	15
7.1	Documents provided by the purchaser.....	15
7.2	Documents provided by the manufacturer.....	16
8	Marking, packaging, transportation, and storage.....	16
8.1	Marking.....	16
8.2	Packaging.....	17
8.3	Transportation.....	17
8.4	Storage.....	17
	Annex A (informative) Testing method for surface quality of ceramic liner.....	18
	Annex B (normative) List of CLT products.....	19
	Annex C (informative) Testing method of ceramic liner thickness.....	23
	Bibliography.....	25

Iteh STANDARD PREVIEW
(standards.iteh.ai)

[ISO/PRF PAS 24565](https://standards.iteh.ai/catalog/standards/sist/658ea7fb-493a-443e-8ae8-2f83a87c35ad/iso-prf-pas-24565)

<https://standards.iteh.ai/catalog/standards/sist/658ea7fb-493a-443e-8ae8-2f83a87c35ad/iso-prf-pas-24565>

Foreword

ISO (the International Organization for Standardization) is a worldwide federation of national standards bodies (ISO member bodies). The work of preparing International Standards is normally carried out through ISO technical committees. Each member body interested in a subject for which a technical committee has been established has the right to be represented on that committee. International organizations, governmental and non-governmental, in liaison with ISO, also take part in the work. ISO collaborates closely with the International Electrotechnical Commission (IEC) on all matters of electrotechnical standardization.

The procedures used to develop this document and those intended for its further maintenance are described in the ISO/IEC Directives, Part 1. In particular, the different approval criteria needed for the different types of ISO documents should be noted. This document was drafted in accordance with the editorial rules of the ISO/IEC Directives, Part 2 (see www.iso.org/directives).

Attention is drawn to the possibility that some of the elements of this document may be the subject of patent rights. ISO shall not be held responsible for identifying any or all such patent rights. Details of any patent rights identified during the development of the document will be in the Introduction and/or on the ISO list of patent declarations received (see www.iso.org/patents).

Any trade name used in this document is information given for the convenience of users and does not constitute an endorsement.

For an explanation of the voluntary nature of standards, the meaning of ISO specific terms and expressions related to conformity assessment, as well as information about ISO's adherence to the World Trade Organization (WTO) principles in the Technical Barriers to Trade (TBT), see www.iso.org/iso/foreword.html (standards.iteh.ai)

This document was prepared by Technical Committee ISO/TC 67, *Materials, equipment and offshore structures for petroleum, petrochemical and natural gas industries*, Subcommittee SC 5, *Casing, tubing and drill pipe*.
ISO/PRF PAS 24565
<https://standards.iteh.ai/catalog/standards/sist/658ea7fb-493a-443e-8ae8-2f83a87c35ad/iso-prf-pas-24565>

Any feedback or questions on this document should be directed to the user's national standards body. A complete listing of these bodies can be found at www.iso.org/members.html.

Introduction

Users of this document should be aware that further or differing requirements can be needed for individual applications. This document is not intended to inhibit a manufacturer from offering, or the purchaser from accepting, alternative equipment or engineering solutions for the individual application. This can be particularly applicable where there is innovative or developing technology. Where an alternative is offered, it is the responsibility of the manufacturer to identify and provide details of any variations from this document.

In this document, the following verbal forms are used:

- “shall” indicates a requirement;
- “should” indicates a recommendation;
- “can” indicates a possibility or a capability;
- “may” indicates a permission.

iTeh STANDARD PREVIEW (standards.iteh.ai)

[ISO/PRF PAS 24565](https://standards.iteh.ai/catalog/standards/sist/658ea7fb-493a-443e-8ae8-2f83a87c35ad/iso-prf-pas-24565)

<https://standards.iteh.ai/catalog/standards/sist/658ea7fb-493a-443e-8ae8-2f83a87c35ad/iso-prf-pas-24565>

Petroleum and natural gas industries — Ceramic lined tubing

1 Scope

This document specifies requirements for ceramic lined tubing (CLT) used in the petroleum and natural gas industries, including configuration and materials, manufacturing, inspection and testing, marking, packaging, transportation, and storage.

This document is applicable to CLT manufactured by centrifugal self-propagating high-temperature synthesis.

The applicable pipe outside diameter of CLT ranges from 42,16 mm (1,66 inch) to 114,3 mm (4-1/2 inch). The steel grades include H40, J55, and N80 type 1.

NOTE Applicability of this document to other sizes and higher steel grades can be by agreement between the manufacturer and the purchaser.

CLT is suitable for extracting multiphase fluid, hydrocarbon gas, hydrocarbon liquid, and water under corrosive, abrasive, wax deposition, scaling, and high temperature environments.

iTeh STANDARD PREVIEW

2 Normative references (standards.iteh.ai)

The following documents are referred to in the text in such a way that some or all of their content constitutes requirements of this document. For dated references, only the edition cited applies. For undated references, the latest edition of the referenced document (including any amendments) applies.

ISO 2819, *Metallic coatings on metallic substrates — Electrodeposited and chemically deposited coatings — Review of methods available for testing adhesion*

ISO 2859-1, *Sampling procedures for inspection by attributes — Part 1: Sampling schemes indexed by acceptance quality limit (AQL) for lot-by-lot inspection*

ISO 8501-1, *Preparation of steel substrates before application of paints and related products — Visual assessment of surface cleanliness — Part 1: Rust grades and preparation grades of uncoated steel substrates and of steel substrates after overall removal of previous coatings*

ISO 10405, *Petroleum and natural gas industries — Care and use of casing and tubing*

ISO 11960, *Petroleum and natural gas industries — Steel pipes for use as casing or tubing for wells*

ISO 14705, *Fine ceramics (advanced ceramics, advanced technical ceramics) — Test method for hardness of monolithic ceramics at room temperature*

ISO 15156-2, *Petroleum and natural gas industries — Materials for use in H₂S-containing environments in oil and gas production — Part 2: Cracking-resistant carbon and low-alloy steels, and the use of cast irons*

ISO 21714, *Fine ceramics (advanced ceramics, advanced technical ceramics) — Test method for determining density of ceramic coatings*

ISO 23936-1, *Petroleum, petrochemical and natural gas industries – Non-metallic materials in contact with media related to oil and gas production –Part 1: Thermoplastics*

API Spec 5B, *Specification for Threading, Gauging, and Thread Inspection of Casing, Tubing, and Line Pipe Threads*

ASTM A700, *Standard Guide for Packaging, Marking, and Loading Methods for Steel Products for Shipment*

ASTM D5420, *Standard Test Method for Impact Resistance of Flat, Rigid Plastic Specimen by Means of a Striker Impacted by a Falling Weight (Gardner Impact)*

ASTM G31, *Standard Guide for Laboratory Immersion Corrosion Testing of Metals*

3 Terms, definitions, symbols and abbreviated terms

3.1 Terms and definitions

For the purposes of this document, the following terms and definitions apply.

ISO and IEC maintain terminology databases for use in standardization at the following addresses:

- ISO Online browsing platform: available at <https://www.iso.org/obp>
- IEC Electropedia: available at <https://www.electropedia.org/>

3.1.1

backing pipe

tubing before being lined with ceramic liner

3.1.2

bonding strength

shear strength required to shear the ceramic liner along the axial direction of the backing pipe

3.1.3

centrifugal self-propagating high-temperature synthesis

centrifugal SHS

self-propagating high-temperature synthesis under the centrifugal force generated by high-speed rotation, which is helpful to promote reaction and phase separation of molten products

Note 1 to entry: The centrifugal self-propagating high-temperature synthesis technology comprises the following steps. Fill Fe_2O_3 (or Fe_3O_4) powder and aluminium powder with a given proportion into a steel tubing. Fix the tubing with the powder on a centrifuge and rotate it at a high speed. Then, start the reaction when the rotating speed reaches a given value. The reaction can be maintained due to a large amount of reaction heat released by the exothermic reaction. Under the action of centrifugal force, molten products are separated into layers from each other due to the difference in their specific gravity, and after cooling, ceramic lined tubing is formed.

3.1.4

ceramic liner

ceramic layer formed on the inner wall of the backing pipe by centrifugal self-propagating high-temperature synthesis method

Note 1 to entry: It is attached to the inner wall of the backing pipe and has the functions of corrosion prevention, scale prevention, and wear resistance.

3.1.5

ceramic lined tubing

CLT

tubing with a ceramic liner stuck on to its inner wall made by centrifugal self-propagating high-temperature synthesis

3.1.6

corrosion barrier ring

CB ring

polymeric ring inserted between adjacent lengths of liner in a tubing string to provide continuity of corrosion protection

3.1.7**crushing strength**

fracture strength of the ceramic liner when applying radial compression load on ceramic lined tubing

3.1.8**end cap**

metal component used to seal the cut end of ceramic liner

3.1.9**flare of the end cap**

edge formed by turning the outer edge of the end cap along the cross-section of the backing pipe

3.1.10**Label 1**

dimensionless designation for the size or specified outside diameter that can be used when ordering the pipe

Note 1 to entry: See [Table B.1](#).

3.1.11**Label 2**

dimensionless designation for the mass per unit length that can be used when ordering the pipe

Note 1 to entry: See [Table B.1](#).

3.1.12**self-propagating high-temperature synthesis****SHS**

technique for synthesizing materials by using the heat released by the exothermic reaction to make the reaction proceed spontaneously

3.1.13**thermite**

mixture of aluminium powder, metal oxides (such as Fe_2O_3 or Fe_3O_4) and related additives that generate a large amount of heat when ignited

STANDARD PREVIEW
(standards.iteh.ai)
ISO/PRF PAS 24565
<https://standards.iteh.ai/catalog/standards/sist/658ea7fb-493a-443e-8ae8-2f83a87c35ad/iso-prf-pas-24565>

3.2 Symbols and abbreviated terms**3.2.1 Symbols**

d inside diameter of ceramic lined tubing

t wall thickness of backing pipe

3.2.2 Abbreviated terms

AQL acceptance quality limit

CAL connection assessment level

CB corrosion barrier

CLT ceramic lined tubing

EU API Spec 5B external upset tubing connection

HIC hydrogen induced cracking

NU API Spec 5B non-upset tubing connection

OD	outside diameter of CLT
PTFE	polytetrafluoroethylene
SCC	stress corrosion cracking
SSC	sulfide stress cracking

4 CLT configuration and materials

4.1 Configuration

CLT consists of backing pipe and ceramic liner. The typical configuration of CLT is shown in [Figure 1](#) and [Figure 2](#).

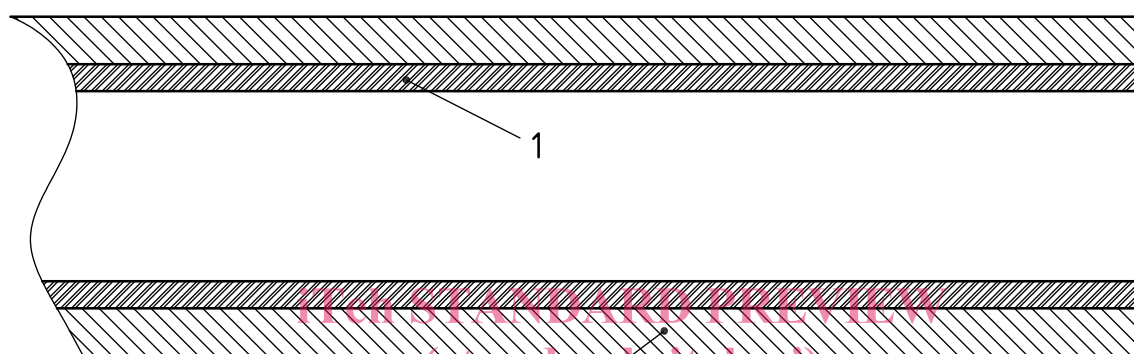

Key

- 1 ceramic liner
- 2 backing pipe

ISO/PRF PAS 24565
<https://standards.iteh.ai/catalog/standards/sist/658ea7fb-493a-443e-8ae8-2f83a87c35ad/iso-prf-pas-24565>

Figure 1 — Configuration of CLT body

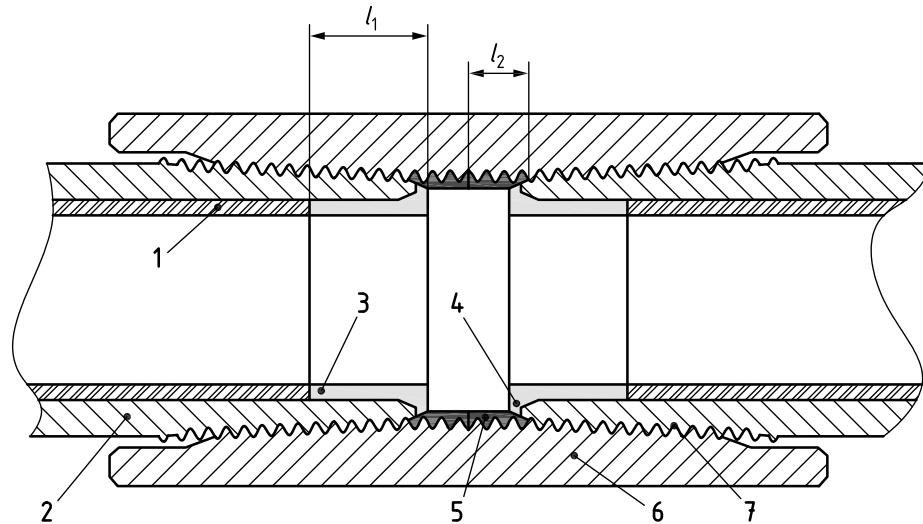
**Key**

- 1 ceramic liner
- 2 backing pipe
- 3 end cap
- 4 flare of the end cap
- 5 CB ring
- 6 coupling
- 7 threads
- l_1 end cap length
- l_2 CB ring length

iTeh STANDARD PREVIEW
(standards.iteh.ai)

ISO/PRF PAS 24565

<https://standards.iteh.ai/catalog/standards/sist/658ea7fb-493a-443e-8ae8->

Figure 2 — Example of configuration of CLT coupling based on API Spec 5B (round) thread

4.2 Pipe ends

Unless otherwise specified by the purchaser, CLT shall be supplied with API Spec 5B threads at both ends and with corresponding couplings. If agreed by the manufacturer and the purchaser, CLT may be supplied without couplings, and/or with plain ends, and/or with connections specified by the purchaser.

4.3 Connection type

Lengths of CLT are connected with each other with coupling, as shown in [Figure 2](#). In this example involving the API 5B connections, the continuity between ceramic liners is ensured by using an end cap or flare as well as a polymeric CB rings. This assembly aims at protecting the coupling or pin extremities from any contact with the production fluid that could induce corrosion. Other forms of coupling protection devices are acceptable. Polymeric CB rings are usually provided on the inner wall of coupling to ensure the integrity of anti-corrosion between adjacent tubing lengths. The amount of compression applied to the CB ring is controlled by the distance between the pin ends during make-up.

The pipe ends can be protected from corrosion by an end cap or flare, which will extend over the whole pipe end (i.e. over the whole pipe wall thickness) so to allow matching the selected connection. The flare of the end cap is tightly attached to the CB ring on the coupling, thus ensuring the integrity of the whole connecting structure.

Other types of connection, such as premium connection, may also be used. In such a case, the coupling protection shall be adjusted to the proprietary design.

4.4 Material requirements

4.4.1 Backing pipe

When using new tubing as the backing pipe, its dimensions and properties shall conform to the requirements of ISO 11960. When used in a sour environment, the backing pipe shall conform to the requirements of resistance to sulfide stress cracking as specified in ISO 15156-2.

Previously-used tubing may also be used as the backing pipe. Typical well or conditions where these products can be used are general water injection, layered water injection and oil extraction. The minimum wall thickness of the used tubing shall be greater than 2,8 mm, unless otherwise agreed. The technical requirements for material, performance, and testing of the used tubing should be determined based on experiences of the purchaser and manufacturer and the requirements of working conditions. At least, mechanical properties during tension and impact and the hardness of the used tubing shall conform to the requirements of ISO 11960. Tubing previously used in a sour environment is not recommended for use as a backing pipe.

4.4.2 Thermitite

Inert gas atomized aluminium powder with an active aluminium content of not less than 98 wt.% should be used as the thermitite. The particle size of aluminium powder should be not less than 200 mesh (75 µm).

Industrial grade Fe₂O₃ (or Fe₃O₄) powder should be used with the particle size of not less than 200 mesh (75 µm).

iTeh STANDARD PREVIEW
(standards.iteh.ai)

4.4.3 End cap and CB ring

The end cap shall be compatible with the fluid to be transported. It is usually made of stainless steel and is bonded to the ceramic liner with a suitable adhesive. Other types of end cap materials shall meet the requirements of relevant standards.

CB rings are typically made from polymer materials that meet the requirements of corrosion, temperature, and wear resistance for the bore fluids, usually, elastomers or fiber-filled PTFE.

The length of the end cap l_1 shall conform to the requirements in [Table 1](#). The length of the CB ring l_2 shall be designed according to connection type.

Table 1 — Length range of end cap

Label 1	End cap length, l_1 mm
≤2-7/8	20 to 25
>2-7/8	25 to 30

5 Manufacturing

5.1 Treatment of backing pipe

5.1.1 Distinguishing of the used tubing

Manufacturers and/or used tubing suppliers should establish procedures or basis for identifying and distinguishing the steel grade of used tubing. Element analysis, metallographic structure analysis and mechanical properties test are available procedures and/or references. The standard colour code for the steel grade should be then painted onto the used tubing.