



International
Standard

ISO 16000-11

Indoor air —

Part 11:

**Determination of the emission of
volatile organic compounds from
samples of building products and
furnishing — Sampling, storage of
samples and preparation of test
specimens**

**Second edition
2024-03**

[ISO 16000-11:2024](#)

Air intérieur — [ards.iteh.ai/catalog/standards/iso/43e0297d-7fd5-4c10-a20c-1912030a15c7/iso-16000-11-2024](#)

*Partie 11: Dosage de l'émission de composés organiques
volatils d'échantillons de produits de construction et d'objets
d'équipement — Échantillonnage, conservation des échantillons
et préparation des éprouvettes d'essais*

iTeh Standards
(<https://standards.iteh.ai>)
Document Preview

[ISO 16000-11:2024](https://standards.iteh.ai/catalog/standards/iso/43e0297d-7fd5-4c10-a20c-1912030a15c7/iso-16000-11-2024)

<https://standards.iteh.ai/catalog/standards/iso/43e0297d-7fd5-4c10-a20c-1912030a15c7/iso-16000-11-2024>



COPYRIGHT PROTECTED DOCUMENT

© ISO 2024

All rights reserved. Unless otherwise specified, or required in the context of its implementation, no part of this publication may be reproduced or utilized otherwise in any form or by any means, electronic or mechanical, including photocopying, or posting on the internet or an intranet, without prior written permission. Permission can be requested from either ISO at the address below or ISO's member body in the country of the requester.

ISO copyright office
CP 401 • Ch. de Blandonnet 8
CH-1214 Vernier, Geneva
Phone: +41 22 749 01 11
Email: copyright@iso.org
Website: www.iso.org

Published in Switzerland

Contents

	Page
Foreword	iv
Introduction	v
1 Scope	1
2 Normative references	1
3 Terms and definitions	1
4 Sampling the product and transport and storage of sample	2
4.1 Sampling of the product to be tested.....	2
4.2 Sample packaging and transport.....	2
4.3 Sample description.....	2
4.4 Storage of the sample prior to starting the testing.....	2
5 Preparation of test specimens	3
Annex A (informative) Solid products — Procedure for sampling and test specimen preparation	4
Annex B (informative) Liquid products — Procedure for sampling and test specimen preparation	7
Annex C (informative) Combined products	11
Annex D (informative) Cut edges emission	13
Bibliography	14

iTech Standards
(<https://standards.iteh.ai>)
Document Preview

[ISO 16000-11:2024](https://standards.iteh.ai/catalog/standards/iso/43e0297d-7fd5-4c10-a20c-1912030a15c7/iso-16000-11-2024)

<https://standards.iteh.ai/catalog/standards/iso/43e0297d-7fd5-4c10-a20c-1912030a15c7/iso-16000-11-2024>

Foreword

ISO (the International Organization for Standardization) is a worldwide federation of national standards bodies (ISO member bodies). The work of preparing International Standards is normally carried out through ISO technical committees. Each member body interested in a subject for which a technical committee has been established has the right to be represented on that committee. International organizations, governmental and non-governmental, in liaison with ISO, also take part in the work. ISO collaborates closely with the International Electrotechnical Commission (IEC) on all matters of electrotechnical standardization.

The procedures used to develop this document and those intended for its further maintenance are described in the ISO/IEC Directives, Part 1. In particular, the different approval criteria needed for the different types of ISO document should be noted. This document was drafted in accordance with the editorial rules of the ISO/IEC Directives, Part 2 (see www.iso.org/directives).

ISO draws attention to the possibility that the implementation of this document may involve the use of (a) patent(s). ISO takes no position concerning the evidence, validity or applicability of any claimed patent rights in respect thereof. As of the date of publication of this document, ISO had not received notice of (a) patent(s) which may be required to implement this document. However, implementers are cautioned that this may not represent the latest information, which may be obtained from the patent database available at www.iso.org/patents. ISO shall not be held responsible for identifying any or all such patent rights.

Any trade name used in this document is information given for the convenience of users and does not constitute an endorsement.

For an explanation of the voluntary nature of standards, the meaning of ISO specific terms and expressions related to conformity assessment, as well as information about ISO's adherence to the World Trade Organization (WTO) principles in the Technical Barriers to Trade (TBT), see www.iso.org/iso/foreword.html.

This document was prepared by Technical Committee ISO/TC 146, *Air quality*, Subcommittee SC 6, *Indoor air*, in collaboration with the European Committee for Standardization (CEN) Technical Committee CEN/TC 264, *Air quality*, in accordance with the Agreement on technical cooperation between ISO and CEN (Vienna Agreement).

This second edition cancels and replaces the first edition (ISO 16000-11:2006), which has been technically revised.

The main changes are as follows:

- detailed descriptions for the preparation of samples of liquid products like paints, varnishes and impregnating primers have been added;
- the wet layer thickness instead of the dry film thickness for preparing liquid samples have been recommended;
- sample preparation instructions have been added to determine the cut edge emissions.

A list of all parts in the ISO 16000 series can be found on the ISO website.

Any feedback or questions on this document should be directed to the user's national standards body. A complete listing of these bodies can be found at www.iso.org/members.html.

Introduction

The determination of volatile organic compounds (VOCs) emitted from building products and furnishing using emission test chambers in conjunction with the standardised sampling, storage of samples and preparation of test specimens has objectives such as:

- to provide manufacturers, builders and end users with emission data useful for the evaluation of the impact of building products on the indoor air quality;
- to promote the development of improved products.

Studies of the emission of volatile organic compounds from building products or furnishing in test chambers or cells require proper handling of the product prior to testing and during the testing period.

The method can in principle be used for most building products and furnishings used indoors.

NOTE Depending on the non-homogeneity of the product, it can be necessary to make measurements on different test specimens to determine the specific emission rate.

iTeh Standards
(<https://standards.iteh.ai>)
Document Preview

[ISO 16000-11:2024](https://standards.iteh.ai/catalog/standards/iso/43e0297d-7fd5-4c10-a20c-1912030a15c7/iso-16000-11-2024)

<https://standards.iteh.ai/catalog/standards/iso/43e0297d-7fd5-4c10-a20c-1912030a15c7/iso-16000-11-2024>

Indoor air —

Part 11:

Determination of the emission of volatile organic compounds from samples of building products and furnishing — Sampling, storage of samples and preparation of test specimens

1 Scope

This document specifies the sampling procedures, transport conditions, storage and substrate used that can affect emissions of volatile organic compounds for three types of building products or furnishing: solid, liquid and combined. For individual products, the preparation of a test specimen for each type is specified.

2 Normative references

The following documents are referred to in the text in such a way that some or all of their content constitutes requirements of this document. For dated references, only the edition cited applies. For undated references, the latest edition of the referenced document (including any amendments) applies.

ISO 16000-9:2024, *Indoor air — Part 9: Determination of the emission of volatile organic compounds from building products and furnishing — Emission test chamber method*

ISO 16000-10, *Indoor air — Part 10: Determination of the emission of volatile organic compounds from building products and furnishing — Emission test cell method*

EN 1937, *Test method for hydraulic setting floor smoothing and/or levelling compounds — Standard mixing procedures*

EN 13892-1, *Methods of test for screed materials — Part 1: Sampling, making and curing specimens for test*

3 Terms and definitions

For the purposes of this document, the following terms and definitions apply.

ISO and IEC maintain terminology databases for use in standardization at the following addresses:

— ISO Online browsing platform: available at <https://www.iso.org/obp>

— IEC Electropedia: available at <https://www.electropedia.org/>

3.1

solid product

<building product or furnishing> resilient or rigid product whose properties meet user-specifications directly without a transition phase, e.g. curing or drying

EXAMPLE 1 Examples of resilient products are several insulation products, flexible flooring and wall coverings.

EXAMPLE 2 Examples of rigid products are tiles, parquets, laminated floorings, wall construction products, such as chip- and gypsum boards, wood panels, ceiling materials, acoustic panels, and doors.

3.2

liquid product

<building product or furnishing> product whose properties meet the user-specifications after a transition phase, e.g. curing or drying

EXAMPLE Examples of liquid products are paints, varnishes, oils, waxes, levelling compounds, plasters, mortars, concrete, adhesives, sealants, caulks, putties, and surface coatings.

Note 1 to entry: Liquid products can have a wide range of viscosity and are supplied to the user in containers, such as cans, tubes, bottles, and sacks and are applied on the site.

Note 2 to entry: Some liquid products need the addition of water before they can be applied.

3.3

combined product

<building product or furnishing> product formed on-site by the combination of more than one *solid product* (3.1) or *liquid product* (3.2)

EXAMPLE Examples are glued applications such as floor and wall coverings that are fixed on the site on surfaces using adhesives.

Note 1 to entry: When liquid products as paints, oils and waxes are spread on an absorbing surface such as wood and gypsum board, the systems are considered to be combined.

4 Sampling the product and transport and storage of sample

4.1 Sampling of the product to be tested

Product samples collected at the point of manufacture shall be taken as soon as possible after the normal manufacturing process. The dates of sample manufacture and sample collection shall be recorded. Product samples can also be collected from retail stores.

NOTE An example of a sampling report is given in EN 16516^[1].

4.2 Sample packaging and transport

Samples shall be thoroughly protected from chemical contamination or any physical exposure, e.g. heat, light and humidity.

For solid products, this can usually be achieved by wrapping each specimen separately in aluminium foil and in a polyethylene bag or alternatively, in aluminised packaging lined with polyethylene or clear polyvinyl fluoride film. Liquid products shall be shipped in unopened cans, tubes, etc.

The product shall arrive in the laboratory within 14 days of sampling. If it takes longer than this, the time shall be recorded in the test report.

NOTE Transportation of collected samples can affect the emission characteristics of the product. The possible effects of temperature and humidity are of particular concern.

4.3 Sample description

The sample shall be labelled with the details of the type of product, week of manufacture (if known) and/or any identification numbers, such as the batch numbers, as specified in ISO 16000-9:2024, Clause 15 and ISO 16000-10.

4.4 Storage of the sample prior to starting the testing

In many cases, it can be necessary to store the sample in the laboratory before starting the test. The sample shall be kept in its package, see 4.2, and stored at normal indoor conditions during any period of storage.

ISO 16000-11:2024(en)

Storage can affect the emission properties due to ageing of the sample. It is recommended to minimize the storage time of the sample prior to preparation of the test specimen.

Testing shall begin within eight weeks of sampling provided that the sample remains in the specified packaging while stored at the laboratory. Wet-applied products that are shipped in a sealed container (e.g. can, cartridge) shall be tested within four months of sampling.

5 Preparation of test specimens

The dimensions of the test specimen depend on the selected test scenario and chamber size.

The preparation of test specimens of different product classes is prescribed in [Annexes A, B and C](#). The period of time between the unpacking and preparation of the test specimen shall be as short as possible and shall be recorded. After the completion of the test specimen, it shall be treated in accordance with ISO 16000-9.

NOTE 1 Some products (e.g. paint products) can require preconditioning prior to placing into a test chamber or emission cell.

NOTE 2 This document does not cover all types of construction materials and furnishings. Additional test methods for products are described in References [\[9\]](#), [\[10\]](#), [\[11\]](#) and [\[12\]](#).

The preparation of test specimens for the determination of emissions from cut edges is described in [Annex D](#).

iTeh Standards
(<https://standards.itih.ai>)
Document Preview

[ISO 16000-11:2024](#)

<https://standards.itih.ai/catalog/standards/iso/43e0297d-7fd5-4c10-a20c-1912030a15c7/iso-16000-11-2024>

Annex A
(informative)

Solid products — Procedure for sampling and test specimen preparation

A.1 General

This method covers only unused products.

A.2 Sampling

A.2.1 Selection of samples from rolls

See [Figure A.1](#).

Dimensions in metres

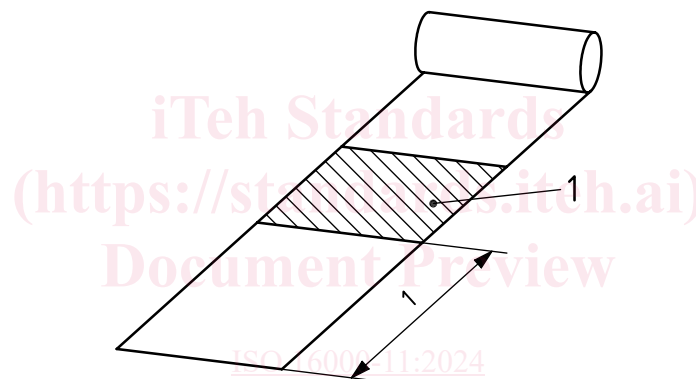

Key

1 sample

Figure A.1 — Procedure for sampling of solid products from rolls

Discard one metre, or at least the outer layer, of the roll to take the sample.

The sample shall have an area appropriate to the test chamber or cell.

After taking the sample, it is rolled across the direction of the production roll, secured with staples, wrapped in aluminium foil, and placed in an unprinted, airtight polyethylene bag and sealed. Each bag shall contain only one sample.

Not more than 1 h shall elapse from the time of taking the sample to packing it. The packed samples shall be sent to the testing laboratory with the shortest possible delay.

A.2.2 Selection of samples of rigid products

Send an unopened standard package or sales unit of the product to the testing laboratory.

Boards are transported in the normal manufacturer's delivery package unless the delivery package is large and impractical to handle. Then a sample may be taken from the middle of the board for more convenient transportation. In the latter case, the sample is packed according to [4.2](#).