



SLOVENSKI STANDARD
oSIST prEN 16922:2024
01-september-2024

Železniške naprave - Talna oskrba - Oprema vozil za odvoz odpadnih voda

Railway applications - Ground based services - Vehicle waste water discharge equipment

Bahnanwendungen - Versorgungsdienste - Fahrzeugabwasserentsorgungseinrichtungen

Applications ferroviaires - Services au sol - Equipement de vidange des eaux usées des véhicules

Ta slovenski standard je istoveten z: prEN 16922

[oSIST prEN 16922:2024](https://standards.iteh.ai/catalog/standards/sist/9bfc40ce-88ec-4633-bd83-f57070aacde0/osist-pren-16922-2024)

<https://standards.iteh.ai/catalog/standards/sist/9bfc40ce-88ec-4633-bd83-f57070aacde0/osist-pren-16922-2024>

ICS:

13.060.30	Odpadna voda	Sewage water
45.060.20	Železniški vagoni	Trailing stock

oSIST prEN 16922:2024

en,fr,de

EUROPEAN STANDARD
NORME EUROPÉENNE
EUROPÄISCHE NORM

DRAFT
prEN 16922

June 2024

ICS

Will supersede EN 16922:2017+A1:2019

English Version

Railway applications - Ground based services - Vehicle waste water discharge equipment

Applications ferroviaires - Services au sol - Equipement
de vidange des eaux usées des véhicules

Bahnanwendungen - Versorgungsdienste -
Fahrzeugabwasserentsorgungseinrichtungen

This draft European Standard is submitted to CEN members for enquiry. It has been drawn up by the Technical Committee CEN/TC 256.

If this draft becomes a European Standard, CEN members are bound to comply with the CEN/CENELEC Internal Regulations which stipulate the conditions for giving this European Standard the status of a national standard without any alteration.

This draft European Standard was established by CEN in three official versions (English, French, German). A version in any other language made by translation under the responsibility of a CEN member into its own language and notified to the CEN-CENELEC Management Centre has the same status as the official versions.

CEN members are the national standards bodies of Austria, Belgium, Bulgaria, Croatia, Cyprus, Czech Republic, Denmark, Estonia, Finland, France, Germany, Greece, Hungary, Iceland, Ireland, Italy, Latvia, Lithuania, Luxembourg, Malta, Netherlands, Norway, Poland, Portugal, Republic of North Macedonia, Romania, Serbia, Slovakia, Slovenia, Spain, Sweden, Switzerland, Türkiye and United Kingdom.

Recipients of this draft are invited to submit, with their comments, notification of any relevant patent rights of which they are aware and to provide supporting documentation.

Warning : This document is not a European Standard. It is distributed for review and comments. It is subject to change without notice and shall not be referred to as a European Standard.

<https://standards.iteh.ai/catalog/standards/sist/9bfc40ce-88ec-4633-bd83-f57070aacde0/osist-pren-16922-2024>



EUROPEAN COMMITTEE FOR STANDARDIZATION
COMITÉ EUROPÉEN DE NORMALISATION
EUROPÄISCHES KOMITEE FÜR NORMUNG

CEN-CENELEC Management Centre: Rue de la Science 23, B-1040 Brussels

Contents	Page
European foreword	3
1 Scope	4
2 Normative references	4
3 Terms and definitions	4
4 General	5
4.1 Description of vacuum	5
4.2 Description of controlled emission toilet systems	5
5 Requirements	5
5.1 General requirements.....	5
5.2 Vehicle requirements.....	7
5.2.1 Connections.....	7
5.2.2 System design.....	10
5.2.3 Temperature of operation.....	11
5.2.4 Pipework.....	11
5.2.5 Retention tank	12
5.2.6 Venting system.....	14
5.2.7 Sink waste.....	15
5.2.8 Test for leakage	15
5.3 Infrastructure requirements.....	15
5.3.1 General.....	15
5.3.2 System design.....	15
5.3.3 Connection.....	15
5.3.4 Flushing.....	16
5.3.5 Breakaway coupling	16
5.3.6 Pipework.....	16
5.3.7 Chemical storage.....	16
5.4 Information and instruction	16
5.4.1 For railway vehicles.....	16
5.4.2 For fixed installations (this includes mobile ground based installations)	16
Annex A (informative) Generic types of toilet retention systems	17
Bibliography	21

European foreword

This document (prEN 16922:2024) has been prepared by Technical Committee CEN/TC 256 “Railway applications”, the secretariat of which is held by DIN.

This document is currently submitted to the CEN Enquiry.

This document will supersede EN 16922:2017+A1:2019.

This document includes the following significant changes with respect to EN 16922:2017+A1:2019:

- 5.2.8 is revised to give additional guidance to not over pressurize the system;
- update of standard references.

iTeh Standards
(<https://standards.iteh.ai>)
Document Preview

[oSIST prEN 16922:2024](https://standards.iteh.ai/catalog/standards/sist/9bfc40ce-88ec-4633-bd83-f57070aacde0/osist-pren-16922-2024)

<https://standards.iteh.ai/catalog/standards/sist/9bfc40ce-88ec-4633-bd83-f57070aacde0/osist-pren-16922-2024>

prEN 16922:2024 (E)**1 Scope**

This document specifies the interface requirements for controlled emission toilet equipment on railway vehicles and the infrastructure, including catering area sink waste retention tanks. Vehicle and infrastructure specific requirements are also given.

The document includes fixed and portable infrastructure equipment used to empty retention tanks, but excludes equipment fitted to railway vehicles where no fixed connections are used between vehicle and infrastructure.

2 Normative references

The following documents, in whole or in part, are normatively referenced in this document and are indispensable for its application. For dated references, only the edition cited applies. For undated references, the latest edition of the referenced document (including any amendments) applies.

EN 1717:2000, *Protection against pollution of potable water in water installations and general requirements of devices to prevent pollution by backflow*

EN 12663-1:2010+A2:2023, *Railway applications - Structural requirements of railway vehicle bodies - Part 1: Locomotives and passenger rolling stock (and alternative method for freight wagons)*

EN 15877-2:2013, *Railway applications - Markings of railway vehicles - Part 2: External markings on coaches, motive power units, locomotives and on track machines*

EN 16362:2013, *Railway applications - Ground based services - Water restocking equipment*

EN 45545-2:2020+A1:2023, *Railway applications - Fire protection on railway vehicles - Part 2: Requirements for fire behaviour of materials and components*

3 Terms and definitions

For the purposes of this document, the following terms and definitions apply

ISO and IEC maintain terminology databases for use in standardization at the following addresses:

— ISO Online browsing platform: available at <https://www.iso.org/obp/>

— IEC Electropedia: available at <https://www.electropedia.org/>

3.1**railway infrastructure**

all installations required for the running of railway vehicles including operating and support facilities

EXAMPLE Tracks, crossings, catenaries, signals, maintenance depots.

3.2**grey water**

waste water from hand wash and galley sinks, usually contaminated with soap, germicides, residues of food, drink and dish water

3.3**servicing point**

location where maintenance, refuelling and cleaning is carried out

3.4

controlled emission toilet

toilet system where the toilet waste is retained on the vehicle and emptied at prescribed locations, including on board waste treatment systems which are permitted to discharge some wastes at various locations

4 General

4.1 Description of vacuum

Vacuum can be expressed in different manners. Absolute vacuum is 0 bar and atmospheric pressure is nominally 1 bar (although this varies). When a vacuum pump evacuates 0,2 bar from a tank the remaining pressure within the tank is 0,8 bar (if the atmospheric pressure is 1 bar), but this can be expressed in a variety of ways. Therefore, to avoid doubt, because the atmospheric pressure varies, throughout this standard vacuum is expressed as a negative number of bars below atmosphere (i.e. in the above example this is expressed within this standard as -0,2 bar).

Positive pressure is expressed as bars above atmosphere, i.e. in this standard an absolute pressure of 3 bar is shown as +2 bar.

4.2 Description of controlled emission toilet systems

There are five generic types of controlled emission toilets fitted to railway vehicles considered in this document, shown diagrammatically in Annex A.

5 Requirements

5.1 General requirements

Each vehicle and servicing point shall be clearly marked with the type of system that is fitted, or intended to be used for. Adjacent to the connection on the vehicle and infrastructure the background, or if there is no background, an area beside the connection with a minimum dimension 60 mm x 60 mm, shall be coloured as shown in Table 1 and marked with the wording shown in Table 1 in the native language of the servicing point or the home depot of the vehicle and also at least in English. The labels shall be in a contrasting colour to the background colour.

<https://standards.iteh.ai/> <https://standards.iteh.ai/document/preview/40ce-88ec-4633-bd83-f57070aacde0/osist-pren-16922-2024>

Table 1 — Identification of toilet system

Type of system	Background colour The size of background colour shall be at least 60 mm x 60 mm:	Wording of label beside 3" connection	Wording of label beside 1" connection	Wording of label beside high pressure water connection
Compact system	Green	Toilet discharge	Flushing pipe	Not applicable
On line vacuum	Green	Toilet discharge	Flushing pipe	Not applicable
Permanent vacuum	Red	Toilet discharge, ensure ventilation is open	Flushing pipe	Not applicable
Chemical	Blue	Chemical toilet discharge	Flushing and chemical addition	Not applicable
On board waste treatment (e.g. bioreactor)	Yellow	On board waste treatment toilet discharge and cleaning	On board waste treatment water inlet and suction	On board waste treatment high pressure water
Catering area sink waste retention	Grey	Catering area sink waste	Not applicable	Not applicable

The position on a vehicle of the background colour and labels described in Table 1 is shown diagrammatically in Figure 1.

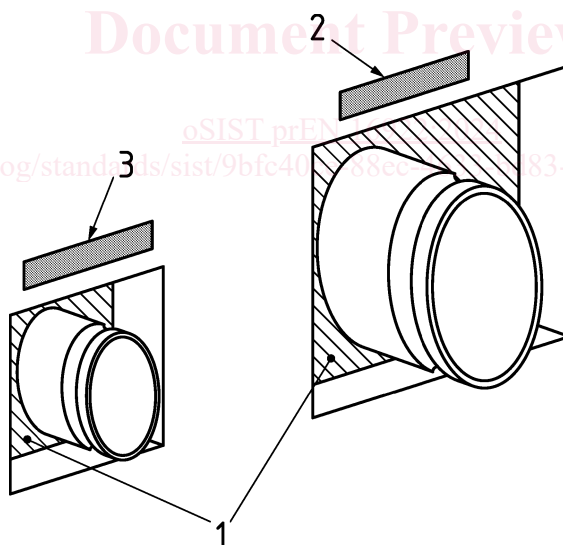
**Key**

- 1 background colour of type of system (as shown in Table 1)
- 2 label beside 3" connection
- 3 label beside 1" connection

Figure 1 — Identification of connections on vehicle

On the label shown in Figure 1, Key 2, the volume of the retention tank in litres shall be indicated.

5.2 Vehicle requirements

5.2.1 Connections

Except for vehicles fitted with on board waste treatment system each vehicle with toilet waste or catering area sink waste retention tank shall be fitted with a connection as shown in Figure 2 on each side of vehicle. Vehicles fitted with on board waste treatment system are permitted to have the 3" connection on one side, but it is preferable to have on both sides.

For toilet waste retention tanks each such vehicle, excluding locomotives, shall also be fitted with a flushing connection as shown in Figure 3. On vehicles fitted with a chemical toilet system (Annex A, Figure A.4) the flushing connection shall be fitted on each side of the vehicle, for all other toilet systems the flushing connection shall be as a minimum of one side of the vehicle.

As design guidance it is preferable to have the flushing connection on both sides. It is also preferable to fit flushing connections for catering area sink waste tanks. Provision of the flushing connection reduces maintenance costs and increases efficiency of cleaning operations of the tank.

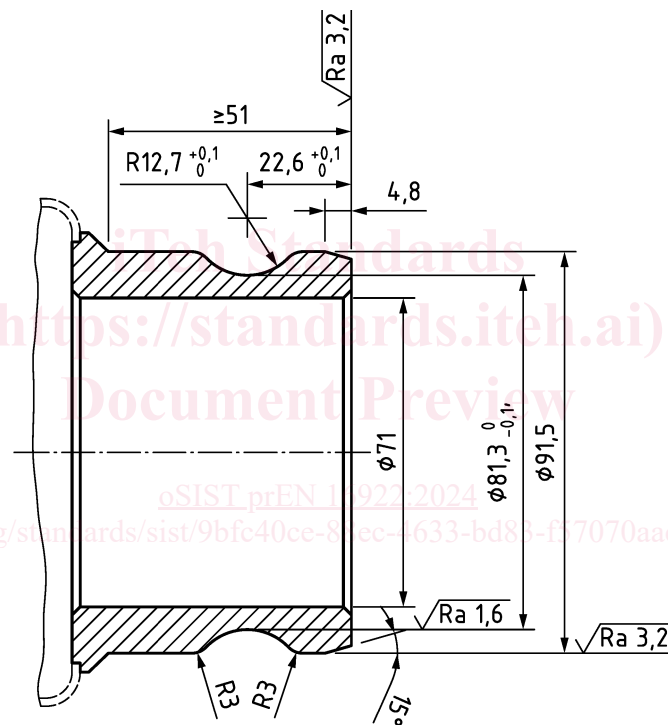

NOTE 1 General tolerances $\pm 0,1$.

NOTE 2 Material: stainless steel.

Figure 2 — 3" connection (inner part)

prEN 16922:2024 (E)

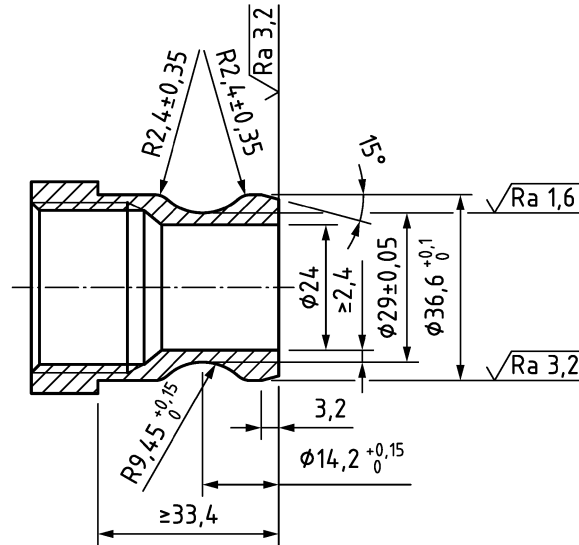

NOTE 1 General tolerances $\pm 0,1$.

NOTE 2 Material: stainless steel.

Figure 3 — 1" connection (inner part)

The connections on the vehicle shall be between 500 mm and 1 500 mm above rail level, measured to the centre of the connection. They shall not be recessed further than 100 mm deeper than the vehicle bodyline. Where the connections are set back from the vehicle bodyline contained within a box structure, the floor of the box shall be sloping outwards so that water cannot be retained in the enclosed box and always drains to the outside of the vehicle. The connections shall have space around them as detailed in Figure 4 and Figure 5 to allow connection of the pipe – this does not have to be all the way around the connection but shall be for the direction the pipe connection rotates (i.e. the space around connection does not have to be circular but is permitted to be rectangular or oval). When a manual valve is included in the connection area, the space around the connection shall permit the opening and closing operations.

[oSIST prEN 16922:2024](https://standards.iteh.ai/catalog/standards/sist/9bfc40ce-88ec-4633-bd83-f57070aacde0/osist-pren-16922-2024)

<https://standards.iteh.ai/catalog/standards/sist/9bfc40ce-88ec-4633-bd83-f57070aacde0/osist-pren-16922-2024>