



Designation: D1830 – 99 (Reapproved 2012)

Standard Test Method for Thermal Endurance of Flexible Sheet Materials Used for Electrical Insulation by the Curved Electrode Method¹

This standard is issued under the fixed designation D1830; the number immediately following the designation indicates the year of original adoption or, in the case of revision, the year of last revision. A number in parentheses indicates the year of last reapproval. A superscript epsilon (ϵ) indicates an editorial change since the last revision or reapproval.

This standard has been approved for use by agencies of the U.S. Department of Defense.

1. Scope

1.1 This test method provides a procedure for evaluating thermal endurance of flexible sheet materials by determining dielectric breakdown voltage at room temperature after aging in air at selected elevated temperatures. Thermal endurance is expressed in terms of a temperature index.

1.2 This test method is applicable to such solid electrical insulating materials as coated fabrics, dielectric films, composite laminates, and other materials where retention of flexibility after heat aging is of major importance (see **Note 4**).

1.3 This test method is not intended for the evaluation of rigid laminate materials nor for the determination of thermal endurance of those materials which are not expected or required to retain flexibility in actual service.

1.4 The values stated in acceptable metric units are to be regarded as the standard. The values in parentheses are for information only.

1.5 *This standard does not purport to address all of the safety concerns, if any, associated with its use. It is the responsibility of the user of this standard to establish appropriate safety and health practices and determine the applicability of regulatory limitations prior to use.* For a specific hazard statement, see **10.1**.

2. Referenced Documents

2.1 ASTM Standards:²

- D149** Test Method for Dielectric Breakdown Voltage and Dielectric Strength of Solid Electrical Insulating Materials at Commercial Power Frequencies
- D374** Test Methods for Thickness of Solid Electrical Insulation (Metric) D0374_D0374M
- D5423** Specification for Forced-Convection Laboratory Ovens for Evaluation of Electrical Insulation

2.2 Institute of Electrical and Electronics Engineers Publications:³

- IEEE No. 1** General Principles for Temperature Limits in the Rating of Electrical Equipment
- IEEE No. 101A** Guide for the Statistical Analysis of Thermal Life Test Data (including Appendix A)

2.3 IEC Publications:

- IEC 216** Guide for the Determination of Thermal Endurance Properties of Electrical Insulating Materials (Parts 1 and 2)⁴

3. Terminology

3.1 Definitions:

3.1.1 *temperature index, n*—a number which permits comparison of the temperature/time characteristics of an electrical insulating material, or a simple combination of materials, based on the temperature in degrees Celsius which is obtained by extrapolating the Arrhenius plot of life versus temperature to a specified time, usually 20 000 h.

3.1.2 *thermal life, n*—the time necessary for a specific property of a material, or simple combination of materials, to degrade to a defined end point when aged at a specific temperature.

3.1.3 *thermal life curve, n*—a graphical representation of thermal life at a specified aging temperature in which the value of a property of a material, or a simple combination of materials, is measured at room temperature and the values plotted as a function of time.

3.2 Definitions of Terms Specific to This Standard:

3.2.1 *thermal endurance graph*—a straight-line plot of the logarithm of thermal life in hours versus the reciprocal of the absolute aging temperature in kelvins (also known as the Arrhenius plot).

¹ This test method is under the jurisdiction of ASTM Committee D09 on Electrical and Electronic Insulating Materials and is the direct responsibility of Subcommittee D09.01 on Electrical Insulating Products

Current edition approved Jan. 1, 2012. Published January 2012. Originally approved in 1961. Last previous edition approved in 2005 as D1830 – 99 (2005). DOI: 10.1520/D1830-99R12.

² For referenced ASTM standards, visit the ASTM website, www.astm.org, or contact ASTM Customer Service at service@astm.org. For *Annual Book of ASTM Standards* volume information, refer to the standard's Document Summary page on the ASTM website.

³ Available from Institute of Electrical and Electronics Engineers, Inc. (IEEE), 445 Hoes Ln., P.O. Box 1331, Piscataway, NJ 08854-1331.

⁴ Available from American National Standards Institute (ANSI), 25 W. 43rd St., 4th Floor, New York, NY 10036.

4. Summary of Test Method

4.1 Specimens are aged in air at a minimum of three temperatures above the expected use temperature of the material. Dielectric breakdown voltage tests in air at room temperature are periodically made to determine the time of aging at each test temperature required to reduce the breakdown voltage to a value of 12 kV/mm (300 V/mil) of original thickness. These thermal life values are used to construct a thermal endurance graph by means of which temperature indices may be estimated corresponding to a thermal life as specified in the material specification or as agreed upon between the user and the supplier.

NOTE 1—This test method is not applicable to materials having an initial dielectric breakdown voltage of less than 12 kV/mm (300 V/mil) of original thickness unless lower endpoint values are agreed upon or indicated in the applicable material specifications.

5. Significance and Use

5.1 A major factor affecting the life of insulating materials is thermal degradation. Other factors, such as moisture and vibration, may cause failures after the material has been weakened by thermal degradation.

5.2 Electrical insulation is effective in electrical equipment only as long as it retains its physical and electrical integrity. Thermal degradation may be characterized by weight change, porosity, crazing, and generally a reduction in flexibility, and is usually accompanied by an ultimate reduction in dielectric breakdown voltage.

6. Apparatus

6.1 *Electrode Test Fixture*—The fixture shall be in accordance with the dimensions shown in Fig. 1 and Fig. 2. Electrodes shall be of polished brass, with the upper electrode having a mass of 1.8 ± 0.05 kg (4.0 ± 0.1 lb).

6.2 *Dielectric Breakdown Test Set*—The set shall meet the requirements of Test Method D149.

6.3 *Ovens*—Ovens shall meet the requirements of Specification D5423 Type II.

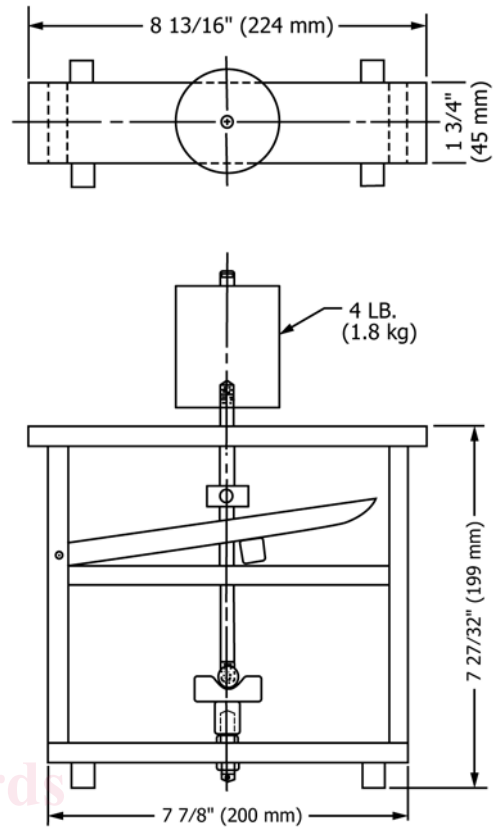
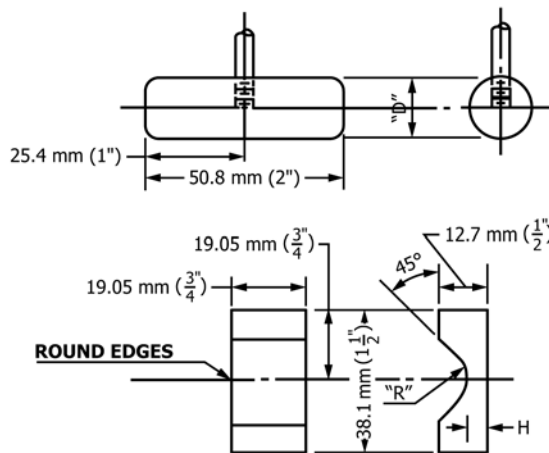

FIG. 2 Curved Electrode and Holder



Insulation Thickness		Dimension R		Dimension H		Dimension D	
mm	in.	mm	in.	mm	in.	mm	in.
0.18	0.007	4.55	0.179	8.15	0.321	8.71	0.344
0.25	0.010	6.48	0.255	6.22	0.245	2.45	0.490
0.30	0.012	7.77	0.306	4.93	0.194	4.94	0.588

Tolerance for R and D = ± 0.03 mm (0.001 in.)
 Tolerance for H = ± 0.05 mm (0.002 in.)

FIG. 1 Curved Electrode Details