



Designation: E2863 – 11

Standard Practice for Acoustic Emission Examination of Welded Steel Sphere Pressure Vessels Using Thermal Pressurization¹

This standard is issued under the fixed designation E2863; the number immediately following the designation indicates the year of original adoption or, in the case of revision, the year of last revision. A number in parentheses indicates the year of last reapproval. A superscript epsilon (ϵ) indicates an editorial change since the last revision or reapproval.

1. Scope

1.1 This practice is commonly used for periodic inspection and testing of welded steel gaseous spheres (bottles) is the acoustic emission (AE) method. AE is used in place of hydrostatic volumetric expansion testing. The periodic inspection and testing of bottles by AE testing is achieved without depressurization or contamination as is required for hydrostatic volumetric expansion testing.

1.2 The required test pressurization is achieved by heating the bottle in an industrial oven designed for this purpose. The maximum temperature needed to achieve the AE test pressure is $\leq 250^{\circ}\text{F}$ (121°C).

1.3 AE monitoring of the bottle is performed with multiple sensors during the thermal pressurization.

1.4 This practice was developed for periodic inspection and testing of pressure vessels containing Halon (UN 1044), which is commonly used aboard commercial aircraft for fire suppression. In commercial aircraft, these bottles are hermetically sealed by welding in the fill port. Exit ports are opened by explosively activated burst disks. The usage of these pressure vessels in transportation is regulated under US Department of Transportation (DOT), Code of Federal Regulations CFR 49. A DOT special permit authorizes the use of AE testing for periodic inspection and testing in place of volumetric expansion and visual inspection. These bottles are spherical with diameters ranging from 5 to 16 in. (127 to 406 mm).

1.5 The values stated in inch-pound units are to be regarded as the standard. The values given in parentheses are mathematical conversions to SI units that are provided for information only and are not considered standard.

1.6 *This standard does not purport to address all of the safety concerns, if any, associated with its use. It is the responsibility of the user of this standard to establish appropriate safety and health practices and determine the applicability of regulatory limitations prior to use.* Specific precautionary statements are given in Section 8.

¹ This practice is under the jurisdiction of ASTM Committee E07 on Nondestructive Testing and is the direct responsibility of Subcommittee E07.04 on Acoustic Emission Method.

Current edition approved Dec. 15, 2011. Published January 2012. DOI:10.1520/E2863-11.

2. Referenced Documents

2.1 ASTM Standards:²

E543 Specification for Agencies Performing Nondestructive Testing

E650 Guide for Mounting Piezoelectric Acoustic Emission Sensors

E976 Guide for Determining the Reproducibility of Acoustic Emission Sensor Response

E1316 Terminology for Nondestructive Examinations

E2075 Practice for Verifying the Consistency of AE-Sensor Response Using an Acrylic Rod

E2374 Guide for Acoustic Emission System Performance Verification

2.2 ASNT Standards:³

SNT-TC-1A Recommended Practice for Nondestructive Testing Personnel Qualification and Certification

ANSI/ASNT CP-189 Standard for Qualification and Certification of Nondestructive Testing Personnel

2.3 Code of Federal Regulations:

Section 49 Code of Federal Regulations, Hazardous Materials Regulations of the Department of Transportation, Paragraphs 173.34, 173.301, 178.36, 178.37, and 178.45⁴

2.4 Compressed Gas Association Standard:

Pamphlet C-5 Service Life, Seamless High Pressure Cylinders⁵

3. Terminology

3.1 *Definitions*—See Terminology E1316 for general terminology applicable to this test method.

3.2 Definitions of Terms Specific to This Standard:

3.2.1 *marked service pressure*—pressure for which a vessel is rated. Normally, this value is stamped on the vessel

² For referenced ASTM standards, visit the ASTM website, www.astm.org, or contact ASTM Customer Service at service@astm.org. For *Annual Book of ASTM Standards* volume information, refer to the standard's Document Summary page on the ASTM website.

³ Available from American Society for Nondestructive Testing (ASNT), P.O. Box 28518, 1711 Arlingate Ln., Columbus, OH 43228-0518, http://www.asnt.org.

⁴ Available from U.S. Government Printing Office Superintendent of Documents, 732 N. Capitol St., NW, Mail Stop: SDE, Washington, DC 20401, http://www.access.gpo.gov.

⁵ Available from Compressed Gas Association (CGA), 4221 Walney Rd., 5th Floor, Chantilly, VA 20151-2923, http://www.cganet.com.

4. Summary of Practice

4.1 Acoustic emission (AE) sensors are mounted on a pressure vessel, and emission is monitored while the pressure vessel is heated to a pre-determined temperature for achieving the desired AE test pressure. The elevated temperature results in expansion of the gaseous component and causes the increase of the internal pressure. This increasing pressure applies stress in the pressure vessel wall. The ultimate pressure is calculated based on the contents of the pressure vessel (bottle) and maximum operating temperature that bottle has been exposed (for example, during fast filling).

4.2 Sensors are mounted in at least six positions on the vessel and are connected to an acoustic emission signal processor. The signal processor uses measured times of arrival of emission bursts to determine the location of emission sources on the vessels surface. The locations are continually checked for clustering. If a cluster grows large enough (refer to [Appendix X1](#)), and/or its behavior with increasing temperature (pressure) departs significantly from a linear increase (refer to [Appendix X1](#)), the vessel is declared unsatisfactory for continued service.

4.3 Bottles that fail this AE examination procedure cannot be subjected to a secondary examination (for example, hydrostatic volumetric expansion test) because the AE test is the more sensitive test. When a bottle has been rejected by an AE test, it should be rendered unserviceable.

4.4 To repeat a valid AE examination on a bottle, a minimum of six months interval shall be required to the bottle after its highest previous internal pressure.

5. Significance and Use

5.1 Because of safety considerations, regulatory agencies (for example, U.S. Department of Transportation) require periodic tests of pressurized vessels used in commercial aviation. (see [Section 49](#), Code of Federal Regulations). AE testing has become accepted as an alternative to the common hydrostatic proof test.

5.2 An AE test should not be conducted for a period of one year after a common hydrostatic test. See [Note 1](#).

NOTE 1—The Kaiser effect relates to the irreversibility of acoustic emission which results in decreased emission during a second pressurization. Common hydrostatic tests use a relatively high test pressure (200 % of normal service pressure). (See [Section 49](#), Code of Federal Regulations.) If an AE test is performed too soon after such a hydrostatic pressurization, the AE results will be insensitive below the previous maximum test pressure.

5.3 Acoustic Emission is produced when an increasing stress level in a material causes crack growth in the material or stress related effects in a corroded surface (for example, crack growth in or between metal crystallites or spalling and cracking of oxides and other corrosion products).

5.4 While background noise may distort AE data or render it useless, heating the vessels inside an industrial oven is an almost noise free method of pressurization. Further, source location algorithms using over-determined data sets will often allow valid tests in the presence of otherwise interfering noise sources. Background noise should be reduced or controlled but the sudden occurrence of such noise does not necessarily invalidate a test.

6. Basis of Application

6.1 The following items are subject to contractual agreement between the parties using or referencing this standard.

6.2 Personnel Qualification:

6.2.1 If specified in the contractual agreement, personnel performing examinations to this standard shall be qualified in accordance with a nationally or internationally recognized NDT personnel qualification practice or standard such as ANSI/ASNT-CP-189, [SNT-TC-1A](#), NAS-410, or a similar documented and certified by the employer or certifying agency, as applicable. The practice or standard used and its applicable revision shall be identified in the contractual agreement between the using parties.

6.2.2 The NDT personnel shall be qualified in accordance with a nationally recognized NDT personnel qualification practice or standard such as [ANSI/ASNT CP-189](#), [SNT-TC-1A](#), or a similar document. The practice or standard used and its applicable revision shall be specified in the contractual agreement between the using parties.

6.3 *Qualification of Nondestructive Testing Agencies*—If specified in the contractual agreement, NDT agencies shall be qualified and evaluated as described in Specification [E543](#). The applicable edition of Specification [E543](#) shall be specified in the contractual agreement.

6.4 *Procedures and Techniques*—The procedures and techniques to be utilized shall be as specified in the contractual agreement.

6.5 *Surface Preparation*—The pre-examination surface repair criteria shall be in accordance with [10.2.1](#), unless otherwise specified.

6.6 *Reporting Criteria/Acceptance Criteria*—Reporting criteria for the examination results shall be in accordance with [Appendix X1](#) unless otherwise specified.

7. Apparatus

7.1 Essential features of the apparatus required for this practice are provided in [Fig. 1](#). Full specifications are in [Annex A1](#).

7.2 A couplant can be used between the sensors and vessel wall. The small diameter of the sensor and significant contact pressure reduces the requirement for a couplant, but it is often useful when positioning a vessel in the test frame to avoid interfering features on its surface or when the first AST coupling test has failed.

7.3 AE Sensors are held in place by means of spring-loaded rods mounted to the test frame.

7.4 The AE sensors are continuously monitored throughout the pressurization.

7.5 A preamplifier for each sensor is located outside the oven. The sensor cable length must not exceed 6 ft (2 m).

7.6 The signal processor is a computerized instrument with independent channels that filter, measure, and convert analog information into digital form for analysis, display and permanent storage. A signal processor must have sufficient speed and capacity to independently process data from all sensors simultaneously. The signal processor must be programmed to locate the sources on the surfaces of the vessel and to detect clustering of the sources. The instrument must be capable of reading the

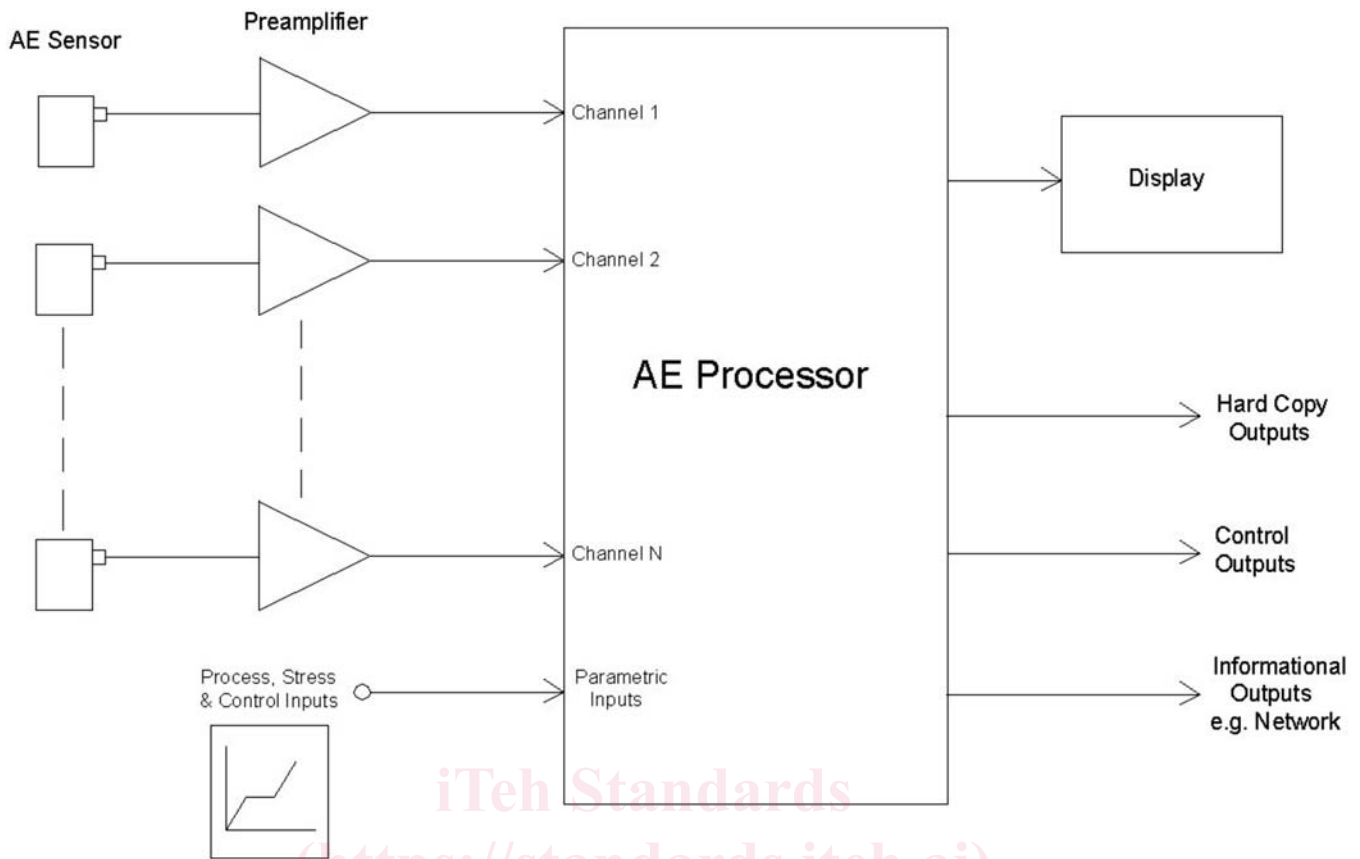

FIG. 1 AE System Block Diagram

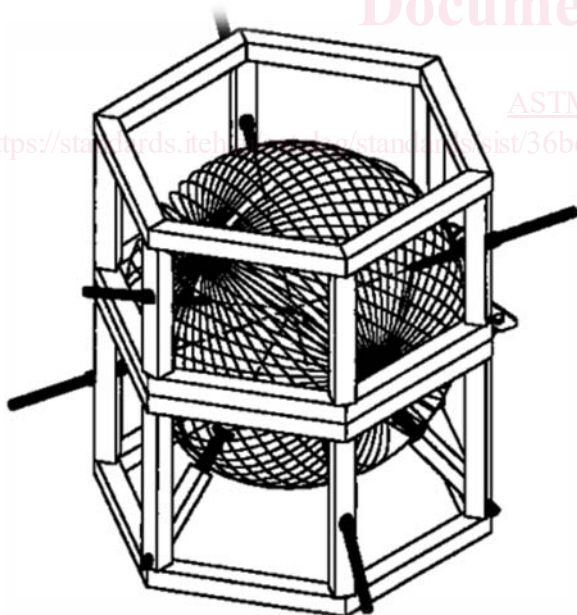

FIG. 2 AE Sensor Holding Fixture (sensors on the head of the spring loaded rods)

8. Safety Precautions

8.1 This examination involves pressurization of sealed vessels by heating. When a significant defect is detected, there is no method of decreasing the internal pressure except cooling of the vessel. It is imperative that the heating cease as soon as a significant defect is identified. This requires that the AE system have complete control over the examination, including the pre and post-examination system performance verification; the oven heaters; detecting, identifying and classifying defects and the determination of when the defect behavior requires the test to be stopped, decreasing the possibility of an explosion. The operator has no control over the carrying out of the test, including analysis and grading of defects or when to stop the test for safety reasons.

8.2 Maximum temperature of the oven's heating element surface must remain below 800°F (427°C). This will prevent thermal decomposition of the HALON 1301 into toxic byproducts in the event of an accidental release.

8.3 HALON 1301, itself, has low toxicity but a rapid release of pressure could rupture the oven and/or present an asphyxiation hazard in a small enclosed region.

9. Calibration and Verification

9.1 Annual calibration and verification of AE sensors, preamplifiers, signal processor (particularly the signal processor time reference), and AE electronic waveform generator, should be performed. Equipment should be adjusted so that it

vessel temperature and controlling the industrial oven. It must also conduct and interpret AST tests both before and after the thermal pressurization.

7.6.1 Hard copy capability should be available from a printer or equivalent device.