



Standard Test Method for Absorption Coefficient of Ethylene Polymer Material Pigmented with Carbon Black¹

This standard is issued under the fixed designation D3349; the number immediately following the designation indicates the year of original adoption or, in the case of revision, the year of last revision. A number in parentheses indicates the year of last reapproval. A superscript epsilon (ϵ) indicates an editorial change since the last revision or reapproval.

1. Scope*

- 1.1 This test method measures the amount of light transmitted through a film of carbon black pigmented ethylene polymer.
- 1.2 After calculation of the amount of light and film thickness, an absorption coefficient is calculated.
- 1.3 Whenever two sets of values are presented, in different units, the values in the first set are the standard, while those in parentheses are for information only.
- 1.4 *This standard does not purport to address all of the safety concerns, if any, associated with its use. It is the responsibility of the user of this standard to establish appropriate safety and health practices and determine the applicability of regulatory limitations prior to use.*

2. Referenced Documents

- 2.1 *ASTM Standards*:²
 - E60 Practice for Analysis of Metals, Ores, and Related Materials by Spectrophotometry
 - D1248 Specification for Polyethylene Plastics Extrusion Materials for Wire and Cable

3. Summary of Test Method

3.1 The transmission of light of a specified wavelength through thin ethylene polymer film is measured. The result is used to calculate an absorption coefficient that is a reciprocal function of transmission after correction for thickness.

4. Significance and Use

4.1 The absorption coefficient of polyolefin polymer pigmented with carbon black is useful to judge the degree and uniformity of dispersion of the pigment, and the adequacy of the quantitative level of pigment addition. These factors are used to predict the performance of the polymer material in response to prolonged exposure to ultraviolet light as evidenced by minimal changes in specific properties.

NOTE 1—This test method was developed to evaluate ethylene polymer materials pigmented with small particle size carbon blacks suitable for UV protection. It is not known how accurate and reproducible the test would be with larger (35 nm or greater) particle size blacks.

5. Apparatus

5.1 *Spectrophotometer*—An instrument in accordance with Practice E60 is required.

NOTE 2—Consult the spectrophotometer's operation manual or consult the manufacturer of the instrument for the calibration procedure.

5.2 *Mold*—A mold in accordance with Figs. 1 and 2. Make the mold of Ketos steel (or equivalent) hardened to Rockwell C45, with mold surfaces chromium plated to 0.005-mm (0.0002-in.) minimum thickness.

5.3 *Specimen Holder*—Cut two concentric rings from phenolic-paper laminate or other suitable material to the dimensions shown in Fig. 3. Slip fit the rings snugly one within the other.

5.4 *Reference Material*—A reference material is required having an absorbance value of 1.0 to 1.2 at 375 nm as measured by the instrument used for testing.

¹ This test method is under the jurisdiction of ASTM Committee D09 on Electrical and Electronic Insulating Materials and is the direct responsibility of Subcommittee D09.18 on Solid Insulations, Non-Metallic Shieldings, and Coverings for Electrical and Telecommunications Wires and Cables.

Current edition approved April 1, 2006/2012. Published April 2006/February 2012. Originally approved in 1974. Last previous edition approved in 1999/2006 as D3349-99/D3349-06. DOI: 10.1520/D3349-06; 10.1520/D3349-12.

² For referenced ASTM standards, visit the ASTM website, www.astm.org, or contact ASTM Customer Service at service@astm.org. For *Annual Book of ASTM Standards* volume information, refer to the standard's Document Summary page on the ASTM website.

*A Summary of Changes section appears at the end of this standard.

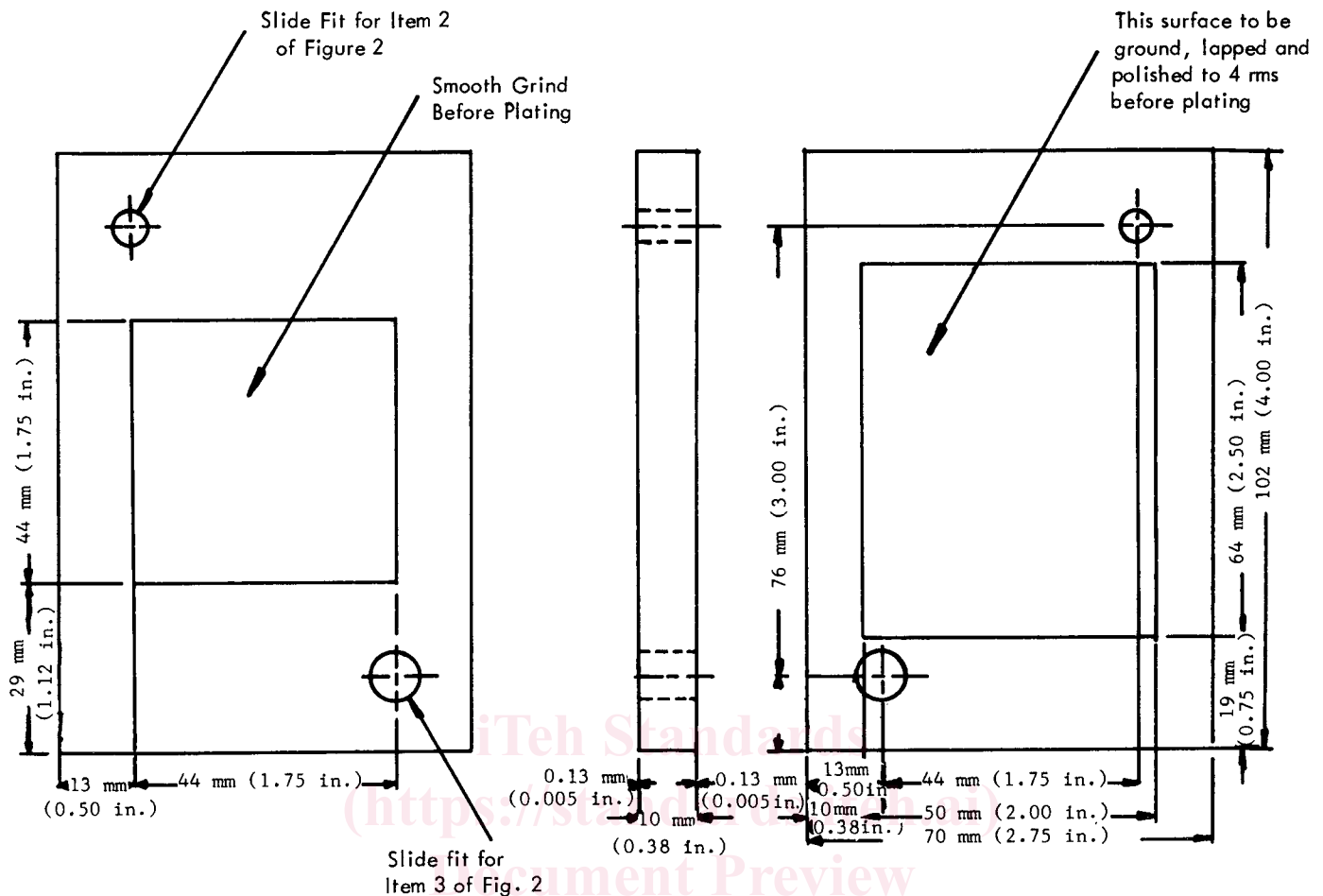

FIG. 1 Mold, Top Platen

5.4.1 *Neutral Density Filter*,³ M-type carbon 0.85 density, laminated between cellulose acetate sheets has been found satisfactory. Since this material is furnished as a rigid sheet, it cannot be mounted as described in Section 7. Instead, a special mount must be prepared by cutting Ring 1 of Fig. 3 in half around its circumference to give two rings about 2 mm (0.08 in.) thick. Cut a 22-mm (0.87-in.) circle from the laminated filter, sandwich this between the two 2-mm rings, and slide the outer ring (Ring 2 of Fig. 3) over this composite.

5.4.2 An alternative reference material can be prepared by any user of this test method. Prepare an alternative reference material consisting of a highly uniform sample of ASTM Type I polyethylene (see Specification D1248) containing about 1 % of a 20-nm carbon black (either channel or furnace type). Press out a uniform film of this material and mount as in Section 8 to meet the above requirements. Reference materials so prepared shall show no more than ± 4 % variation from the average absorbance value when measured at any point at 375 nm in the instrument used for testing.

6. Calibration and Standardization

6.1 Allow the spectrophotometer to stabilize. Using the spectrophotometer manufacturer's instructions, set the zero and infinity values on the absorbance scale.

6.2 Insert the mounted reference material in the spectrophotometer and place it into the light beam. Read and record the absorbance value using the conditions that bring the value nearest to zero on the absorbance scale. With the reference material still in the beam, readjust the slit width to bring the reading back to zero. Recheck the infinity value.

7. Conditioning

7.1 No special conditioning is required.

8. Specimen Preparation

8.1 Prepare three test specimens from each lot of material by hot-pressing the ethylene polymer at a suitable temperature

³ The sole source of supply of the apparatus known to the committee at this time is The Kodak neutral density filter, No. 5, available from the Eastman Kodak Co.. If you are aware of alternative suppliers, please provide this information to ASTM International Headquarters. Your comments will receive careful consideration at a meeting of the responsible technical committee, which you may attend.