



Designation: D3638 – 12

# Standard Test Method for Comparative Tracking Index of Electrical Insulating Materials<sup>1</sup>

This standard is issued under the fixed designation D3638; the number immediately following the designation indicates the year of original adoption or, in the case of revision, the year of last revision. A number in parentheses indicates the year of last reapproval. A superscript epsilon ( $\epsilon$ ) indicates an editorial change since the last revision or reapproval.

## 1. Scope\*

1.1 This test method evaluates in a short period of time the low-voltage (up to 600 V) track resistance or comparative tracking index (CTI) of materials in the presence of aqueous contaminants.

1.2 The values stated in metric (SI) units are to be regarded as standard. The inch-pound equivalents of the metric units are approximate.

1.3 This standard is technically equivalent to the version of IEC Publication 112 cited in 2.2. However, the 2007 version of IEC 60112 Fourth Edition yields numerical CTI values that are very likely to differ significantly from this standard.

1.4 *This standard does not purport to address all of the safety problems, if any, associated with its use. It is the responsibility of the user of this standard to establish appropriate safety and health practices and determine the applicability of regulatory limitations prior to use.*

## 2. Referenced Documents

2.1 *ASTM Standards:*<sup>2</sup>

[D1711 Terminology Relating to Electrical Insulation](#)  
[D6054 Practice for Conditioning Electrical Insulating Materials for Testing](#) (Withdrawn 2012)<sup>3</sup>

2.2 *IEC Publication:*

[112 Recommended Method for Determining the Comparative Track Index of Solid Insulating Materials Under Moist Conditions, 1971 Second Edition](#)<sup>4</sup>

[60112 Recommended Method for Determining the Comparative Track Index of Solid Insulating Materials Under](#)

[Moist Conditions, 2007 Fourth Edition](#)<sup>4</sup>

## 3. Terminology

3.1 *Definitions:*

3.1.1 *track*—a partially conducting path of localized deterioration on the surface of an insulating material.

3.1.2 *tracking*—the process that produces tracks as a result of the action of electric discharges on or close to an insulation surface.

3.1.3 *tracking, contamination*—tracking caused by scintillations that result from the increased surface conduction due to contamination.

3.1.4 *tracking resistance*—the quantitative expression of the voltage and the time required to develop a track under the specified conditions.

3.1.5 For other terminology, refer to Terminology [D1711](#).

3.2 *Definitions of Terms Specific to This Standard:*

3.2.1 *comparative tracking index*—an index for electrical insulating materials which is arbitrarily defined as the numerical value of that voltage which will cause failure by tracking when the number of drops of contaminant required to cause failure is equal to 50.

3.2.1.1 *Discussion*—The voltage value is obtained from a plot of the number of drops required to cause failure by tracking versus the applied voltage.

3.2.2 *failure, n*—an attribute of an electrical circuit containing an electrical-current-sensing device that rapidly decreases the applied voltage to zero if the current in the circuit exceeds a predetermined limit.

## 4. Summary of Test Method

4.1 The surface of a specimen of electrical insulating material is subjected to a low-voltage alternating stress combined with a low current which results from an aqueous contaminant (electrolyte) which is dropped between two opposing electrodes every 30 s. The voltage applied across these electrodes is maintained until the current between them exceeds a predetermined value. This condition constitutes a failure. Additional specimens are tested at other voltages so that a relationship between applied voltage and number of drops to failure can be established through graphical means.

<sup>1</sup> This test method is under the jurisdiction of ASTM Committee D09 on Electrical and Electronic Insulating Materials and is the direct responsibility of Subcommittee D09.12 on Electrical Tests.

Current edition approved Jan. 1, 2012. Published February 2012. Originally approved in 1977. Last previous edition approved in 2007 as D3638 – 07. DOI: 10.1520/D3638-12.

<sup>2</sup> For referenced ASTM standards, visit the ASTM website, www.astm.org, or contact ASTM Customer Service at service@astm.org. For *Annual Book of ASTM Standards* volume information, refer to the standard's Document Summary page on the ASTM website.

<sup>3</sup> The last approved version of this historical standard is referenced on www.astm.org.

<sup>4</sup> Available from the International Electrotechnical Commission, Geneva, Switzerland.

\*A Summary of Changes section appears at the end of this standard

The numerical value of the voltage which causes failure with the application of 50 drops of the electrolyte is arbitrarily called the comparative tracking index. This index provides an indication of the relative track resistance of the material.

## 5. Significance and Use

5.1 Electrical equipment can fail as a result of electrical tracking of insulating material that is exposed to various contaminating environments and surface conditions. There are a number of ASTM and other tests designed to quantify behavior of materials, especially at relatively high voltages. This method is an accelerated test which at relatively low test voltages, provides a comparison of the performance of insulating materials under wet and contaminated conditions. The comparative tracking index is not related directly to the suitable operating voltage in service.

5.2 When organic electrical insulating materials are subjected to conduction currents between electrodes on their surfaces, many minute tree-like carbonaceous paths or tracks are developed near the electrodes. These tracks are oriented randomly, but generally propagate between the electrodes under the influence of the applied potential difference. Eventually a series of tracks spans the electrode gap, and failure occurs by shorting of the electrodes.

5.3 The conditions specified herein are intended, as in other tracking test methods, to produce a condition conducive to the formation of surface discharges and possible subsequent tracking. Test conditions are chosen to reproducibly and conveniently accelerate a process; for this reason, they rarely reproduce the varied conditions found in actual service. Therefore, while tracking tests serve to differentiate materials under given conditions, results of tracking tests cannot be used to infer either direct or comparative service behavior of an application design. Rather, tracking test results provide a tool for judging the suitability of materials for a given application. The suitability can only be verified through testing the design in actual end use or under conditions which simulate end use as closely as possible.

## 6. Apparatus

6.1 The simplified electrical circuitry used in this test is illustrated in Fig. 1. For necessary information on the cleanliness of apparatus, see Annex A1. The essential components are as follows:

6.1.1 *Variable Power Source*, consisting of a transformer type supply, such as the combination T1 and T2 in Fig. 1, with a variable output of 0 to 1000 V, 60 Hz capable of maintaining a current of 1 A (1 kVA).

6.1.2 *Voltmeter (V1)*, capable of measuring the varying a-c output of the power source. A0 to 600-V voltmeter with an accuracy of at least  $\pm 2.5\%$  of full scale.

6.1.3 *Ammeter (A1)*, with a range of 0 to 1 A a-c and an accuracy of at least  $\pm 10\%$  of full scale.

6.1.4 *Current Limiting Resistor (R1)*, continuously variable, wire wound, rated at greater than 1 A.

6.1.5 *Shorting Switch (S1)*, single-pole single-throw rated at 1000 V and greater than 1 A.

6.1.5.1 A shorting switch is optional. See Annex A2.

6.1.6 *Over-Current Relay (R0)*, which is inserted in the circuit shall not trip at currents up to 0.1 A. Use a relay having a tripping time on short circuit of at least 0.5 s and a current limited on short circuit to 1 A with a tolerance of  $\pm 10\%$  at a power factor of 0.9 to 1.0.

6.1.6.1 The tripping action can be accomplished with suitable electronic circuitry or with a commercial circuit breaker.<sup>5</sup>

6.1.7 *Testing Fixture*, adjustable platform which supports the specimen and electrode setup.

6.1.8 *Platinum Electrodes*, having a rectangular cross section measuring 5 by 2 mm (0.2 by 0.08 in.), extending 20 mm (0.8 in) minimum from suitable mounting shanks (Fig. 2). Machine the end of each electrode to form a 30° chisel-point edge, having a radius from 0.05 to 0.10 mm, extending along the 5-mm (0.2-in) side of the electrode. This is the radius that generally results from polishing a “0 mm” radius electrode. Since the direction of polish can influence the results, polish all electrodes in a direction perpendicular to the long dimension of the electrode face.

6.1.9 *Dropping Apparatus*, capable of dropping the electrolyte precisely as specified in Section 9. Include in the dropping apparatus device for electrically starting and stopping the dropping of the electrolyte as well as a counting device for monitoring the number of drops. The orifice diameter of the drop mechanism is approximately 1.5 mm. If necessary, adjust

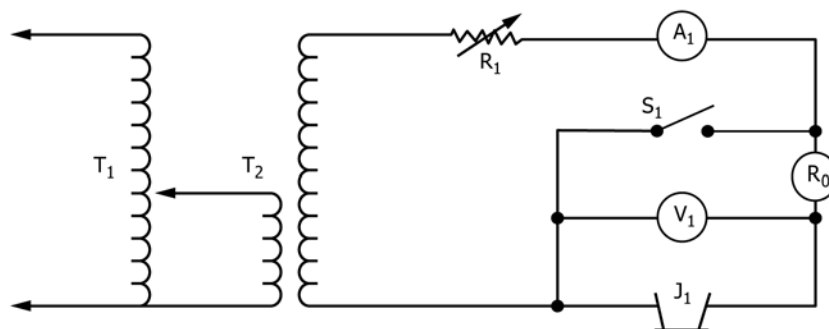

FIG. 1 Electrical Circuit Components

<sup>5</sup> The committee has been informed that the closest standard commercial breaker to that described in the IEC Method is Heinemann Model Series JA, Curve 2. The committee has not independently verified this information nor does it endorse that particular breaker.