



Standard Test Method for Traction Characteristics of the Athletic Shoe–Sports Surface Interface¹

This standard is issued under the fixed designation F2333; the number immediately following the designation indicates the year of original adoption or, in the case of revision, the year of last revision. A number in parentheses indicates the year of last reapproval. A superscript epsilon (ϵ) indicates an editorial change since the last revision or reapproval.

1. Scope

1.1 This test method covers specifications for the performance of sports shoe-surface traction measuring devices, but does not require a specific device or mechanism to be used. Figs. 1 and 2 show schematic diagrams of generic apparatus.

1.2 This test method is appropriate for measuring the effects of athletic shoe outsole design and materials on traction at the shoe-surface interface.

1.3 This test method is appropriate for measuring the effects of sport surface design and materials on traction at the shoe-surface interface.

1.4 This test method specifies test procedures that are appropriate for both field and laboratory testing.

1.5 Traction characteristics measured by this test method encompass friction forces developed between shoe outsoles and playing surfaces.

1.6 Traction characteristics measured by this test method encompass traction achieved by penetration of cleats or studs into playing surfaces.

1.7 This test method specifies test procedures for the measurement of traction during linear translational motion and rotational motion, but not simultaneous combinations of linear and translational motion.

1.8 The loads and load rates specified in this test method are specific to sports activities. The test method is not intended for measurement of slip resistance or traction of pedestrian footwear.

1.9 Test results obtained by this method shall be qualified by the characteristics of the specimen.

1.9.1 Comparative tests of surfaces shall be qualified by the characteristics of the shoes used to test the surfaces, including the cushioning, outsole material, and sole design.

1.9.2 Comparative tests of shoes shall be qualified by the pertinent characteristics of the surfaces on which shoes are tested, including the surface type, material, condition, and temperature.

1.10 This test method does not establish performance or safety criteria. The level of traction required between a sport shoe and surface varies with the level of performance and from individual to individual. The extent to which particular levels of traction contribute to individual athletic performance and risk of injury is not known.

1.11 The values stated in SI units are to be regarded as the standard.

1.12 *This standard may involve hazardous materials, operations and equipment. This standard does not purport to address all of the safety concerns, if any, associated with its use. It is the responsibility of the user of this standard to establish appropriate safety and health practices and determine the applicability of regulatory limitations prior to use.*

2. Referenced Documents

2.1 *SAE Standard:*

SAE J211 Recommended Practice for Instrumentation for Impact Tests²

3. Terminology

3.1 *Definitions:*

3.1.1 *footform*—a rigid form approximating the shape of a foot or shoe last to which the shoe under test may be tightly fitted and through which the loads required by this test method may be transmitted.

3.1.2 *traction*—resistance to relative motion between a shoe outsole and a sports surface that does not necessarily obey classical laws of friction.

3.1.2.1 *dynamic traction*—traction measured during relative sliding motion between the shoe and the surface.

3.1.2.2 *linear traction*—traction related to rectilinear motion parallel to the surface.

¹ This test method is under the jurisdiction of ASTM Committee F08 on Sports Equipment, Playing Surfaces, and Facilities and is the direct responsibility of Subcommittee F08.54 on Athletic Footwear.

Current edition approved Nov. 1, 2011. Published February 2012. Originally approved in 2004. Last previous edition approved in 2004 as F2333 – 04. DOI: 10.1520/F2333-04R11.

² Available from Society of Automotive Engineers (SAE), 400 Commonwealth Dr., Warrendale, PA 15096-0001.

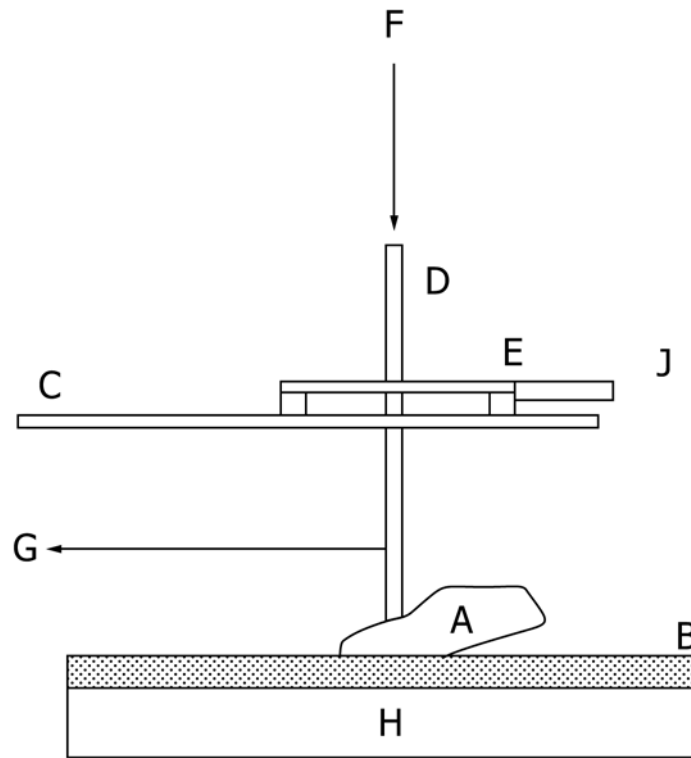

- A. Shoe under test, mounted on a footform.
- B. Surface under test.
- C. Guide rails with linear bearings or other means of maintaining rectilinear motion.
- D, E. Vertical shaft and bearing mounted carriage or other means of maintaining motion parallel to the plane of the shoe-surface interface.
- F. Weights, actuator or other means of applying a downward vertical force.
- G. Actuator or other means of applying a horizontal force.
- H. Force plate or other means of measuring vertical and horizontal forces.
- J. Velocity transducer.

FIG. 1 Schematic Diagram of a Generic Device for Measuring Linear Traction

3.1.2.3 *rotational traction*—traction related to rotational motion about an axis normal to the surface.

3.1.2.4 *static traction*—traction measured at the start of relative sliding motion between the shoe and the surface.

3.1.3 *traction ratio*—ratio of the traction force or torque and the normal force acting at the shoe-surface interface.

3.1.3.1 *dynamic traction ratio* (T_k , R_k)—linear or rotational traction ratio measured during constant velocity relative motion between the shoes and the surface.

3.1.3.2 *linear traction ratio* (T)—ratio of the force resisting relative rectilinear motion of the shoe parallel to the surface and the normal force at the shoe-surface interface.

3.1.3.3 *rotational traction ratio* (R)—ratio of the torque resisting relative rotational motion about an axis normal to the surface and the normal force acting at the shoe-surface interface.

3.1.3.4 *static traction ratio* (T_s , R_s)—linear or rotational traction ratio measured at the start of relative sliding motion between the shoe and the surface.

4. Summary of Test Method

4.1 A test shoe outsole or specimen is tested for traction characteristics on the type of playing surface for which the shoe is intended.

4.2 A shoe containing the outsole to be tested is pulled over a foot form, creating a tight fit capable of properly transmitting forces through the shoe material to the outsole-playing surface interface. Alternatively, an outsole material specimen can be fastened to a mounting plate and tested in the same manner as an outsole on an intact shoe.

4.3 The shoe on the footform is loaded against the test surface under a normal load specific to the sport category for which the shoe is intended. These normal loads, depending upon the sport, will typically be higher than an athlete's body weight. Normal loads, and the shoe axes along which traction needs are greatest, have been determined by research. Some of the loading conditions that have relevance for traction testing of outsoles designed for particular sports are itemized by sport category in Table 1. Tests should be conducted at these normal loads or at a normal load of 1000 ± 75 N unless otherwise specified. The normal loads can be applied by means of weights or hydraulic cylinders, springs in compression or other appropriate means and transmitted through a shaft to which the footform is securely attached.

4.4 The normal load is distributed entirely beneath the distal half or the forefoot region of the outsole unless otherwise specified. The proximal half or the rearfoot should not contact the playing surface except as noted in Table 1. Alternatively, if deemed appropriate for the sports movement for which the

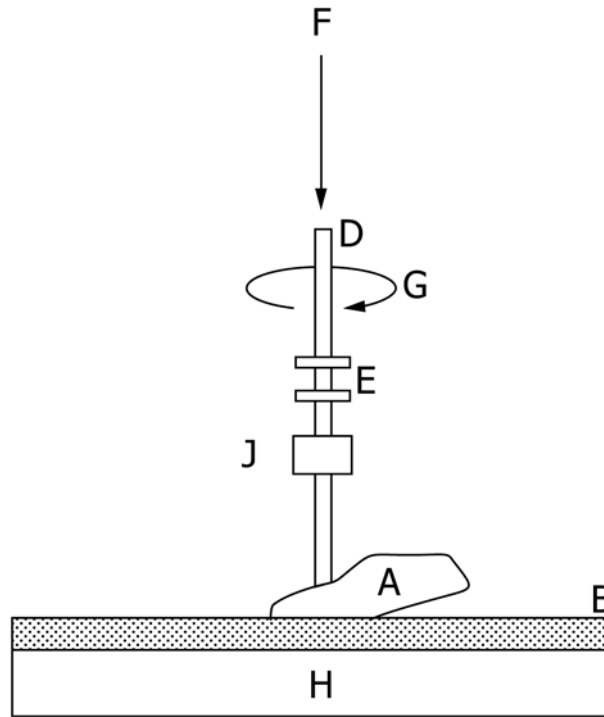

- A. Shoe under test, mounted on a footform.
- B. Surface under test.
- D, E. Vertical shaft and bearings or other means of constraining rotation about the vertical axis parallel to the plane of the shoe-surface interface.
- F. Weights, actuator or other means of applying a downward vertical force.
- G. Actuator or other means of applying a torque.
- H. Force plate or other means of measuring vertical force and torque about the vertical axis.
- J. Angular velocity transducer.

FIG. 2 Schematic Diagram of a Generic Device for Measuring Rotational Traction

TABLE 1 Distribution of Normal Loads and Application of Pulling Forces

Sport	Movement	Normal Load (N)	Load Distribution	Direction of Motion
Running ^A	Push-off	800	Forefoot	Distal-proximal
Sprinting	Push-off	1500	Forefoot	Distal-proximal
Tennis, basketball, ^B soccer, ^C football	Cutting	2200	Forefoot	Medial-lateral
	Stopping	3000	Forefoot	Proximal-distal
	Shuffling ^D	1300	Forefoot	Medial-lateral
	Starting	1500	Forefoot	Distal-proximal
Football	Pushing	900	Forefoot	Distal-proximal
Aerobic dance		500	Forefoot	Medial-lateral
Golf	Downswing	600	Lateral outsole	Medial-lateral

^A Valiant, G. A., "Friction-Slipping-Traction," *Sportverletzung Sportschaden*, 7, 1993, pp. 171-178.

^B Valiant, G. A. and Eden, K. B., "Evaluating Basketball Shoe Design with Ground Reaction Forces," *Proceedings of the Second North American Congress on Biomechanics*, Chicago, August 24-28, 1992, pp. 271-272.

^C Valiant, G. A., "Ground Reaction Forces Developed on Artificial Turf," *Science and Football*, T. Reilly, A. Lees, and W. J. Murphy, Eds., E. & F.N. Spon, London, 1988, pp. 406-415.

^D McClay, I. S., Robinson, J. R., et al., "A Profile of Ground Reaction Forces in Professional Basketball," *Journal of Applied Biomechanics*, 10(3), 1994, pp. 222-236.

shoe outsole design is intended, normal loads are distributed uniformly beneath the proximal half or the rearfoot portion of the outsole. If the shoe construction typically includes a midsole that provides cushioning, an appropriate midsole

should be included in the test shoe. If the test involves a specimen of outsole material fastened to a mounting plate, an equivalent midsole material of appropriate thickness is to be included between the mounting plate and the outsole material.

NOTE 1—The cushioning material helps to distribute normal loads more uniformly between the outsole and the playing surface. The cushion does not reproduce the distribution of loads transmitted through the shoe bottom to the outsole by the loaded human foot, but does increase test repeatability.

4.5 For linear traction measurements, a linear actuator is used to overcome the static traction and produce relative rectilinear motion of the shoe and surface, parallel to the shoe outsole-playing surface interface. The actuator may be pneumatically, hydraulically, or electrically driven. The distance of relative sliding motion between the shoe and the surface shall be a minimum of 20 cm, unless the interacting surfaces deform or fail at a smaller distance.

4.6 Sliding velocity shall be recorded and reported. The recommended minimum sliding velocity is 0.3 m s⁻¹.

NOTE 2—Under some conditions, for example, cleated shoes on artificial turf, spiked shoes on running tracks, it may not be possible to generate sliding at the recommended velocity. Under these circumstances, the force and velocity developed should be recorded and dynamic traction coefficients should not be reported.

4.7 For rotational traction measurements, the loaded shoe outsole is rotated about the vertical shaft transmitting the normal loads. The rotary motion may be applied manually, or by means of a rotary actuator. The minimum rotation applied

shall be 90° unless the interacting surfaces deform or fail at a lesser rotation. The minimum rate of rotation shall be 45°/s. Angular velocity shall be recorded and reported.

4.8 For linear traction tests, the measured variables are normal forces, horizontal or traction forces, and sliding velocity. For rotational traction tests, measured variables are normal forces, the moment (torque) resisting rotation about a vertical axis, and angular velocity during rotation. Traction ratios are calculated from these measurements.

4.9 All variables are recorded as functions of time, from before the application of horizontal or rotational motion until after the cessation of motion.

5. Significance and Use

5.1 This test method will be used by athletic footwear manufacturers to characterize the traction of the athletic shoe-sports surface interface, and as a tool for development of athletic shoe outsoles.

5.2 This test method will be used by researchers to determine the effect of sport surface conditions (for example, moisture, grass species, turf density, soil texture, soil composition, and so forth) on traction characteristics of the athletic shoe-sports surface interface.

5.3 This test method will be used by sports surface manufacturers to characterize the traction of the athletic shoe-sports surface interface, and as a tool for development of sports surfaces.

5.4 Careful adherence to the requirements and recommendations of this test method will provide results that compare with results from different laboratory sources.

5.5 The method will be used to research relationships between traction at athletic shoe-sports surface interfaces and athletic performance or injury. This research may lead to recommendations for appropriate levels of traction.

6. Apparatus

6.1 A footform.

6.2 A means of securely mounting surface samples to be tested and of controlling or constraining relative motion between the footform-mounted shoe and the surface.

6.3 A means of applying a minimum normal load of 1000 N through the footform is required. The normal load should be adjustable within ± 75 N. Typical means of load application include weights, hydraulic cylinders, and compressed air cylinders.

6.4 A means of producing relative sliding motion between the shoe and the surface. Typical methods of applying horizontal motion include linear actuators, hydraulic cylinders, compressed air cylinders, and variable speed motors. It is recommended that the velocity of the actuator be controllable. Since traction ratios at the shoe-surface interface may exceed 1.0, the motion generating device must be capable of applying horizontal forces that are even higher than the applied normal forces.

NOTE 3—Under some circumstances (for example, tests with portable equipment used in the field) it may be necessary to produce relative sliding

motion manually (for example, by means of manually drawn cables). Manual induction of motion is not recommended because it may be more variable than controlled mechanical actuators.

6.5 Guides, or a means of maintaining rectilinear motion parallel to the shoe-playing surface interface, such as low friction bearings, are required.

6.6 A means of maintaining the outsole or sample perpendicular to the playing surface during rotation (for example, low friction rotary bearings) is required for measurement of rotational traction ratios.

6.7 Transducers, signal conditioners and other instrumentation are required to measure normal force, horizontal force, torque, velocity, and angular velocity. The performance of the measurement systems shall, as a minimum, conform to the requirements of a CFC Class 100 Data Channel, as defined by SAE J211. Anti-aliasing filters shall be used to filter data channels at a -3dB cutoff frequency of 250 ± 20 Hz before they are digitized.

NOTE 4—For laboratory-based measurements, an appropriate means of measuring forces and torques is a multi-axis force plate to which the surface being tested is securely attached (Figs. 1 and 2).

6.8 The apparatus should have the capability of differentiating static traction forces from dynamic traction forces. Typically, the velocity or angular velocity measuring transducer will be used for this purpose.

6.9 The data acquisition system should sample and store force, torque, velocity, and angular velocity signals at a minimum sampling rate of 500 samples/s.

6.10 The complete apparatus used to make the traction measurements shall be anchored or have a large enough inertia to prevent it from being moved by the application of linear or rotary motion to the shoe-surface system under test.

7. Procedure

7.1 Select a sample of the playing surface appropriate for the outsole to be tested and prepare it in accordance with the required conditions of the traction test.

7.2 If the test is conducted in the field, locate the traction testing device on an area of the playing surface that has the required conditions.

7.3 Adjust the normal force to a magnitude appropriate to the sport for which the outsole is intended. The normal force shall be either the appropriate value selected from Table 1 (± 75 N) or 1000 ± 75 N.

7.4 Clean all debris and foreign material, mould release compounds, and so forth from the shoe outsole, unless the test method is being used to determine the effects of a specific contaminant on traction.

7.5 Attach a shoe with the outsole to be tested or a test sample to the device component that transmits the high normal force. Orient the outsole along a desired axis of translation (see Table 1).

7.6 Lower the sample onto the playing surface.

7.7 For measurements of linear traction, immediately induce a horizontal motion to the outsole, parallel to the playing