



Designation: D86 – 11b

Standard Test Method for Distillation of Petroleum Products at Atmospheric Pressure¹

This standard is issued under the fixed designation D86; the number immediately following the designation indicates the year of original adoption or, in the case of revision, the year of last revision. A number in parentheses indicates the year of last reapproval. A superscript epsilon (ϵ) indicates an editorial change since the last revision or reapproval.

This standard has been approved for use by agencies of the Department of Defense.

1. Scope*

1.1 This test method covers the atmospheric distillation of petroleum products using a laboratory batch distillation unit to determine quantitatively the boiling range characteristics of such products as light and middle distillates, automotive spark-ignition engine fuels with or without oxygenates (see [Note 1](#)), aviation gasolines, aviation turbine fuels, diesel fuels, biodiesel blends up to 20 %, marine fuels, special petroleum spirits, naphthas, white spirits, kerosines, and Grades 1 and 2 burner fuels.

NOTE 1—An interlaboratory study was conducted in 2008 involving 11 different laboratories submitting 15 data sets and 15 different samples of ethanol-fuel blends containing 25 v%, 50 v%, and 75 v% ethanol. The results indicate that the repeatability limits of these samples are comparable or within the published repeatability of the method (with the exception of FBP of 75% ethanol-fuel blends). On this basis, it can be concluded that Test Method D86 is applicable to ethanol-fuel blends such as Ed75 and Ed85 (Specification [D5798](#)) or other ethanol-fuel blends with greater than 10 v% ethanol. See ASTM [RR:D02-1694](#) for supporting data.²

1.2 The test method is designed for the analysis of distillate fuels; it is not applicable to products containing appreciable quantities of residual material.

1.3 This test method covers both manual and automated instruments.

1.4 Unless otherwise noted, the values stated in SI units are to be regarded as the standard. The values given in parentheses are provided for information only.

1.5 **WARNING**—Mercury has been designated by many regulatory agencies as a hazardous material that can cause central nervous system, kidney and liver damage. Mercury, or its vapor, may be hazardous to health and corrosive to materials. Caution should be taken when handling mercury and

mercury containing products. See the applicable product Material Safety Data Sheet (MSDS) for details and EPA's website—<http://www.epa.gov/mercury/faq.htm>—for additional information. Users should be aware that selling mercury and/or mercury containing products into your state or country may be prohibited by law.

1.6 *This standard does not purport to address all of the safety concerns, if any, associated with its use. It is the responsibility of the user of this standard to establish appropriate safety and health practices and determine the applicability of regulatory limitations prior to use.*

2. Referenced Documents

2.1 All standards are subject to revision, and parties to agreement on this test method are to apply the most recent edition of the standards indicated below, unless otherwise specified, such as in contractual agreements or regulatory rules where earlier versions of the method(s) identified may be required.

2.2 ASTM Standards:³

- [D97 Test Method for Pour Point of Petroleum Products](#)
- [D323 Test Method for Vapor Pressure of Petroleum Products \(Reid Method\)](#)
- [D4057 Practice for Manual Sampling of Petroleum and Petroleum Products](#)
- [D4175 Terminology Relating to Petroleum, Petroleum Products, and Lubricants](#)
- [D4177 Practice for Automatic Sampling of Petroleum and Petroleum Products](#)
- [D4953 Test Method for Vapor Pressure of Gasoline and Gasoline-Oxygenate Blends \(Dry Method\)](#)
- [D5190 Test Method for Vapor Pressure of Petroleum Products \(Automatic Method\)](#)
- [D5191 Test Method for Vapor Pressure of Petroleum Products \(Mini Method\)](#)
- [D5798 Specification for Ethanol Fuel Blends for Flexible-Fuel Automotive Spark-Ignition Engines](#)

¹ This test method is under the jurisdiction of ASTM Committee [D02](#) on Petroleum Products and Lubricants and is the direct responsibility of Subcommittee [D02.08](#) on Volatility.

In the IP, the equivalent test method is published under the designation IP 123. It is under the jurisdiction of the Standardization Committee.

Current edition approved Dec. 1, 2011. Published February 2012. Originally approved in 1921. Last previous edition approved in 2011 as D86–11a. DOI: 10.1520/D0086-11B.

² Supporting data have been filed at ASTM International Headquarters and may be obtained by requesting Research Report [RR:D02-1694](#).

³ For referenced ASTM standards, visit the ASTM website, www.astm.org, or contact ASTM Customer Service at service@astm.org. For *Annual Book of ASTM Standards* volume information, refer to the standard's Document Summary page on the ASTM website.

*A Summary of Changes section appears at the end of this standard

- D5842** Practice for Sampling and Handling of Fuels for Volatility Measurement
- D5949** Test Method for Pour Point of Petroleum Products (Automatic Pressure Pulsing Method)
- D5950** Test Method for Pour Point of Petroleum Products (Automatic Tilt Method)
- D5985** Test Method for Pour Point of Petroleum Products (Rotational Method)
- D6300** Practice for Determination of Precision and Bias Data for Use in Test Methods for Petroleum Products and Lubricants
- E1** Specification for ASTM Liquid-in-Glass Thermometers
- E77** Test Method for Inspection and Verification of Thermometers
- E1272** Specification for Laboratory Glass Graduated Cylinders
- E1405** Specification for Laboratory Glass Distillation Flasks
- 2.3 *Energy Institute Standards*.⁴
- IP 69** Determination of Vapour Pressure—Reid Method
- IP 123** Petroleum Products—Determination of Distillation Characteristics
- IP 394** Determination of Air Saturated Vapour Pressure
- IP Standard Methods for Analysis and Testing of Petroleum and Related Products 1996—Appendix A**

3. Terminology

3.1 Definitions:

3.1.1 *decomposition*, *n*—of a hydrocarbon, the pyrolysis or cracking of a molecule yielding smaller molecules with lower boiling points than the original molecule.

3.1.2 *decomposition point*, *n*—in distillation, the corrected temperature reading that coincides with the first indications of thermal decomposition of the specimen.

3.1.3 *dry point*, *n*—in distillation, the corrected temperature reading at the instant the last drop of liquid evaporates from the lowest point in the flask.

3.1.4 *dynamic holdup*, *n*—in D86 distillation, the amount of material present in the neck of the flask, in the sidearm of the flask, and in the condenser tube during the distillation.

3.1.5 *emergent stem effect*, *n*—the offset in temperature reading caused by the use of total immersion mercury-in-glass thermometers in the partial immersion mode.

3.1.5.1 *Discussion*—In the partial immersion mode, a portion of the mercury thread, that is, the emergent portion, is at a lower temperature than the immersed portion, resulting in a shrinkage of the mercury thread and a lower temperature reading.

3.1.6 *end point (EP) or final boiling point (FBP)*, *n*—the maximum corrected thermometer reading obtained during the test.

3.1.6.1 *Discussion*—This usually occurs after the evaporation of all liquid from the bottom of the flask. The term maximum temperature is a frequently used synonym.

3.1.7 *front end loss*, *n*—loss due to evaporation during transfer from receiving cylinder to distillation flask, vapor loss during the distillation, and uncondensed vapor in the flask at the end of the distillation.

3.1.8 *fuel ethanol (Ed75-Ed85)*, *n*—blend of ethanol and hydrocarbon of which the ethanol portion is nominally 75 to 85 volume % denatured fuel ethanol. **D4175**

3.1.9 *initial boiling point (IBP)*, *n*—in D86 distillation, the corrected temperature reading at the instant the first drop of condensate falls from the lower end of the condenser tube.

3.1.10 *percent evaporated*, *n*—in distillation, the sum of the percent recovered and the percent loss.

3.1.10.1 *percent loss*, *n*—in distillation, one hundred minus the percent total recovery.

3.1.10.2 *corrected loss*, *n*—percent loss corrected for barometric pressure.

3.1.11 *percent recovered*, *n*—in distillation, the volume of condensate collected relative to the sample charge.

3.1.11.1 *percent recovery*, *n*—in distillation, maximum percent recovered relative to the sample charge.

3.1.11.2 *corrected percent recovery*, *n*—in distillation, the percent recovery, adjusted for the corrected percent loss.

3.1.11.3 *percent total recovery*, *n*—in distillation, the combined percent recovery and percent residue.

3.1.12 *percent residue*, *n*—in distillation, the volume of residue relative to the sample charge.

3.1.13 *rate of change (or slope)*, *n*—the change in temperature reading per percent evaporated or recovered, as described in 13.2.

3.1.14 *sample charge*, *n*—the amount of sample used in a test.

3.1.15 *temperature lag*, *n*—the offset between the temperature reading obtained by a temperature sensing device and the true temperature at that time.

3.1.16 *temperature measurement device*, *n*—a thermometer, as described in 6.3.1, or a temperature sensor, as described in 6.3.2.

3.1.16.1 *temperature reading*, *n*—the temperature obtained by a temperature measuring device or system that is equal to the thermometer reading described in 3.1.16.3.

3.1.16.2 *corrected temperature reading*, *n*—the temperature reading, as described in 3.1.16.1, corrected for barometric pressure.

3.1.16.3 *thermometer reading (or thermometer result)*, *n*—the temperature of the saturated vapor measured in the neck of the flask below the vapor tube, as determined by the prescribed thermometer under the conditions of the test.

3.1.16.4 *corrected thermometer reading*, *n*—the thermometer reading, as described in 3.1.16.3, corrected for barometric pressure.

4. Summary of Test Method

4.1 Based on its composition, vapor pressure, expected IBP or expected EP, or combination thereof, the sample is placed in

⁴ Available from Energy Institute, 61 New Cavendish St., London, WIG 7AR, U.K., <http://www.energyinst.org.uk>.

one of four groups. Apparatus arrangement, condenser temperature, and other operational variables are defined by the group in which the sample falls.

4.2 A 100-mL specimen of the sample is distilled under prescribed conditions for the group in which the sample falls. The distillation is performed in a laboratory batch distillation unit at ambient pressure under conditions that are designed to provide approximately one theoretical plate fractionation. Systematic observations of temperature readings and volumes of condensate are made, depending on the needs of the user of the data. The volume of the residue and the losses are also recorded.

4.3 At the conclusion of the distillation, the observed vapor temperatures can be corrected for barometric pressure and the data are examined for conformance to procedural requirements, such as distillation rates. The test is repeated if any specified condition has not been met.

4.4 Test results are commonly expressed as percent evaporated or percent recovered versus corresponding temperature, either in a table or graphically, as a plot of the distillation curve.

5. Significance and Use

5.1 The basic test method of determining the boiling range of a petroleum product by performing a simple batch distillation has been in use as long as the petroleum industry has existed. It is one of the oldest test methods under the jurisdiction of ASTM Committee D02, dating from the time when it was still referred to as the Engler distillation. Since the test method has been in use for such an extended period, a tremendous number of historical data bases exist for estimating end-use sensitivity on products and processes.

5.2 The distillation (volatility) characteristics of hydrocarbons have an important effect on their safety and performance, especially in the case of fuels and solvents. The boiling range gives information on the composition, the properties, and the behavior of the fuel during storage and use. Volatility is the major determinant of the tendency of a hydrocarbon mixture to produce potentially explosive vapors.

5.3 The distillation characteristics are critically important for both automotive and aviation gasolines, affecting starting, warm-up, and tendency to vapor lock at high operating temperature or at high altitude, or both. The presence of high boiling point components in these and other fuels can significantly affect the degree of formation of solid combustion deposits.

5.4 Volatility, as it affects rate of evaporation, is an important factor in the application of many solvents, particularly those used in paints.

5.5 Distillation limits are often included in petroleum product specifications, in commercial contract agreements, process refinery/control applications, and for compliance to regulatory rules.

6. Apparatus

6.1 Basic Components of the Apparatus:

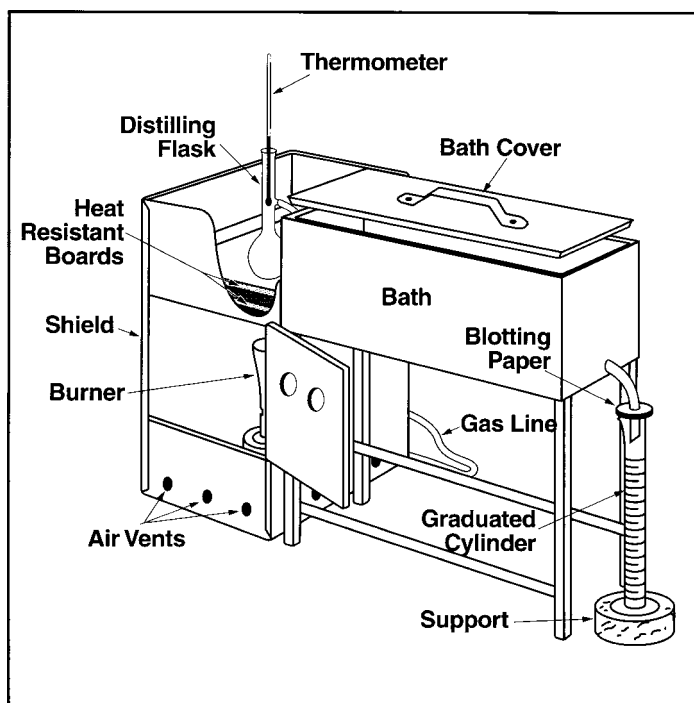

FIG. 1 Apparatus Assembly Using Gas Burner

6.1.1 The basic components of the distillation unit are the distillation flask, the condenser and associated cooling bath, a metal shield or enclosure for the distillation flask, the heat source, the flask support, the temperature measuring device, and the receiving cylinder to collect the distillate.

6.1.2 Figs. 1 and 2 are examples of manual distillation units.

6.1.3 In addition to the basic components described in 6.1.1, automated units also are equipped with a system to measure and automatically record the temperature and the associated recovered volume in the receiving cylinder.

6.2 A detailed description of the apparatus is given in Annex A2.

6.3 Temperature Measuring Device:

6.3.1 Mercury-in-glass thermometers, if used, shall be filled with an inert gas, graduated on the stem and enamel backed. They shall conform to Specification E1 or IP Standard Methods for Analysis and Testing of Petroleum and Related Products 1996—Appendix A, or both, for thermometers ASTM 7C/IP 5C and ASTM 7F for the low range thermometers, and ASTM 8C/IP 6C and ASTM 8F for the high range thermometers.

6.3.1.1 Thermometers that have been exposed for an extended period above an observed temperature of 370°C shall not be reused without a verification of the ice point or checked as prescribed in Specification E1 and Test Method E77.

NOTE 2—At an observed thermometer reading of 370°C, the temperature of the bulb is approaching a critical range in the glass and the thermometer may lose its calibration.

6.3.2 Temperature measurement systems other than those described in 6.3.1 are satisfactory for this test method, provided that they exhibit the same temperature lag, emergent stem effect, and accuracy as the equivalent mercury-in-glass thermometer.

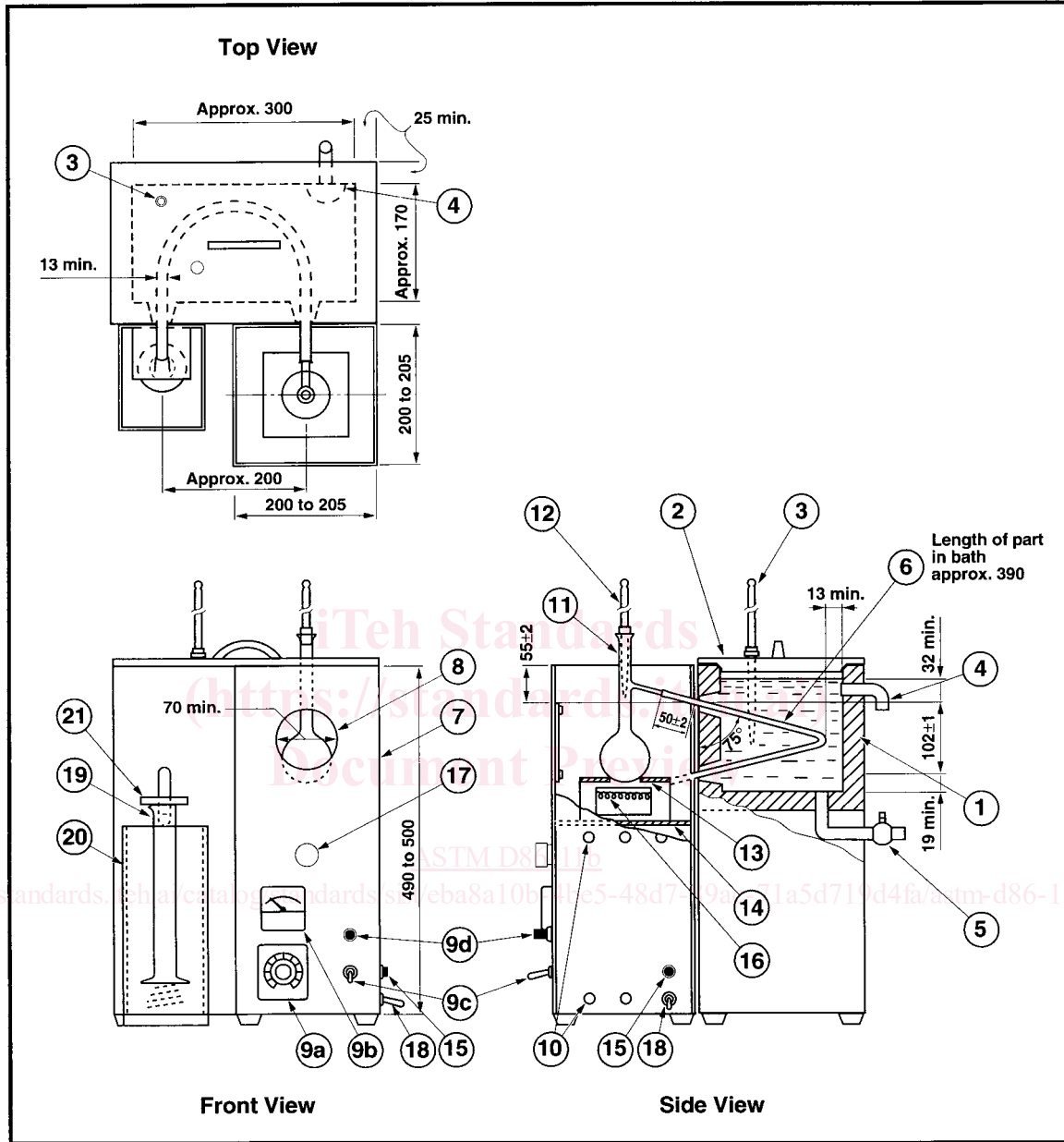

- | | |
|---------------------------|---|
| 1-Condenser bath | 11-Distillation flask |
| 2-Bath cover | 12-Temperature sensor |
| 3-Bath temperature sensor | 13-Flask support board |
| 4-Bath overflow | 14-Flask support platform |
| 5-Bath drain | 15-Ground connection |
| 6-Condenser tube | 16-Electric heater |
| 7-Shield | 17-Knob for adjusting level of support platform |
| 8-Viewing window | 18-Power source cord |
| 9a-Voltage regulator | 19-Receiver cylinder |
| 9b-Voltmeter or ammeter | 20-Receiver cooling bath |
| 9c-Power switch | 21-Receiver cover |
| 9d-Power light indicator | |
| 10-Vent | |

FIG. 2 Apparatus Assembly Using Electric Heater

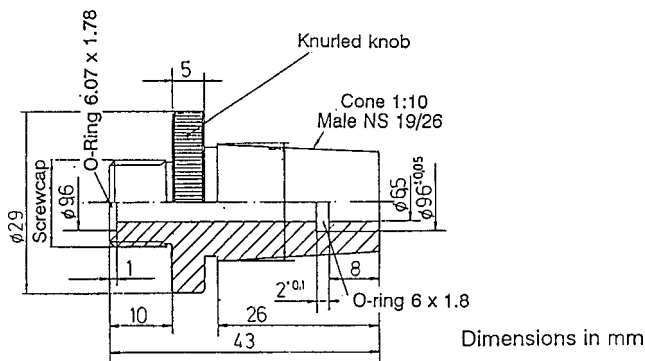

FIG. 3 PTFE Centering Device for Ground Glass Joint

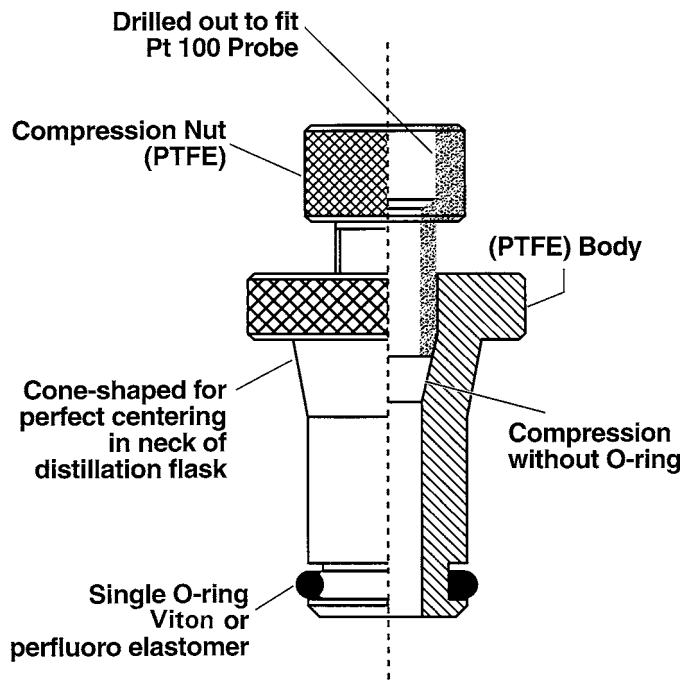

FIG. 4 Example of Centering Device Designs for Straight-Bore Neck Flasks

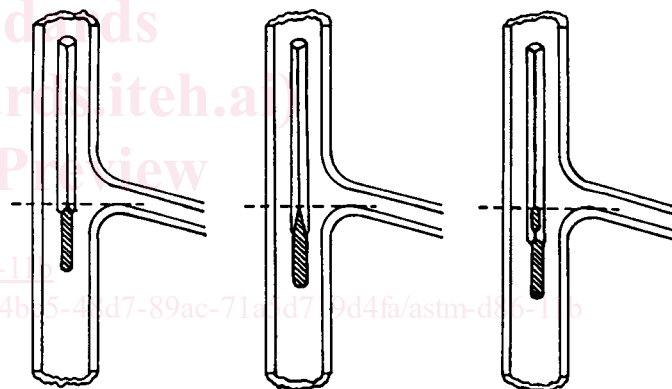

FIG. 5 Position of Thermometer in Distillation Flask

6.3.2.1 The electronic circuitry or the algorithms, or both, used shall include the capability to simulate the temperature lag of a mercury-in-glass thermometer.

6.3.2.2 Alternatively, the sensor can also be placed in a casing with the tip of the sensor covered so that the assembly, because of its adjusted thermal mass and conductivity, has a temperature lag time similar to that of a mercury-in-glass thermometer.

NOTE 3—In a region where the temperature is changing rapidly during the distillation, the temperature lag of a thermometer can be as much as 3 seconds.

6.3.3 In case of dispute, the referee test method shall be carried out with the specified mercury-in-glass thermometer.

6.4 Temperature Sensor Centering Device:

6.4.1 The temperature sensor shall be mounted through a snug-fitting device designed for mechanically centering the sensor in the neck of the flask without vapor leakage. Examples of acceptable centering devices are shown in Figs. 3 and 4. (Warning—The use of a plain stopper with a hole drilled through the center is not acceptable for the purpose described in 6.4.1.)

NOTE 4—Other centering devices are also acceptable, as long as they position and hold the temperature sensing device in the proper position in the neck of the distillation column, as shown in Fig. 5 and described in 10.5.

NOTE 5—When running the test by the manual method, products with a low IBP may have one or more readings obscured by the centering device. See also 10.14.3.1.

6.5 Automated equipment manufactured in 1999 and later shall be equipped with a device to automatically shut down power to the unit and to spray an inert gas or vapor in the chamber where the distillation flask is mounted in the event of fire.

NOTE 6—Some causes of fires are breakage of the distillation flask, electrical shorts, and foaming and spilling of liquid sample through the top opening of the flask.

6.6 **Barometer**—A pressure measuring device capable of measuring local station pressure with an accuracy of 0.1 kPa (1 mm Hg) or better, at the same elevation relative to sea level as the apparatus in the laboratory. (Warning —Do not take readings from ordinary aneroid barometers, such as those used at weather stations and airports, since these are precorrected to give sea level readings.)

7. Sampling, Storage, and Sample Conditioning

7.1 Determine the Group characteristics that correspond to the sample to be tested (see Table 1). Where the procedure is dependent upon the group, the section headings will be so marked.

7.2 Sampling:

7.2.1 Sampling shall be done in accordance with Practice D4057 or D4177 and as described in Table 2.

7.2.1.1 **Group 1**—Condition the sample container to below 10°C, preferably by filling the bottle with the cold liquid sample and discarding the first sample. If this is not possible because, for instance, the product to be sampled is at ambient temperature, the sample shall be drawn into a bottle prechilled to below 10°C, in such a manner that agitation is kept at a minimum. Close the bottle immediately with a tight-fitting closure. (Warning—Do not completely fill and tightly seal a cold bottle of sample because of the likelihood of breakage on warming.)

TABLE 1 Group Characteristics

	Group 1	Group 2	Group 3	Group 4
Sample characteristics				
Distillate type				
Vapor pressure at				
37.8°C, kPa	≥65.5	<65.5	<65.5	<65.5
100°F, psi	≥9.5	<9.5	<9.5	<9.5
(Test Methods D323 , D4953 , D5190 , D5191 , D5842 , IP 69 or IP 394)				
Distillation, IBP °C			≤100	>100
°F			≤212	>212
EP °C	≤250	≤250	>250	>250
°F	≤482	≤482	>482	>482

7.2.1.2 *Groups 2, 3, and 4*—Collect the sample at ambient temperature. After sampling, close the sample bottle immediately with a tight-fitting closure.

7.2.1.3 If the sample received by the testing laboratory has been sampled by others and it is not known whether sampling has been performed as described in 7.2, the sample shall be assumed to have been so sampled.

7.3 Sample Storage:

7.3.1 If testing is not to start immediately after collection, store the samples as indicated in 7.3.2, 7.3.3, and Table 2. All samples shall be stored away from direct sunlight or sources of direct heat.

7.3.2 *Group 1*—Store the sample at a temperature below 10°C.

NOTE 7—If there are no, or inadequate, facilities for storage below 10°C, the sample may also be stored at a temperature below 20°C, provided the operator ensures that the sample container is tightly closed and leak-free.

7.3.3 *Group 2*—Store the sample at a temperature below 10°C.

NOTE 8—If there are no, or inadequate, facilities for storage below 10°C, the sample may also be stored at a temperature below 20°C, provided the operator ensures that the sample container is tightly closed and leak-free.

7.3.4 *Groups 3 and 4*—Store the sample at ambient or lower temperature.

7.4 Sample Conditioning Prior to Analysis:

7.4.1 Samples shall be conditioned to the temperature shown in Table 2 before opening the sample container.

7.4.1.1 *Groups 1 and 2*—Samples shall be conditioned to a temperature of less than 10°C (50°F) before opening the sample container, except when the sample is to be immediately tested and is already at the prescribed sample temperature in Table 3.

7.4.1.2 *Groups 3 and 4*—If the sample is not fluid at ambient temperature, it is to be heated to a temperature of 9 to 21°C above its pour point (Test Method **D97**, **D5949**, or **D5985**) prior to analysis. If the sample has partially or completely solidified during storage, it shall be vigorously shaken after melting prior to opening the sample container to ensure homogeneity.

7.4.1.3 If the sample is not fluid at room temperature, the temperature ranges shown in Table 2 for the flask and for the sample do not apply.

7.5 Wet Samples:

7.5.1 Samples of materials that visibly contain water are not suitable for testing. If the sample is not dry, obtain another sample that is free from suspended water.

7.5.2 *Groups 1 and 2*—If such a sample cannot be obtained, the suspended water can be removed by maintaining the sample at 0 to 10°C, adding approximately 10 g of anhydrous sodium sulfate per 100 mL of sample, shaking the mixture for approximately 2 min, and then allowing the mixture to settle for approximately 15 min. Once the sample shows no visible signs of water, use a decanted portion of the sample, maintained between 1 and 10°C, for the analysis. Note in the report that the sample has been dried by the addition of a desiccant.

NOTE 9—Suspended water in hazy samples in Groups 1 and 2 can be removed by the addition of anhydrous sodium sulfate and separating the liquid sample from the drying agent by decanting without statistically affecting the results of the test.⁵

7.5.3 *Groups 3 and 4*—In cases in which a water-free sample is not practical, the suspended water can be removed by shaking the sample with anhydrous sodium sulfate or other suitable drying agent and separating it from the drying agent by decanting. Note in the report that the sample has been dried by the addition of a desiccant.

8. Preparation of Apparatus

8.1 Refer to Table 3 and prepare the apparatus by choosing the appropriate distillation flask, temperature measuring device, and flask support board, as directed for the indicated group. Bring the temperature of the receiving cylinder, the flask, and the condenser bath to the indicated temperature.

8.2 Make any necessary provisions so that the temperature of the condenser bath and the receiving cylinder will be maintained at the required temperatures. The receiving cylinder shall be in a bath such that either the liquid level is at least as high as the 100-mL mark or the entire receiving cylinder is surrounded by an air circulation chamber.

8.2.1 *Groups 1, 2, and 3*—Suitable media for low temperature baths include, but are not limited to, chopped ice and water, refrigerated brine, and refrigerated ethylene glycol.

8.2.2 *Group 4*—Suitable media for ambient and higher bath temperatures include, but are not limited to, cold water, hot water, and heated ethylene glycol.

8.3 Remove any residual liquid in the condenser tube by swabbing with a piece of soft, lint-free cloth attached to a cord or wire.

9. Calibration and Standardization

9.1 *Temperature Measurement System*—Temperature measurement systems using other than the specified mercury-in-glass thermometers shall exhibit the same temperature lag, emergent stem effect, and accuracy as the equivalent mercury-in-glass thermometer. Confirmation of the calibration of these temperature measuring systems shall be made at intervals of not more than six months, and after the system has been replaced or repaired.

⁵ Supporting data have been filed at ASTM International Headquarters and may be obtained by requesting Research Report RR:D02-1455.

TABLE 2 Sampling, Storage, and Sample Conditioning

		Group 1	Group 2	Group 3	Group 4
Temperature of sample bottle	°C	<10			
	°F	<50			
Temperature of stored sample	°C	<10 ^A	<10	ambient	ambient
	°F	<50 ^A	<50	ambient	ambient
Temperature of sample after conditioning prior to analysis	°C	<10 ^B	<10 ^B	Ambient or 9 to 21°C above pour point ^C	Ambient or Ambient or 9 to 21°C above pour point ^C
	°F	<50	<50	Ambient or 48 to 70°F above pour point ^C	Ambient or Ambient or 48 to 70°F above pour point ^C
If sample is wet		resample	resample		
If resample is still wet ^D		dry in accordance with 7.5.2		dry in accordance with 7.5.3	

^A Under certain circumstances, samples can also be stored at temperatures below 20°C (68°F). See also 7.3.2 and 7.3.3.

^B If sample is to be immediately tested and is already at the temperature prescribed in Table 3, see 7.4.1.1.

^C If sample is (semi)-solid at ambient temperature, see also 10.3.1.1.

^D If sample is known to be wet, resampling may be omitted. Dry sample in accordance with 7.5.2 and 7.5.3.

TABLE 3 Preparation of Apparatus and Specimen

		Group 1	Group 2	Group 3	Group 4
Flask, mL		125	125	125	125
ASTM distillation thermometer		7C (7F)	7C (7F)	7C (7F)	8C (8F)
IP distillation thermometer range		low	low	low	high
Flask support board		B	B	C	C
diameter of hole, mm		38	38	50	50
Temperature at start of test					
Flask	°C	13–18	13–18	13–18	not above
	°F	55–65	55–65	55–65	ambient
Flask support and shield		not above	not above	not above	ambient
		ambient	ambient	ambient	
Receiving cylinder and sample					
	°C	13–18	13–18	13–18 ^A	13–ambient ^A
	°F	55–65	55–65	55–65 ^A	55–ambient ^A

^A See 10.3.1.1 for exceptions.

9.1.1 The accuracy and the calibration of the electronic circuitry or computer algorithms, or both, shall be verified by the use of a standard precision resistance bench. When performing this verification, no algorithms shall be used to correct the temperature for lag and the emergent stem effect (see manufacturer's instructions).

9.1.2 Verification of the calibration of temperature measuring devices shall be conducted by distilling toluene in accordance with Group 1 of this test method and comparing the 50 % recovered temperature with that shown in Table 4.⁶

9.1.2.1 If the temperature reading is not within the values shown in Table 4 for the respective apparatus being used (see Note 11 and Table 4), the temperature measurement system shall be considered defective and shall not be used for the test.

NOTE 10—Toluene is used as a verification fluid for calibration; it will yield almost no information on how well an electronic measurement system simulates the temperature lag of a liquid-in-glass thermometer.

9.1.2.2 Reagent grade toluene and hexadecane (cetane), conforming to the specifications of the Committee on Analytical Reagents of the American Chemical Society,⁷ shall be used.

⁶ Supporting data have been filed at ASTM International Headquarters and may be obtained by requesting Research Report RR:D02-1580.

⁷ *Reagent Chemicals, American Chemical Society Specifications*, American Chemical Society, Washington, DC. For Suggestions on the testing of reagents not listed by the American Chemical Society, see *Annual Standards for Laboratory Chemicals*, BDH Ltd., Poole, Dorset, U.K., and the *United States Pharmacopeia and National Formulary*, U.S. Pharmacopeial Convention, Inc. (USPC), Rockville, MD.

However, other grades may also be used, provided it is first ascertained that the reagent is of sufficient purity to permit its use without lessening the accuracy of the determination.

NOTE 11—At 101.3 kPa, toluene is shown in reference manuals as boiling at 110.6°C when measured using a partial immersion thermometer. Because this test method uses thermometers calibrated for total immersion, the results typically will be lower and, depending on the thermometer and the situation, may be different for each thermometer. At 101.3 kPa, hexadecane is shown in reference manuals as boiling at 287.0°C when measured using a partial immersion thermometer. Because this test method uses thermometers calibrated for total immersion, the results typically will be lower, and, depending on the thermometer and the situation, may be different for each thermometer.

9.1.3 A procedure to determine the magnitude of the temperature lag is described in Annex A3.

9.1.4 A procedure to emulate the emergent stem effect is described in Appendix X4.

9.1.5 To verify the calibration of the temperature measurement system at elevated temperatures, use hexadecane. The temperature measurement system shall indicate, at 50% recovered, a temperature comparable to that shown in Table 4 for the respective apparatus under Group 4 distillation conditions.

NOTE 12—Because of the high melting point of hexadecane, Group 4 verification distillations will have to be carried out with condenser temperatures >20°C.

9.2 Automated Method:

9.2.1 *Level Follower*—For an automated distillation apparatus, the level follower/recording mechanism of the apparatus

TABLE 4 True and Min and Max D86 50 % Recovered Boiling Points (°C)^A

		Manual		Automated	
		Distillation conditions min D86 50 % boiling point	Distillation conditions max D86 50 % boiling point	Distillation conditions min D86 50 % boiling point	Distillation conditions max D86 50 % boiling point
Toluene	ASTM/IP true boiling point	Group 1, 2, and 3	Group 1, 2, and 3	Group 1, 2, and 3	Group 1, 2, and 3
	110.6	105.9	111.8	108.5	109.7
Hexadecane	ASTM/IP true boiling point	Group 4	Group 4	Group 4	Group 4
	287.0	272.2	283.1	277.0	280.0

^A The manual and automated temperatures show in this table are the values for the 95 % tolerance interval for the 99 % population coverage. The proposed tolerance is approximately 3 × sigma. Information on the values in this table can be found in RR:D02-1580.

shall have a resolution of 0.1 volume % or better with a maximum error of 0.3 volume % between the 5 and 100 volume % points. The calibration of the assembly shall be verified in accordance with manufacturer's instructions at intervals of not more than three months and after the system has been replaced or repaired.

NOTE 13—The typical calibration procedure involves verifying the output with the receiver containing 5 and 100 volume % of material respectively.

9.2.2 *Barometric Pressure*—At intervals of not more than six months, and after the system has been replaced or repaired, the barometric reading of the instrument shall be verified against a barometer, as described in 6.6.

10. Procedure

10.1 Record the prevailing barometric pressure.

10.2 *Groups 1 and 2*—Ensure that the sample is conditioned in accordance with Table 2. Fit a low range thermometer provided with a snug-fitting cork or stopper of silicone rubber, or equivalent polymeric material, tightly into the neck of the sample container and bring the temperature of the sample to the temperature indicated in Table 3.

10.3 *Groups 1, 2, 3, and 4*—Check that the temperature of the sample is as shown in Table 3. Pour the specimen precisely to the 100-mL mark of the receiving cylinder, and transfer the contents of the receiving cylinder as completely as practical into the distillation flask, ensuring that none of the liquid flows into the vapor tube.

NOTE 14—It is important that the difference between the temperature of the specimen and the temperature of the bath around the receiving cylinder is as small as practically possible. A difference of 5°C can make a difference of 0.7 mL.

10.3.1 *Groups 3 and 4*—If the sample is not fluid at ambient temperature, it is to be heated to a temperature between 9 and 21°C above its pour point (Test Methods D97, D5949, D5950, or D5985) prior to analysis. If the sample has partially or completely solidified in the intervening period, it shall be vigorously shaken after melting, and prior to sampling, to ensure homogeneity.

10.3.1.1 If the sample is not fluid at ambient temperatures, disregard the temperature range shown in Table 3 for the receiving cylinder and sample. Prior to analysis, heat the receiving cylinder to approximately the same temperature as

the sample. Pour the heated specimen precisely to the 100-mL mark of the receiving cylinder, and transfer the contents of the receiving cylinder as completely as practical into the distillation flask, ensuring that none of the liquid flows into the vapor tube.

NOTE 15—Any material that evaporates during the transfer will contribute to the loss; any material that remains in the receiving cylinder will contribute to the observed recovery volume at the time of the IBP.

10.4 If the sample can be expected to demonstrate irregular boiling behavior, that is, bumping, add a few boiling chips to the specimen. The addition of a few boiling chips is acceptable for any distillation.

10.5 Fit the temperature sensor through a snug-fitting device, as described in 6.4, to mechanically center the sensor in the neck of the flask. In the case of a thermometer, the bulb is centered in the neck and the lower end of the capillary is level with the highest point on the bottom of the inner wall of the vapor tube (see Fig. 5). In the case of a thermocouple or resistance thermometer, follow the manufacturer's instructions as to placement (see Fig. 6).

NOTE 16—If vacuum grease is used on the mating surface of the centering device, use the minimum amount of grease that is practical.

10.6 Fit the flask vapor tube, provided with a snug-fitting cork or rubber stopper of silicone, or equivalent polymeric material, tightly into the condenser tube. Adjust the flask in a vertical position so that the vapor tube extends into the condenser tube for a distance from 25 to 50 mm. Raise and adjust the flask support board to fit it snugly against the bottom of the flask.

10.7 Place the receiving cylinder that was used to measure the specimen, without drying the inside of the cylinder, into its temperature-controlled bath under the lower end of the condenser tube. The end of the condenser tube shall be centered in the receiving cylinder and shall extend therein for a distance of at least 25 mm, but not below the 100-mL mark.

10.8 Initial Boiling Point:

10.8.1 *Manual Method*—To reduce evaporation loss of the distillate, cover the receiving cylinder with a piece of blotting paper, or similar material, that has been cut to fit the condenser tube snugly. If a receiver deflector is being used, start the distillation with the tip of the deflector just touching the wall of the receiving cylinder. If a receiver deflector is not used, keep

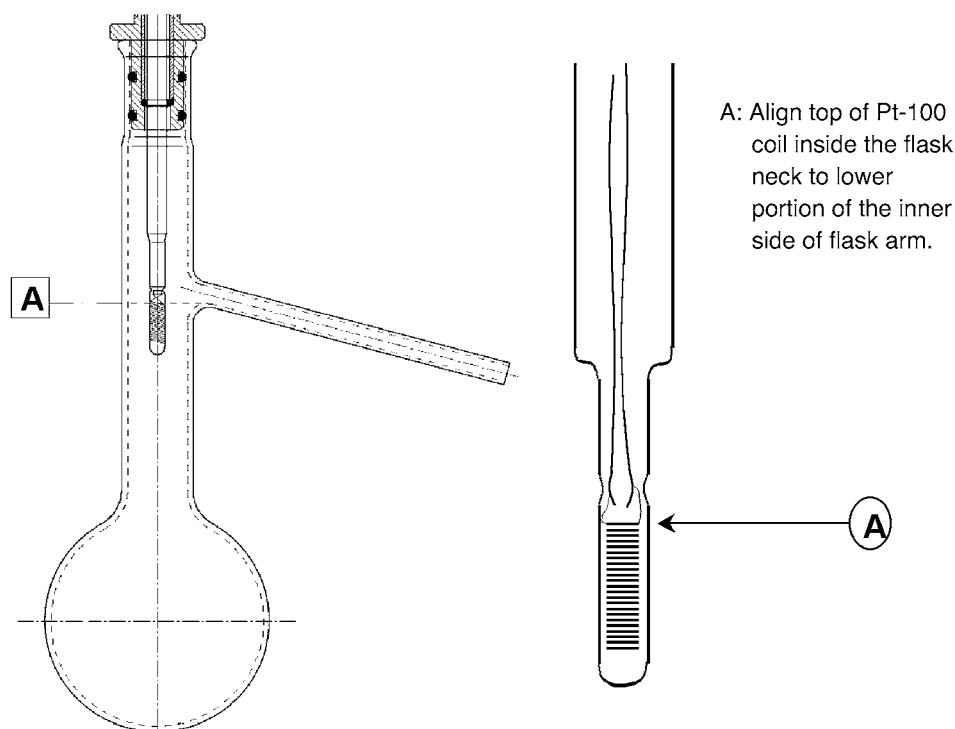

FIG. 6 Example of One Manufacturer's Recommended Placement of Pt-100 Probe Relative to Distillation Flask Sidearm for Automated D86 Distillation Instrument

the drip tip of the condenser away from the wall of the receiving cylinder. Note the start time. Observe and record the IBP to the nearest 0.5°C (1.0°F). If a receiver deflector is not being used, immediately move the receiving cylinder so that the tip of the condenser touches its inner wall.

10.8.2 *Automated Method*—To reduce evaporation loss of the distillate, use the device provided by the instrument manufacturer for this purpose. Apply heat to the distillation flask and contents with the tip of the receiver deflector just touching the wall of the receiving cylinder. Note the start time. Record the IBP to the nearest 0.1°C (0.2°F).

10.9 Regulate the heating so that the time interval between the first application of heat and the IBP is as specified in Table 5.

10.10 Regulate the heating so that the time from IBP to 5 % recovered is as indicated in Table 5.

10.11 Continue to regulate the heating so that the uniform average rate of condensation from 5 % recovered to 5 mL residue in the flask is 4 to 5 mL per min. (**Warning**—Due to the configuration of the boiling flask and the conditions of the test, the vapor and liquid around the temperature sensor are not in thermodynamic equilibrium. The distillation rate will consequently have an effect on the measured vapor temperature. The distillation rate shall, therefore, be kept as constant as possible throughout the test.)

NOTE 17—When testing gasoline samples, it is not uncommon to see the condensate suddenly form non-miscible liquid phases and bead up on the temperature measuring device and in the neck of the boiling flask at a vapor temperature of around 160°C. This may be accompanied by a sharp (about 3°C) dip in the vapor temperature and a drop in the recovery rate.

The phenomenon, which may be due to the presence of trace water in the sample, may last for 10 to 30 s before the temperature recovers and the condensate starts flowing smoothly again. This point is sometimes colloquially referred to as the Hesitation Point.

10.12 Repeat any distillation that did not meet the requirements described in 10.9, 10.10, and 10.11.

10.13 If a decomposition point is observed, discontinue the heating and proceed as directed in 10.17.

NOTE 18—Characteristic indications of thermal decomposition are evolution of fumes and erratic, typically decreasing, temperature readings that occur during the final stages of the distillation.

10.14 In the interval between the IBP and the end of the distillation, observe and record data necessary for the calculation and reporting of the results of the test as required by the specification involved, or as previously established for the sample under test. These observed data can include temperature readings at prescribed percentages recovered or percentages recovered at prescribed temperature readings, or both.

10.14.1 *Manual Method*—Record all volumes in the graduated cylinder to the nearest 0.5 mL, and all temperature readings to the nearest 0.5°C (1.0°F).

10.14.2 *Automated Method*—Record all volumes in the receiving cylinder to the nearest 0.1 mL, and all temperature readings to the nearest 0.1°C (0.2°F).

10.14.3 *Group 1, 2, 3, and 4*—In cases in which no specific data requirements have been indicated, record the IBP and the EP (FBP) or the dry point, or both, and temperature readings at 5, 15, 85, and 95 % recovered, and at each 10 % multiple of volume recovered from 10 to 90, inclusive.

TABLE 5 Conditions During Test Procedure

		Group 1	Group 2	Group 3	Group 4
Temperature of cooling bath ^A	°C	0–1	0–5	0–5	0–60
	°F	32–34	32–40	32–40	32–140
Temperature of bath around receiving cylinder	°C	13–18	13–18	13–18	±3
	°F	55–65	55–65	55–65	±5
					of charge temperature
Time from first application of heat to initial boiling point, min		5–10	5–10	5–10	5–15
Time from initial boiling point to 5 % recovered, s		60–100	60–100		
Uniform average rate of condensation from 5 % recovered to 5 mL in flask, mL/min		4–5	4–5	4–5	4–5
Time recorded from 5 mL residue to end point, min		5 max	5 max	5 max	5 max

^A the proper condenser bath temperature will depend upon the wax content of the sample and of its distillation fractions. The test is generally performed using one single condenser temperature. Wax formation in the condenser can be deduced from (a) the presence of wax particles in the distillate coming off the drip tip, (b) a higher distillation loss than what would be expected based on the initial boiling point of the specimen, (c) an erratic recovery rate and (d) the presence of wax particles during the removal of residual liquid by swabbing with a lint-free cloth (see 8.3). The minimum temperature that permits satisfactory operation shall be used. In general, a bath temperature in the 0 to 4°C range is suitable for kerosine, Grade No. 1 fuel oil and Grade No. 1-D diesel fuel oil. In some cases involving Grade No. 2 fuel oil, Grade No. 2-D diesel fuel oil, gas oils and similar distillates, it may be necessary to hold the condenser bath temperature in the 38 to 60°C range.

10.14.3.1 *Group 4*—When a high range thermometer is used in testing aviation turbine fuels and similar products, pertinent thermometer readings can be obscured by the centering device. If these readings are required, perform a second distillation in accordance with Group 3. In such cases, reading from a low range thermometer can be reported in place of the obscured high range thermometer readings, and the test report shall so indicate. If, by agreement, the obscured readings are waived, the test report shall so indicate.

10.14.4 When it is required to report the temperature reading at a prescribed percent evaporated or recovered for a sample that has a rapidly changing slope of the distillation curve in the region of the prescribed percent evaporated or recovered reading, record temperature readings at every 1 % recovered. The slope is considered rapidly changing if the change in slope (*C*) of the data points described in 10.14.2 in that particular area is greater than 0.6 (change of slope (*F*) is greater than 1.0) as calculated by Eq 1 (Eq 2).

$$\text{Change of Slope (C)} = \quad (1)$$

$$\frac{(C_2 - C_1)/(V_2 - V_1) - (C_3 - C_2)/(V_3 - V_2)}{\text{Change of Slope (F)} = \quad (2)}$$

$$\frac{(F_2 - F_1)/(V_2 - V_1) - (F_3 - F_2)/(V_3 - V_2)}$$

where:

C_1 = temperature at the volume % recorded one reading prior to the volume % in question, °C,

C_2 = temperature at the volume % recorded in question, °C,

C_3 = temperature at the volume % recorded following the volume % in question, °C,

F_1 = temperature at the volume % recorded one reading prior to the volume % in question, °F,

F_2 = temperature at the volume % recorded in question, °F,

F_3 = temperature at the volume % recorded following the volume % in question, °F,

V_1 = volume % recorded one reading prior to the volume % in question,

V_2 = volume % recorded at the volume % in question, and

V_3 = volume % recorded following the volume % in question.

10.15 When the residual liquid in the flask is approximately 5 mL, make a final adjustment of the heat. The time from the 5 mL of liquid residue in the flask to the EP (FBP) shall be within the limits prescribed in Table 5. If this condition is not satisfied, repeat the test with appropriate modification of the final heat adjustment.

NOTE 19—Since it is difficult to determine when there is 5 mL of boiling liquid left in the flask, this time is determined by observing the amount of liquid recovered in the receiving cylinder. The dynamic holdup has been determined to be approximately 1.5 mL at this point. If there are no front end losses, the amount of 5 mL in the flask can be assumed to correspond with an amount of 93.5 mL in the receiving cylinder. This amount has to be adjusted for the estimated amount of front end loss.

10.15.1 If the actual front end loss differs more than 2 mL from the estimated value, the test shall be rerun.

10.16 Observe and record the EP (FBP) or the dry point, or both, as required, and discontinue the heating.

NOTE 20—The end point (final boiling point), rather than the dry point, is intended for general use. The dry point can be reported in connection with special purpose naphthas, such as those used in the paint industry. Also, it is substituted for the end point (final boiling point) whenever the sample is of such a nature that the precision of the end point (final boiling point) cannot consistently meet the requirements given in the precision section.

NOTE 21—Groups 1 and 2, once the final heat adjustment is made, the vapor temperature/thermometer reading will continue to increase. As the distillation nears the end point (final boiling point) the distillation typically achieves dry point first. After the dry point has been achieved the vapor temperature/thermometer reading should continue to increase. The bottom of the flask will be dry but the sides and neck of the flask and the temperature sensor will still have vapor condensate present. The vapor condensate may have the appearance of a white cloud of fumes. This vapor condensate/cloud of fumes should totally engulf the temperature-measuring sensor before the vapor temperature starts to decrease. If these