

**iTeh STANDARD
PREVIEW
(standards.iteh.ai)**

[SIST ISO 7905-2:2022](https://standards.iteh.ai/catalog/standards/sist/02957c3f-658d-4da3-a2c8-d3bc9c56e3a2/sist-iso-7905-2-2022)

<https://standards.iteh.ai/catalog/standards/sist/02957c3f-658d-4da3-a2c8-d3bc9c56e3a2/sist-iso-7905-2-2022>

INTERNATIONAL
STANDARD

ISO
7905-2

Second edition
2021-12

**Plain bearings — Bearing fatigue —
Part 2:
Test with a cylindrical specimen of a
metallic bearing material**

*Paliers lisses — Fatigue des paliers —
Partie 2: Essai d'éprouvettes cylindriques en matériau antifriction
métallique*

(standards.iteh.ai)

[SIST ISO 7905-2:2022](https://standards.iteh.ai/catalog/standards/sist/02957c3f-658d-4da3-a2c8-d3bc9c56e3a2/sist-iso-7905-2-2022)

<https://standards.iteh.ai/catalog/standards/sist/02957c3f-658d-4da3-a2c8-d3bc9c56e3a2/sist-iso-7905-2-2022>



Reference number
ISO 7905-2:2021(E)

© ISO 2021

**iTeh STANDARD
PREVIEW
(standards.iteh.ai)**

[SIST ISO 7905-2:2022](https://standards.iteh.ai/catalog/standards/sist/02957c3f-658d-4da3-a2c8-d3bc9c56e3a2/sist-iso-7905-2-2022)

<https://standards.iteh.ai/catalog/standards/sist/02957c3f-658d-4da3-a2c8-d3bc9c56e3a2/sist-iso-7905-2-2022>



COPYRIGHT PROTECTED DOCUMENT

© ISO 2021

All rights reserved. Unless otherwise specified, or required in the context of its implementation, no part of this publication may be reproduced or utilized otherwise in any form or by any means, electronic or mechanical, including photocopying, or posting on the internet or an intranet, without prior written permission. Permission can be requested from either ISO at the address below or ISO's member body in the country of the requester.

ISO copyright office
CP 401 • Ch. de Blandonnet 8
CH-1214 Vernier, Geneva
Phone: +41 22 749 01 11
Email: copyright@iso.org
Website: www.iso.org

Published in Switzerland

Contents

	Page
Foreword.....	iv
1 Scope.....	1
2 Normative references.....	1
3 Terms and definitions.....	1
4 Test specimens.....	1
5 Test method.....	2
6 Evaluation and presentation of test results.....	3
Bibliography.....	4

iTeh STANDARD PREVIEW (standards.iteh.ai)

[SIST ISO 7905-2:2022](https://standards.iteh.ai/catalog/standards/sist/02957c3f-658d-4da3-a2c8-d3bc9c56e3a2/sist-iso-7905-2-2022)
<https://standards.iteh.ai/catalog/standards/sist/02957c3f-658d-4da3-a2c8-d3bc9c56e3a2/sist-iso-7905-2-2022>

ISO 7905-2:2021(E)

Foreword

ISO (the International Organization for Standardization) is a worldwide federation of national standards bodies (ISO member bodies). The work of preparing International Standards is normally carried out through ISO technical committees. Each member body interested in a subject for which a technical committee has been established has the right to be represented on that committee. International organizations, governmental and non-governmental, in liaison with ISO, also take part in the work. ISO collaborates closely with the International Electrotechnical Commission (IEC) on all matters of electrotechnical standardization.

The procedures used to develop this document and those intended for its further maintenance are described in the ISO/IEC Directives, Part 1. In particular, the different approval criteria needed for the different types of ISO documents should be noted. This document was drafted in accordance with the editorial rules of the ISO/IEC Directives, Part 2 (see www.iso.org/directives).

Attention is drawn to the possibility that some of the elements of this document may be the subject of patent rights. ISO shall not be held responsible for identifying any or all such patent rights. Details of any patent rights identified during the development of the document will be in the Introduction and/or on the ISO list of patent declarations received (see www.iso.org/patents).

Any trade name used in this document is information given for the convenience of users and does not constitute an endorsement.

For an explanation of the voluntary nature of standards, the meaning of ISO specific terms and expressions related to conformity assessment, as well as information about ISO's adherence to the World Trade Organization (WTO) principles in the Technical Barriers to Trade (TBT), see www.iso.org/iso/foreword.html.

This document was prepared by Technical Committee ISO/TC 123, *Plain bearings*, Subcommittee SC 2, *Material and lubricants, their properties, characteristics, test methods and testing conditions*.

This second edition cancels and replaces the first edition (ISO 7905-2:1995), which has been editorially revised.

The main changes compared to the previous edition are as follows:

- references to the withdrawn document ISO 468 have been replaced with references to ISO 4287.
- minor corrective amendments have been made to the test specimen diagram.

A list of all parts in the ISO 7905 series can be found on the ISO website.

Any feedback or questions on this document should be directed to the user's national standards body. A complete listing of these bodies can be found at www.iso.org/members.html.

Plain bearings — Bearing fatigue —

Part 2:

Test with a cylindrical specimen of a metallic bearing material

1 Scope

This document specifies a method for the determination of the endurance limit in fatigue of bearing materials alone (not attached to steel backing).

2 Normative references

The following documents are referred to in the text in such a way that some or all of their content constitutes requirements of this document. For dated references, only the edition cited applies. For undated references, the latest edition of the referenced document (including any amendments) applies.

ISO 4287, *Geometrical Product Specifications (GPS) — Surface texture: Profile method — Terms, definitions and surface texture parameters*

3 Terms and definitions

No terms and definitions are listed in this document.

ISO and IEC maintain terminology databases for use in standardization at the following addresses:

- ISO Online browsing platform: available at <https://www.iso.org/obp>
- IEC Electropedia: available at <https://www.electropedia.org/>

4 Test specimens

The test specimens shall be cylindrical and in accordance with [Figure 1](#).

Dimensions in millimetres

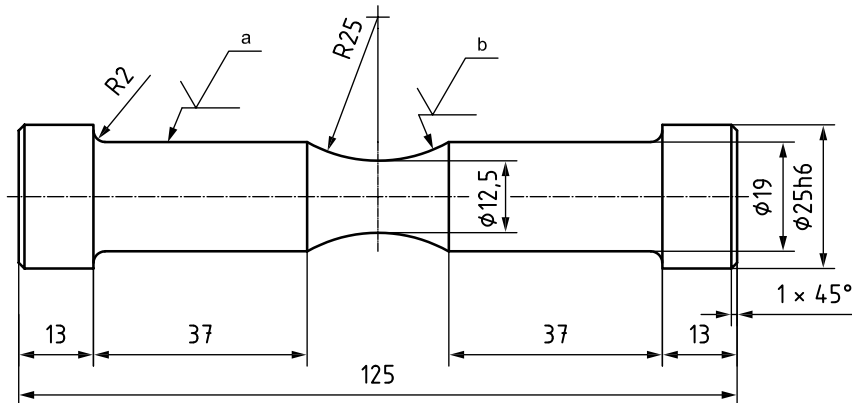

- a Polished.
- b Polished in the longitudinal direction.

Figure 1 — Specimen dimensions

The bearing material and the surface finish of the test specimen shall be as close to representative as possible to the condition caused by the manufacturing sequence used in production of the bearings. Care should be taken before and during testing not to damage the surface mechanically or by corrosion. The surface roughness shall be $R_z < 6 \mu\text{m}$ in accordance with ISO 4287. The deficiency of this test method lies in the absence of possible residual stress associated with the bearing manufacturing process and that the metallurgical structure may differ significantly from that of a thin layer applied to the steel backing of a bearing.

[SIST ISO 7905-2:2022](https://standards.iteh.ai/catalog/standards/sist/02957c3f-658d-4da3-a2c8-d3bc9c56e3a2/sist-iso-7905-2-2022)

5 Test method

<https://standards.iteh.ai/catalog/standards/sist/02957c3f-658d-4da3-a2c8-d3bc9c56e3a2/sist-iso-7905-2-2022>

In order to define the operating and lubricating conditions, the test rig shall have the following characteristics.

- The test rig should enable mounting of the specimen at each end and be able to apply an oscillating compressive/tensile load in the axial direction. An example test rig configuration is shown in [Figure 2](#).
- The load and displacement should be recorded.

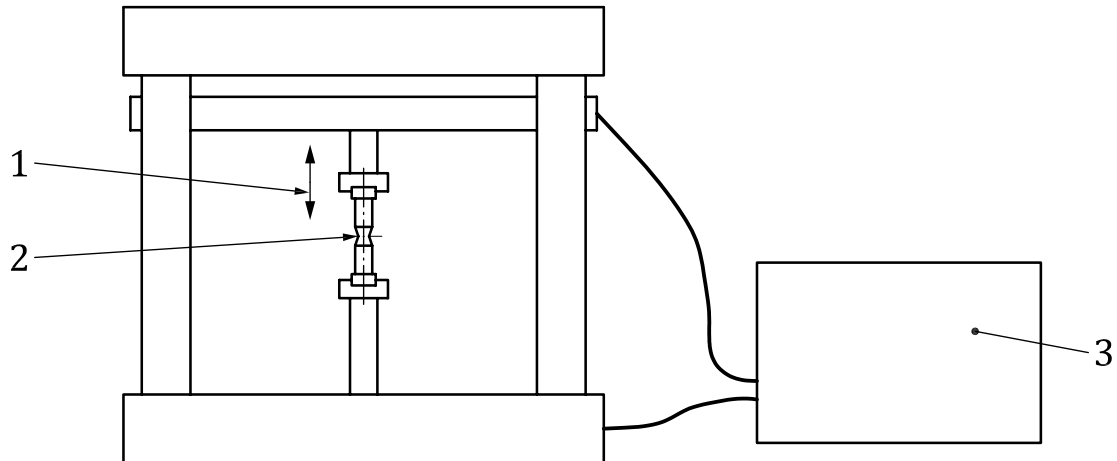
**Key**

- 1 tensile/compressive load
- 2 specimen
- 3 load control + data logging for load and displacement

Figure 2 — Example test rig configuration

The ultimate number of stress cycles is 5×10^7 . The fatigue strength for finite life shall be recorded commencing at 10^7 cycles. The test frequency shall have a range of 50 Hz to 80 Hz. In order to abridge the testing duration and to enhance the statistical estimate of fatigue life, several test rigs may be run simultaneously.

(standards.iteh.ai)

6 Evaluation and presentation of test results

The endurance limit stresses should be presented in the form of stress-number curves (Woehler curves) at predetermined temperature (± 2 °C) against a detailed description of the bearing material. Normally stress-number curve testing is terminated for practical considerations at 50×10^6 stress cycles. The endurance limit stress may be quoted at a specified number of cycles, e.g. 3×10^6 , 10×10^6 , 25×10^6 or 50×10^6 . A specimen without failure during fatigue testing to a specified endurance should be identified in the report. Due to the scatter of test results normally experienced and the statistical nature of the fatigue limit, it is recommended that the results be evaluated on the basis of a statistical method.

Another presentation of the endurance limit stress can be affected by means of a Gerber or Goodman-Haigh diagram which plots stress amplitude against mean stress. Metallographic examination will provide detailed evidence of the damage mechanism, corrosive attack and diffusion resulting from thermal effects.

Bibliography

- [1] ISO 3548-1, *Plain bearings — Thin-walled half bearings with or without flange — Part 1: Tolerances, design features and methods of test*
- [2] ISO 4378-1, *Plain bearings — Terms, definitions, classification and symbols — Part 1: Design, bearing materials and their properties*

**iTeh STANDARD
PREVIEW
(standards.iteh.ai)**

[SIST ISO 7905-2:2022](https://standards.iteh.ai/catalog/standards/sist/02957c3f-658d-4da3-a2c8-d3bc9c56e3a2/sist-iso-7905-2-2022)
<https://standards.iteh.ai/catalog/standards/sist/02957c3f-658d-4da3-a2c8-d3bc9c56e3a2/sist-iso-7905-2-2022>