



Standard Test Method for Dust-and-Fog Tracking and Erosion Resistance of Electrical Insulating Materials¹

This standard is issued under the fixed designation D2132; the number immediately following the designation indicates the year of original adoption or, in the case of revision, the year of last revision. A number in parentheses indicates the year of last reapproval. A superscript epsilon (ϵ) indicates an editorial change since the last revision or reapproval.

1. Scope

1.1 This test method is intended to differentiate solid electrical insulating materials with respect to their resistance to the action of electric arcs produced by conduction through surface films of a specified contaminant containing moisture. Test Methods D2302 and D2303 ~~may also be used to evaluate materials.~~ are also useful to evaluate materials.

1.2 The values stated in inch-pound units are the standard, except in cases where SI units are more appropriate. The values in parentheses are for information only.

1.3 *This standard does not purport to address all of the safety concerns, if any, associated with its use. It is the responsibility of the user of this standard to establish appropriate safety and health practices and determine the applicability of regulatory limitations prior to use.* Specific precautionary statements are given in 12.4.

NOTE 1—There is no equivalent ISO standard.

2. Referenced Documents

2.1 *ASTM Standards:*²

D709 [Specification for Laminated Thermosetting Materials](#)

D1711 [Terminology Relating to Electrical Insulation](#)

D2302 [Method of Test for Differential Wet Tracking Resistance of Electrical Insulating Materials with Controlled Water-to-Metal Discharges](#)³

D2303 [Test Methods for Liquid-Contaminant, Inclined-Plane Tracking and Erosion of Insulating Materials](#)

3. Terminology

3.1 *Definitions:*

3.1.1 For definitions pertinent to this test method see Terminology D1711.

4. High Voltage Hazard

4.1 Lethal voltages are a potential hazard during the performance of this test. It is essential that the test apparatus, and all associated equipment electrically connected to it, be properly designed and installed for safe operation.

4.2 Solidly ground all electrically conductive parts which it is possible for a person to contact during the test.

4.3 Provide means for use at the completion of any test to ground any parts which were at high voltage during the test or have the potential for acquiring an induced charge during the test or retaining a charge even after disconnection of the voltage source.

4.4 Thoroughly instruct all operators as to the correct procedures for performing tests safely.

4.5 When making high voltage tests, particularly in compressed gas or in oil, it is possible for the energy released at breakdown to be sufficient to result in fire, explosion, or rupture of the test chamber. Design test equipment, test chambers, and test specimens so as to minimize the possibility of such occurrences and to eliminate the possibility of personal injury.

NOTE 2—~~If the potential for fire exists, have fire suppression equipment available. See section 12.~~

¹ This test method is under the jurisdiction of ASTM Committee D09 on Electrical and Electronic Insulating Materials and is the direct responsibility of Subcommittee D09.18 on Solid Insulations, Non-Metallic Shieldings and Coverings for Electrical and Telecommunication Wires and Cables.

~~Current edition approved April 15, 2011. Published June 2011. Originally approved in 1962. Last previous edition approved in 2003 as D2132-03. DOI: 10.1520/D2132-11.~~

Current edition approved Jan. 1, 2012. Published February 2012. Originally approved in 1962. Last previous edition approved in 2011 as D2132-11. DOI: 10.1520/D2132-12.

² For referenced ASTM standards, visit the ASTM website, www.astm.org, or contact ASTM Customer Service at service@astm.org. For *Annual Book of ASTM Standards* volume information, refer to the standard's Document Summary page on the ASTM website.

³ Withdrawn. The last approved version of this historical standard is referenced on www.astm.org.

5. Summary of Test Method

5.1 With electrodes mounted as shown in Fig. 1, coat test specimens with a synthetic dust and test in a chamber shown in Fig. 2. Direct a water spray at the test specimen. After the surface has been wetted, apply a 60-Hz voltage between the electrodes. Arcing occurs across localized high-resistance areas produced by nonuniform evaporation of the water from the contaminant. These arcs produce high temperatures in the underlying insulation with resultant carbonization of most organic materials. The carbonization concentrates the electric field. Further, it is possible further carbonization can occur in the direction of the field. In such cases, a carbon track is formed which spans the distance between the electrodes and causes failure. Materials that do not track can erode under the action of the arcing. Such erosion usually progresses from an upper electrode through the thickness of the specimen towards the underlying electrode.

5.2 Rate materials that track in terms of the time required to form a track between the electrodes.

5.3 Rate materials that do not track in terms of the time required to erode to failure.

5.4 Failure will be indicated when the current increases sufficiently to actuate an overcurrent device.

NOTE 2—The conditions of this test favor the formation of a track for several possible reasons. Most important, the continuous renewal of the conducting properties of the contaminant by the water spray allows a track to grow progressively over long periods of time.

6. Significance and Use

6.1 Method—It is possible that electrical insulation in service can fail as a result of tracking, erosion, or a combination of both, if exposed to high relative humidity and contamination environments. This is particularly true of organic insulations in outdoor applications where the surface of the insulation becomes contaminated by deposits of moisture and dirt, for example, coal dust or salt spray. This test method is an accelerated test that simulates extremely severe outdoor contamination. It is believed that the most severe conditions likely to be encountered in outdoor service in the United States will be relatively mild compared to the conditions specified in this test method.

6.2 Test Results—Materials can be classified by this test method as tracking-resistant, tracking-affected, or tracking-susceptible. The exact test values for these categories as they apply to specific uses will be specified in the appropriate material specifications, but guideline figures are suggested in Note 3. Tracking-resistant materials, unless erosion failure occurs first, can last many hundreds of hours (Note 4). Erosion, though it can progress laterally, generally results in a failure perpendicular to the specimen surface. Therefore, only specimens of the same nominal thickness can be compared for resistance to tracking-induced erosion. The extent of erosion can be estimated from measurements of the depth of penetration of the erosion. Materials that are not tracking-susceptible can be placed in three broad categories—erosion-resistant, erosion-affected, and erosion-susceptible. When the standard thickness specimen is tested, the following times to failure typify the categories. Tracking-resistant materials, unless erosion failure occurs first, have the potential to last many hundreds of hours (Note 5). Erosion, though it is possible that it will progress laterally, generally results in a failure perpendicular to the specimen surface. Therefore, compare only specimens of the same nominal thickness for resistance to tracking-induced erosion. Estimate the extent of erosion from measurements of the depth

<https://standards.iteh.ai/catalog/standards/sist/cec2491e-433f-40a0-994c-0039251aab5f/astm-d2132-12>

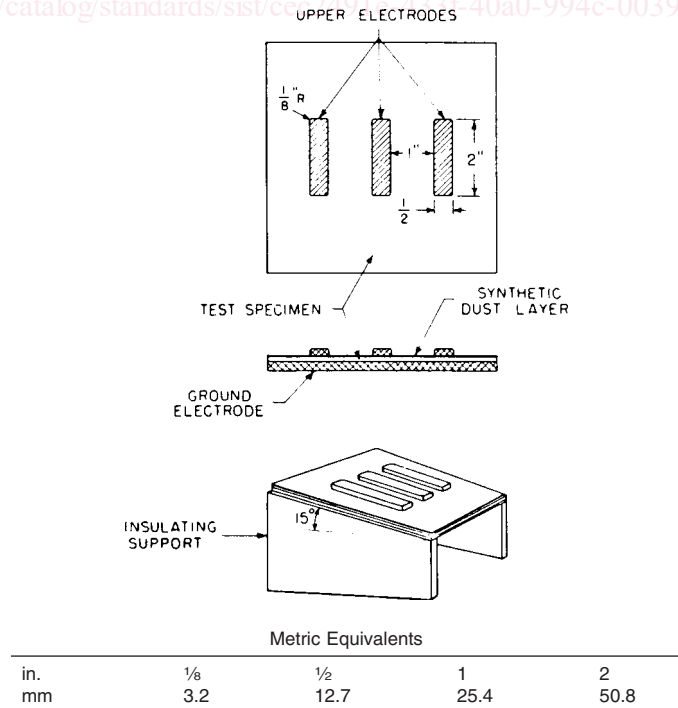

FIG. 1 Test Arrangement of Electrode System

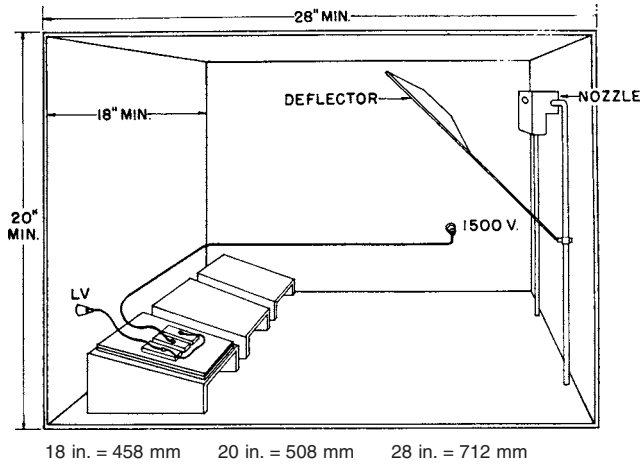

FIG. 2 Dust and Fog Test Chamber, Minimum Recommended Size

of penetration of the erosion. Place materials that are not tracking-susceptible in three broad categories—erosion-resistant, erosion-affected, and erosion-susceptible. When the standard thickness specimen is tested, the following times to failure typify the categories (Note 6):

Erosion-susceptible	5 to 50 h
Erosion-affected	50 to 200 h
Erosion-resistant	over 200 h

NOTE 34—Tracking-susceptible materials usually fail within 5 h. Tracking-affected materials usually fail before about 100 h.

NOTE 4—This 5—This information is derived from the individual experiences of eight laboratories using this test method since its publication as a suggested test method in June 1957, and from the results of an organized test program among these laboratories.

NOTE 5—In 6—In a normal distribution approximately 68 % of all test values are included within ± 1 standard deviation of the mean.

6.3 Interpretation of Test Results—This test method provides information that allows classification as described in 6.2. The comparison of materials within the same group is likely to be ambiguous unless three or more replicate specimens are tested. When the test method is used for specification purposes, simple minimum values should not be established do not establish simple minimum values without consideration of the large variance to be expected in test results. It is recommended that quality levels and specification minima be determined by statistical techniques.

7. Apparatus

7.1 General—A schematic diagram of the power supply and control apparatus for testing one specimen is shown in Fig. 3(a). It is generally desirable to test three or more specimens simultaneously. It is recommended but not mandatory that a separate power supply and control be used for each test specimen. This allows “breaking-in” and recording of time to failure separately for each specimen.

7.2 Circuit Breaker—The circuit breaker (current relay, OL) interrupts the power supply on failure and stops the timing meter. It can be used Use it as an ON-OFF switch and as a device for interrupting air and water supply when all specimens fail. Fig. 3(b) illustrates the air and water supply circuit when three specimens are tested using one fog nozzle. The circuit breaker shall be rated at 2 to 3 A, inverse-time element type, for a 115-V supply. Use a resistance, R_0 , to shunt the current coil during the break-in period

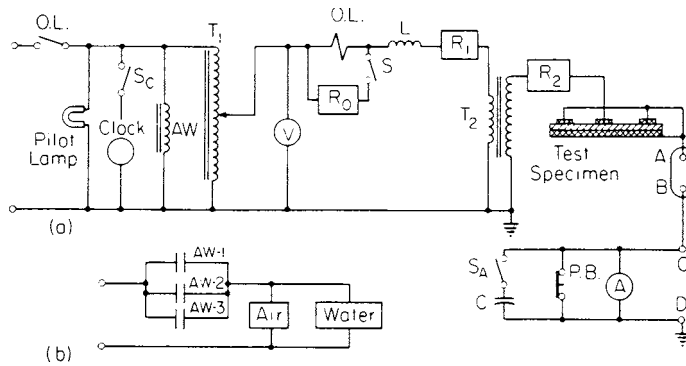

(a) Power supply and control circuit of wet tracking tests.
(b) Air and water supply circuit.

FIG. 3 Circuit Diagrams