



~~Designation: C1242-11~~ Designation: C1242 - 12

Standard Guide for Selection, Design, and Installation of Dimension Stone Attachment Systems¹

This standard is issued under the fixed designation C1242; the number immediately following the designation indicates the year of original adoption or, in the case of revision, the year of last revision. A number in parentheses indicates the year of last reapproval. A superscript epsilon (ϵ) indicates an editorial change since the last revision or reapproval.

INTRODUCTION

Natural building stone is chosen as a building's cladding for its beauty which endures with minimal maintenance. Stone is durable when used properly. Exercising good judgment when selecting the particular stone, determining the quarrying and fabrication techniques, designing the method of attachment, and installing all components correctly maximizes these benefits. A properly executed stone cladding is designed and installed within the capabilities and limitations of the stone and support system to resist all forces that work on them.

This guide presents design principles that require consideration when designing anchorages and evaluating exterior stone to be compatible with its proposed use. It is an overview of current techniques and a review of minimum requirements for sound stone engineering and construction. The guide does not list all possible methods of attachment nor does it provide a step-by-step procedure for stone anchor engineering. Knowledge gained from new engineering designs, testing of applications, and the investigation of existing problems are continually reviewed to update this guide. Comment from users is encouraged.

Good judgment by architects, engineers, and contractors when specifying, designing, engineering, and constructing stone and other work that interfaces stone is necessary to use this guide. Users of this guide should combine known performance characteristics of the stone, the building's structural behavior, and knowledge of materials and construction methods with proven engineering practice.

1. Scope

1.1 This guide covers the categories of anchors and anchoring systems and discusses the design principles to be considered in selecting anchors or systems that will resist gravity loads and applied loads.

1.2 This guide sets forth basic requirements for the design of stone anchorage and provides a practical checklist of those design considerations.

1.3 This guide pertains to:

1.3.1 The anchoring of stone panels directly to the building structure for support,

1.3.2 The anchoring of stone panels to subframes or to curtainwall components after these support systems are attached to the building structure,

1.3.3 The anchoring of stone panels to subframes or to curtainwall components with stone cladding preassembled before these support systems are attached to the building structure, and

1.3.4 The supervision and inspection of fabrication and installation of the above.

1.4 Observe all applicable regulations, specific recommendations of the manufacturers, and standards governing interfacing work.

1.5 The values stated in inch-pound units are to be regarded as standard. The values given in parentheses are mathematical conversions to SI units that are provided for information only and are not considered standard.

1.6 *This standard does not purport to address all of the safety concerns, if any, associated with its use. It is the responsibility of the user of this standard to establish appropriate safety and health practices and determine the applicability of regulatory limitations prior to use. (See Tables 1 and 2.)*

¹ This guide is under the jurisdiction of ASTM Committee C18 on Dimension Stone and is the direct responsibility of Subcommittee C18.06 on Attachment Components and Systems.

Current edition approved Aug. 1, 2011, 2012. Published September 2011/February 2012. Originally approved in 1993. Last previous edition approved in 2010/2011 as C1242 - 10/1. DOI: 10.1520/C1242-142.

2. Referenced Documents

2.1 ASTM Standards:²

- C97 Test Methods for Absorption and Bulk Specific Gravity of Dimension Stone
- C99 Test Method for Modulus of Rupture of Dimension Stone
- C119 Terminology Relating to Dimension Stone
- C170 Test Method for Compressive Strength of Dimension Stone
- C406 Specification for Roofing Slate
- C482 Test Method for Bond Strength of Ceramic Tile to Portland Cement Paste
- C503 Specification for Marble Dimension Stone
- C568 Specification for Limestone Dimension Stone
- C615 Specification for Granite Dimension Stone
- C616 Specification for Quartz-Based Dimension Stone
- C629 Specification for Slate Dimension Stone
- C880 Test Method for Flexural Strength of Dimension Stone
- C1193 Guide for Use of Joint Sealants
- C1201 Test Method for Structural Performance of Exterior Dimension Stone Cladding Systems by Uniform Static Air Pressure Difference
- C1354 Test Method for Strength of Individual Stone Anchorages in Dimension Stone
- C1496 Guide for Assessment and Maintenance of Exterior Dimension Stone Masonry Walls and Facades
- C1526 Specification for Serpentine Dimension Stone
- C1527 Specification for Travertine Dimension Stone
- E632 Practice for Developing Accelerated Tests to Aid Prediction of the Service Life of Building Components and Materials

3. Terminology

- 3.1 *General Definitions*—For definitions of terms used in this guide, refer to Terminology C119.
- 3.2 Specific definitions used in the design process are listed in 8.4.

4. Significance and Use

- 4.1 This guide is intended to be used by architects, engineers, and contractors who either design or install exterior stone cladding for architectural structures.
- 4.2 This guide is an industry standard for engineering design considerations, documentation, material considerations, anchor type applications, and installation workmanship to assist designers and installers to achieve a proper and durable stone cladding.
- 4.3 Stone and its support systems are part of a building's skin and shall be compatible with the behavior and performance of other interfacing systems, such as the curtainwall and superstructure frame.
 - 4.3.1 Every stone work application shall comply with applicable building codes.
 - 4.3.2 It is not the intent of this Guide to supersede published recommendations for specific stone types. Provisions of other dimension stone industry publications should be reviewed and considered in addition to this Guide's recommendations. All industry information should be considered with respect to project specifications and requirements. If provisions of such

² For referenced ASTM standards, visit the ASTM website, www.astm.org, or contact ASTM Customer Service at service@astm.org. For *Annual Book of ASTM Standards* volume information, refer to the standard's Document Summary page on the ASTM website.

TABLE 1 Dimension Stone Specifications

Stone Type	ASTM Specification
Calcite ^A	C503
Dolomite ^A	C503
Granite	C615
Limestone ^B	C568
Marble (exterior) ^B	C503
Quartz-Based ^B	C616
Quartzite ^A	C616
Quartzitic Sandstone ^A	C616
Sandstone ^A	C616
Serpentine ^A	C503
Serpentine	C1526
Slate (roof)	C406
Slate (walls)	C629
Travertine ^A	C1527

^A This stone type is a subclassification.
^B This stone type has subclassifications or grades.

TABLE 2 Dimension Stone Test Methods

Measures	ASTM Test Method
liquid porosity and relative density	C97
combined shear with tensile unit strength from bending	C99
ultimate crushing unit strength	C170
primary tensile unit strength from bending	C880
capacity and deflections of panels assembled with their anchors onto their supporting backup structure	C1201
individual anchor strength	C1354
accelerated production of service life	E632

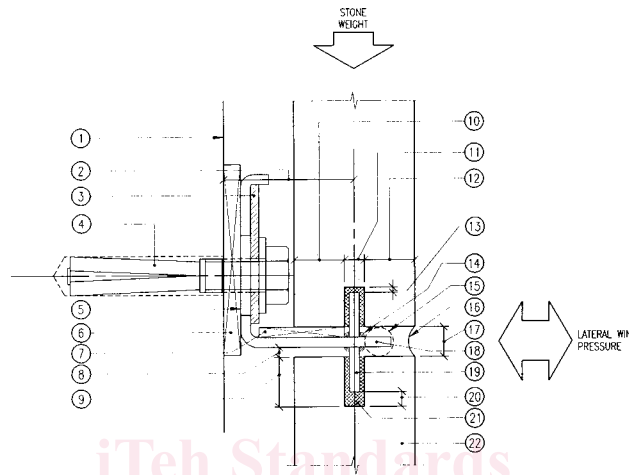

ANCHOR IN HORIZONTAL JOINT CAN SUPPORT GRAVITY AND LATERAL LOADS (FIGURE AS SECTION VIEW)
 ANCHOR IN VERTICAL JOINT CAN SUPPORT ONLY LATERAL LOADS (FIGURE AS PLAN VIEW)

- 1 SUPPORT ANCHORAGE ON COMPATIBLE, STABLE BACKUP.
- 2 MINIMIZE DISTANCE TO MINIMIZE ECCENTRIC WEIGHT ON ANCHORAGE AND TO REDUCE FASTENER (PART 4) PULLOUT AND SUPPORT ANGLE (PART 17) DISPLACEMENT. ALLOW FOR FABRICATION, CONSTRUCTION AND INSTALLATION TOLERANCES.
- 3 PREVENT SLIP OF THE CONNECTION AFTER VERTICAL ADJUSTMENT WITH DIAGONALLY SLOTTED WASHER PLATE, WELD WASHER WITH WELD, OR SERRATED ANCHOR AND WASHER. DO NOT RELY ON FRICTION.
- 4 ATTACH ANCHOR WITH FASTENER TO BACKUP.
- 5 USE HORIZONTAL SLOT TO ALIGN DOWEL WITH HOLE. VERTICAL SLOT TO ALLOW FOR HEIGHT ADJUSTMENT AND FASTENER PLACEMENT.
- 6 PLACE PLASTIC OR METAL ADJUSTMENT BEARING SHIM SLIGHTLY LARGER THAN ANCHOR'S FASTENED FACE. REQUIRED TO SEPARATE AND ADJUST POSITION OF ANCHOR RELATIVE TO FRAMING. MINIMIZE THICKNESS TO MINIMIZE BENDING ON FASTENER (PART 4). THICKNESS AFFECTS FASTENER (PART 4) CAPACITY.
- 7 PLACE PLASTIC OR STIFF RUBBER BEARING SHIM FOR LEVELING, SEPARATION, AND TO PREVENT BEARING OF STONE ON DOWEL WELD. ADJUST ANCHOR VERTICALLY WITH PART 3, NOT SHIMS.
- 8 MAINTAIN CLEARANCE TO AVOID CONTACT AND WEIGHT TRANSFER (UNLESS DESIGNED TO STACK). ALLOW FOR MOVEMENT, CREEP, EXPANSION, AND FABRICATION AND INSTALLATION TOLERANCES.
- 9 MINIMIZE HOLE DEPTH, INCLUDING VARIANCES PER PART 20, MAINTAIN 3/8 IN. (10mm) ENGAGEMENT OR TESTED MINIMUM. GREATER ENGAGEMENT DOES NOT NECESSARILY INCREASE ANCHOR CAPACITY.
- 10 VERIFY INTERIOR EDGE DISTANCE. STONE HERE RESISTS NEGATIVE (OUTWARD AND SUCTION) PRESSURE. MAINTAIN SUFFICIENT WIDTH FROM MINIMUM PANEL THICKNESS.
- 11 LOCATE HOLE IN CENTER THIRD OF PANEL THICKNESS. MINIMIZE DIAMETER TO MAXIMIZE EDGE DISTANCE (PARTS 10 AND 12).
- 12 VERIFY EXTERIOR EDGE DISTANCE. STONE HERE RESISTS POSITIVE (INWARD) PRESSURE. KEEP THIS DIMENSION CONSTANT FROM OUTSIDE FACE TO KEEP PANEL FACES ALIGNED.
- 13 MAINTAIN CLEARANCE TO AVOID POINT LOADING ON DOWEL END. DIMENSION TO EQUAL OR EXCEED PART 7.
- 14 WELD AT FIXED DOWEL. MINIMUM DIAMETER HOLE ONLY FOR CLEARANCE AT DROP (LOOSE) DOWEL.
- 15 BOND BREAKER AT ANCHOR AND BACKER ROD BEYOND TO PREVENT THREE SIDED SEALANT BOND.
- 16 FILL JOINTS BETWEEN PANELS WITH COMPRESSIBLE GASKET OR SEALANT WITH PROPER PROFILE AND COMPATIBILITY.
- 17 SIZE JOINTS TO ALLOW FOR HARDWARE, TOLERANCES, CLEARANCES, APPROPRIATE MOVEMENT, AND JOINT FILLER CAPABILITY. ISOLATE DYNAMIC BUILDING MOVEMENTS FROM THIS TYPE OF ANCHOR.
- 18 CONNECT DOWEL TO BACKUP WITH METAL LATERAL AND GRAVITY SUPPORT ANGLE (BRAKE-FORMED SHAPED SHOWN). CAN ALSO BE ROLLED OR EXTRUDED SHAPE.
- 19 ENGAGE PANEL EDGE WITH A FIXED OR DROP (LOOSE) METAL DOWEL AND DOWEL MISALIGNMENT IN HOLE AND RESULTING PRYING ON STONE PANEL.
- 20 MAINTAIN CLEARANCE TO AVOID POINT LOADING ON DOWEL ENDS. DIMENSION TO EQUAL OR EXCEED PART 8. DO NOT ALLOW FLOOR-TO-FLOOR MOVEMENTS TO OCCUR IN THE HOLES.
- 21 FILL HOLES WITH COMPRESSIBLE MATERIAL TO PREVENT MOISTURE ACCUMULATION, TO FIX POSITION, AND TO CUSHION BEARING OF DOWEL ON SIDES OF HOLE. WAX, GREASE, WRAP TAPE ON DOWEL OR BED A SLEEVE FOR THE DOWEL TO SLIDE ON WHERE ADHESION IS NOT DESIRED.
- 22 DIMENSION STONE CLADDING FACE PANEL.

FIG. 1 Dowel Anchor

publications differ from those in this Guide, it is acceptable practice to follow the publication's provisions if recommended by the stone specialist defined in 4.4 for the specific conditions of the individual project.

4.3.3 Because stone properties vary, the range and variability of pertinent properties of the stone proposed for use should be determined by testing and statistical methods that are evaluated using sound engineering principles. Use recent test data where applicable. Always reference proven performance of relevant existing structures.

4.3.4 Changes in properties over time shall be considered.

4.3.5 Overall behaviors of all building systems and components including the stone shall be interactively compatible.

4.4 *Stone Specialist*—Some conditions require professional expertise to select and plan a proper anchoring system, establish appropriate testing requirements, interpret tests, design and engineer the anchoring system, or monitor its fabrication and

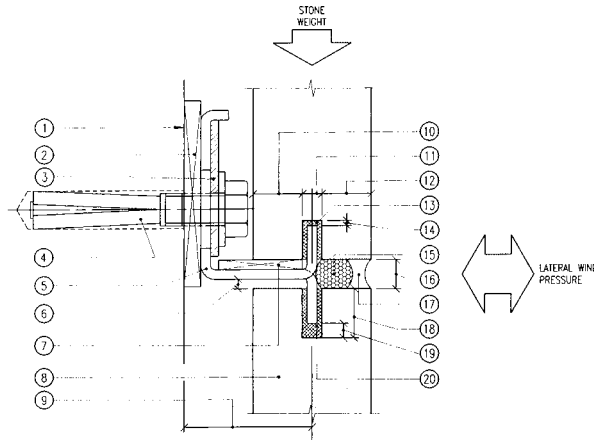

ANCHOR IN HORIZONTAL JOINT CAN SUPPORT GRAVITY AND LATERAL LOADS (FIGURE AS SECTION VIEW)
 ANCHOR IN VERTICAL JOINT CAN SUPPORT ONLY LATERAL LOADS (FIGURE AS PLAN VIEW)

- | | |
|--|--|
| <ul style="list-style-type: none"> ① SUPPORT ANCHORAGE ON COMPATIBLE, STABLE BACKUP. ② PLACE PLASTIC OR METAL ADJUSTMENT BEARING SHIM SLIGHTLY LARGER THAN ANCHOR'S FASTENED FACE. REQUIRED TO SEPARATE DISSIMILAR MATERIALS AND ADJUST TO FRAMING. MINIMIZE THICKNESS TO MINIMIZE BENDING ON FASTENER (PART 4). ③ PREVENT SIP OF THE CONNECTION AFTER VERTICAL ADJUSTMENT WITH DIAGONALLY SLOTTED WASHER PLATE, WELD WASHER WITH WELD, OR SERRATED ANCHOR AND WASHER. DO NOT RELY ON FRICTION. ④ ATTACH ANCHOR WITH FASTENER TO BACKUP. ⑤ KERF ANCHOR: (BRAKE-FORMED SPLIT-EAR SHAPE SHOWN) OR EXTRUDED SHAPE THAT FITS INTO SAWN KERF. AVOID MISALIGNMENT AND RESULTING PRYING ON KERF FROM INACCURATE FABRICATION OR INSTALLATION. SHOULD NOT BE CONTINUOUS ACROSS PANEL JOINTS. CAPACITY OF CONNECTION IS NOT DIRECTLY PROPORTIONAL TO ANCHOR LENGTH. ⑥ MAINTAIN CLEARANCE TO AVOID CONTACT AND WEIGHT TRANSFER (UNLESS DESIGNED TO STACK). ALLOW FOR MOVEMENT, CREEP, EXPANSION, AND FABRICATION AND INSTALLATION TOLERANCES. ⑦ PLACE PLASTIC OR STIFF RUBBER BEARING SHIM FOR LEVELING, SEPARATION, AND TO PREVENT BEARING OF STONE KERF FIN ON ANCHOR RADIUS. ADJUST ANCHOR VERTICALLY WITH PART 3, NOT SHIMS. ⑧ DIMENSION STONE CLADDING FACE PANEL. ⑨ MINIMIZE DISTANCE TO MINIMIZE ECCENTRIC WEIGHT ON ANCHOR - REDUCES FASTENER (PART 4) PULLOUT AND SUPPORT ANCHOR (PART 5) DISPLACEMENT. ⑩ VERIFY INTERIOR KERF FIN. STONE HERE RESISTS NEGATIVE (OUTWARD OR SUCTION) PRESSURE. MAINTAIN SUFFICIENT WIDTH FROM MINIMUM PANEL THICKNESS. | <ul style="list-style-type: none"> ⑪ LOCATE CONTINUOUS OR INTERMITTENT SAWCUT KERF IN CENTER THIRD OF THICKNESS. CONTROL WIDTH TO ALLOW TOLERANCE WITH KERF ANCHOR. MINIMIZE WIDTH TO MAXIMIZE EDGE DISTANCES (PARTS 10 AND 12). ⑫ VERIFY EXTERIOR KERF FIN. (3/8 IN. (10mm) MINIMUM) STONE HERE RESISTS POSITIVE (INWARD) PRESSURE. KEEP THIS DIMENSION CONSTANT TO KEEP STONE FACES ALIGNED. ⑬ FILL KERF IN BOTTOM EDGE OF STONE ONLY AT ANCHORS WITH SEALANT TO SET POSITION AND TO CUSHION BEARING. ⑭ MAINTAIN CLEARANCE TO AVOID POINT LOADING AT TOP AND BOTTOM. DIMENSION TO EQUAL OR EXCEED PART 6. DO NOT ALLOW FLOOR-TO-FLOOR MOVEMENTS TO OCCUR IN THE KERF. ⑮ PLACE BACKER ROD OR FOAM TAPE AT PROPER DEPTH TO PREVENT THREE-SIDED SEALANT BOND. ⑯ SIZE JOINTS TO ALLOW FOR HARDWARE, TOLERANCES, CLEARANCES, APPROPRIATE MOVEMENT, AND JOINT FILLER CAPABILITY. ISOLATE DYNAMIC BUILDING MOVEMENTS FROM THIS TYPE OF ANCHOR. ⑰ FILL JOINTS BETWEEN PANELS WITH COMPRESSIBLE GASKET OR SEALANT WITH PROPER PROFILE AND COMPATIBILITY. ⑱ MINIMIZE KERF DEPTH TO MINIMIZE PRYING AND MAXIMIZE CAPACITY. MAINTAIN 3/8 IN. (10mm) MINIMUM OR TESTED MINIMUM ENGAGEMENT. ⑲ MAINTAIN CLEARANCE TO AVOID POINT LOADING AT KERF IN TOP OF STONE. DIMENSION TO EQUAL OR EXCEED PART 6. DO NOT ALLOW DYNAMIC DISPLACEMENTS TO OCCUR IN THE KERF. ⑳ FILL KERF IN TOP EDGE OF STONE CONTINUOUSLY WITH SEALANT TO TOP OF KERF TO PREVENT MOISTURE ACCUMULATION, SET POSITION, AND CUSHION BEARING OF ANCHOR ON SIDES OF KERF. |
|--|--|

FIG. 2 Kerf Anchor

installation. A specialist is a person that complements the capabilities of the project team by contributing specific expert experience with the use, selection, design, and installation of dimension stone.

4.4.1 Particular conditions where special expertise is suggested to achieve a reliable installation:

- 4.4.1.1 Where complex connections or anchoring methods of unknown or questionable performance records are likely to be considered or specified;
- 4.4.1.2 Where the performance record of the specified systems and materials is not known or questionable;
- 4.4.1.3 When multiple cladding materials occur on the same facade;
- 4.4.1.4 If the supporting structure or backup is more flexible than $L/600$ in any direction;
- 4.4.1.5 If extreme loading could be caused by seismic, hurricane, tornado, or installation and handling methods;
- 4.4.1.6 When special building code requirements prevail.
- 4.4.1.7 If provisions of stone industry publications or project specifications differ from this guide.

5. Installation Standards

5.1 *Documentation*—The basis for standard workmanship shall be established in the design documents issued to describe, regulate, or control the construction. These documents may be issued by the architect, engineer, the design-build authority, the contractor, or others authorized to impose law or code. Examples are as follows:

5.1.1 The architectural drawings and specifications identifying stone type, finish, thickness, sizes, and details and the relationship to other architectural elements and the building structure.

5.1.2 The architectural drawings and specifications identifying the scope of work and the materials required. These may: (1) define the performance criteria to be satisfied, (2) specify the standards of performance to be used in meeting those criteria, (3)

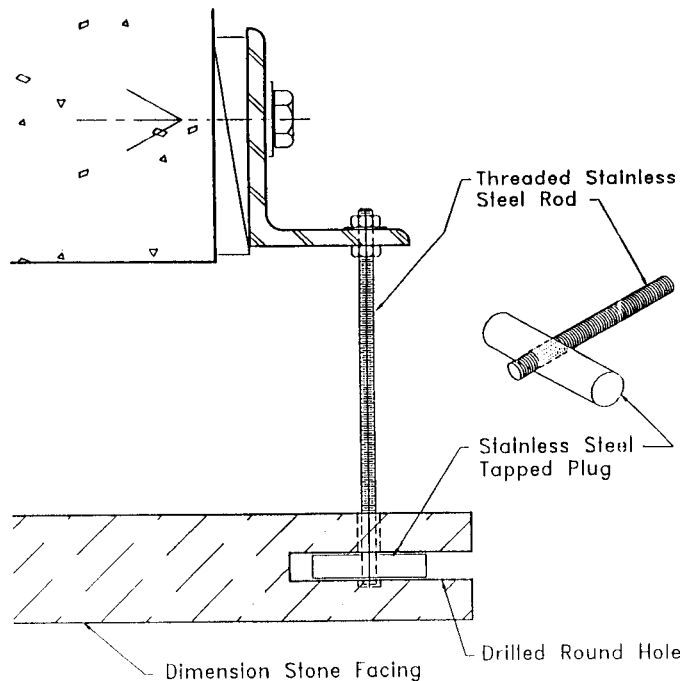

FIG. 3 Rod and Plug Anchor

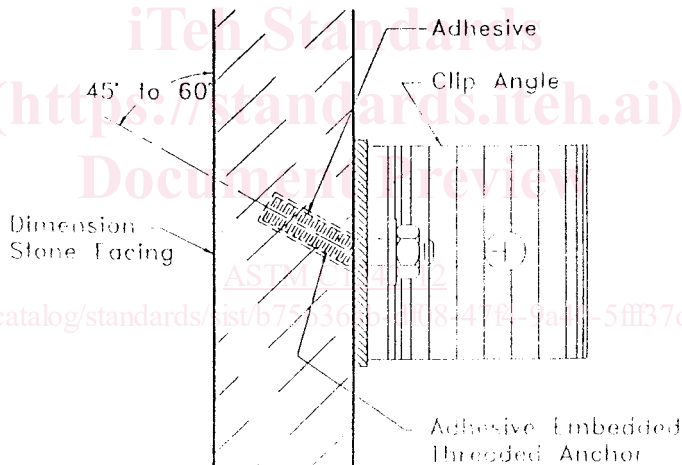

FIG. 4 Adhesive Embedded Threaded Anchor

provide for adequate performance guarantees for the materials and methods of construction, and (4) prescribe definitive material details and systems to satisfy project requirements. In addition, the specifications shall establish stone fabrication and installation tolerances. The tolerances recommended by stone trade associations could be used as a guide and included in the specification.

5.1.3 Project specifications shall cite the ASTM standard material specification (see 2.1) governing the stone intended for use and identify the classification or grade within that standard specification.

5.1.4 Shop drawings indicating in detail all parts of the work required, including material types, thicknesses, finishes and all other pertinent information dealing with fabrication, anchorage, and installation. The drawings shall show contiguous materials or assemblies which are provided by others in their range of positions according to their specified tolerances.

5.2 *Tolerances*—Installation tolerances and requirements, once specified, bind the installation contractor, by contract, to perform the work within those specified tolerances. The specification requires the installation contractor to progressively examine the construction to which his work attaches or adjoins, reporting to the prime contractor any condition that may prevent performance within the standard established. Some commonly specified installation tolerances follow:

5.2.1 Variation from plumb of wall surfaces, arises, external corners, joints, and other conspicuous lines should not exceed 1/4 in. (6.4 mm) in any story or in 20 ft (6.1 m) maximum.

5.2.2 Variation in level from grades shown for horizontal joints and other conspicuous lines should not exceed 1/4 in. in 20 ft (6.4 mm in 6.1 m) maximum, nor 3/4 in. in 40 ft (19.1 mm in 12.2 m) or more.

5.2.3 Variation in linear building lines from positions shown on drawings and related portion of wall facing should not exceed

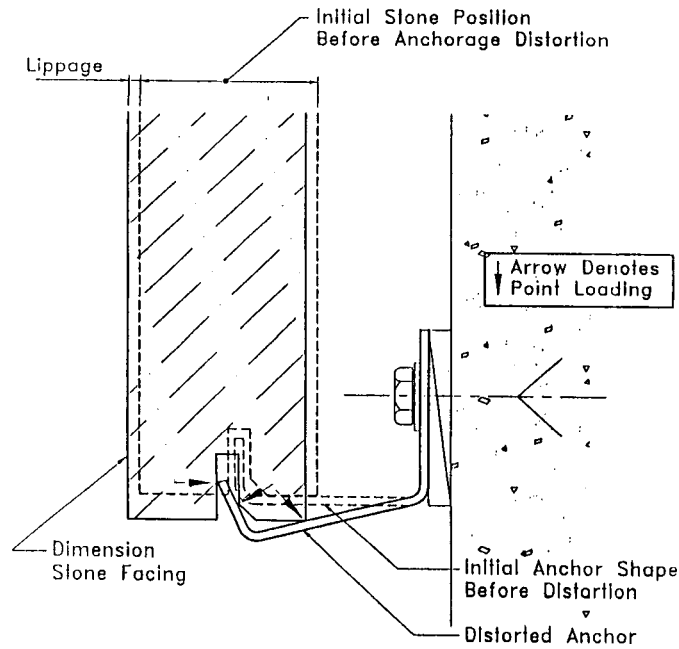

FIG. 5 Point Loading Prevention

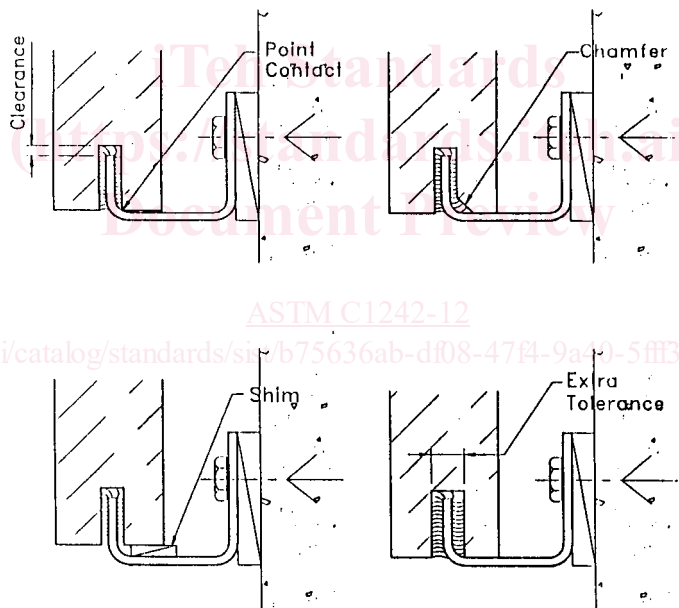

FIG. 5 Point Loading Prevention (continued) (continued)

1/2 in. (12.7 mm) in any bay or 20 ft (6.1 m) maximum, nor 3/4 in. in 40 ft (19.1 mm in 12.2 m) or more.

5.2.4 Variation in the face plane of adjacent pieces (lippage) should not exceed one fourth of the width of the joint between the pieces up to but not more than 1/16 in. (1.5 mm) unless panel finish is not smooth or panel size exceeds 20 ft²(1.8 mm²).

5.3 *Workmanship*—Good construction requires mechanics that have previous successful experience installing similar stonework to do the new work. Less experienced personnel can only be allowed when they work in a crew continuously with the mechanic who has previous successful experience. Similar work means same type of site fabrication, anchorage, setting method, and support system as the new work.

6. Materials of Construction

6.1 *Metals:*

6.1.1 Metals used for anchors or anchorage system components are selected according to their use:

6.1.1.1 Metal in contact with stone should be AISI Type 304 or 316 stainless steel, or bronze, or aluminum coated with epoxy paint or equivalent coating after fabrication. Mill finish or anodized aluminum can be used with granite. Consult metal industry

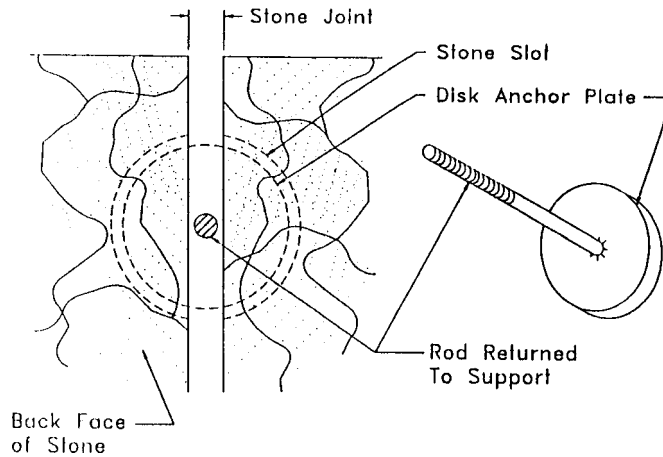

FIG. 6 Disc Anchor

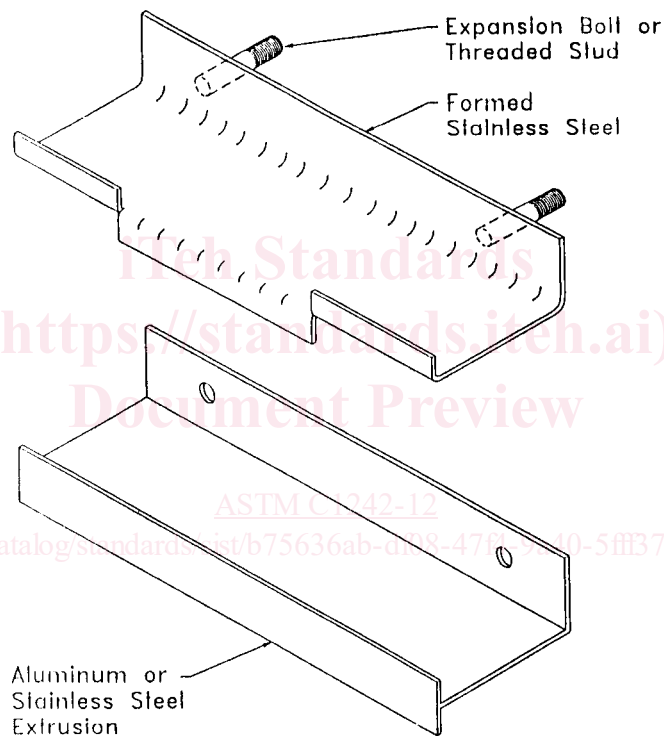

FIG. 7 Combined Anchor

references regarding specific application limitations and requirements, however, use Type 316 stainless steel when the project is exposed to chlorides, including locations exposed to deicing salt-laden road mists and locations within 5 to 10 miles of a saltwater body. Copper, brass and stainless steel wire are used for ties.

6.1.1.2 Stainless steel components less than 1/4-in. (6-mm) thick should not be welded. Where welding is required in the assembly, use low-carbon versions of the alloys such as Type 304L where Type 304 is allowed and Type 316L where Type 316 is allowed.

6.1.1.3 Exterior wire ties used with cement mortar spots should be ductile stainless steel. Avoid copper and aluminum with mortar due to incompatibility. Stainless steel, copper, brass and aluminum can be used with gypsum or molding plaster for interior applications. Verify mortar or plaster will not darken or stain stone before using wire ties with spots for anchors.

6.1.1.4 Metal not in direct contact with stone exposed to weather should be stainless steel, galvanized steel, zinc-rich painted or epoxy-coated steel, or aluminum.

6.2 Sealants:

6.2.1 Sealants used in contact with stone in joints or anchor kerfs, slots or holes should be the material recommended for the application by both the sealant manufacturer and the stone fabricator. Proper consideration should be given to the sealant's ability to satisfy the required properties of surface adhesion, tear and peel strength, elasticity, compressibility, durometer, resistance to soiling and fading, and compatibility with any other sealant with which it may contact.

6.2.1.1 The sealant manufacturer's recommendations for preparation of stone substrate, temperature range of application, and the necessity for a primer should be followed.

6.2.1.2 Some sealants contain ingredients that may penetrate or bleed into some stones over time. Before installation begins, the sealant manufacturer should test the proposed sealant on the project's stone to confirm deleterious effects, such as fluid migration, bleed into the stone, surface staining and dirt pickup, will not occur under wet and dry conditions and ultraviolet exposure.

6.2.1.3 Some sealants attract particulates that wash onto adjacent surfaces and appear to cause staining of some stones; existing installations of the proposed sealant should be evaluated for evidence of staining or accumulation of contaminants on the surface of the stone.

6.2.1.4 Substrates in contact with sealants should be cleaned, primed and prepared. Sealant profiles and joint backers should be selected and placed, and sealant material should be selected and installed in the joints in accordance with Guide C1193 and the sealant manufacturer's recommendations.

6.2.1.5 Sealant joint widths should be sized to accommodate the cross-section profile, elastic properties of the sealant material, and the anticipated movement, or range of change in width of the joint.

6.3 Mortar Materials:

6.3.1 Portland cement, masonry cement, and lime used in preparing cement and lime mortar should be non-staining.

6.3.2 Non-shrink grout should not be used.

6.4 Gaskets:

6.4.1 Gaskets used in contact with stone should be the material type recommended for the application by the gasket manufacturer and the stone fabricator. Proper consideration should be given to the gasket's ability to satisfy the required properties of tear strength, elasticity, compressibility, compression set, durometer, resistance to soiling and fading, resistance to ultraviolet, ozone and other atmospheric exposure, and compatibility with other materials with which it may contact.

6.4.1.1 Follow the gasket manufacturer's and stone fabricator's mutually-recommended preparation of stone substrate to retain the gasket's position in the joint.

6.4.1.2 Some gaskets contain ingredients that may disintegrate, or penetrate into some stones over time. Before installation begins, the gasket manufacturer should test the proposed gasket on the project's stone to confirm deleterious effects such as ozone degradation, penetration into the stone, surface staining and dirt pickup, will not occur under wet and dry conditions and ultraviolet exposure.

6.4.1.3 Gaskets can be manufactured by extruding in a variety of shapes: tubular, lobed, cellular, and dual-durometer. Extruded solid or cellular foamed gaskets are usually santoprene or silicone. Neoprene, butyl, and vinyl materials should be avoided due to their poor resistance to atmospheric exposure and potential for staining.

6.4.1.4 Gasket joint widths should be sized to accommodate the elastic properties of the gasket material and its performance in its installed cross-sectional shape. Evaluate compression required to attain the gasket's seal, grip, and to accommodate anticipated movement, or range of change in width of the joint.

7. Selection Considerations

7.1 Review the following factors before selecting a stone material, an anchoring system and subframe system from those options being considered:

7.1.1 Have the stone materials under consideration performed well on existing buildings in similar exposures?

7.1.2 Have the different anchoring and subframe systems under consideration performed well on existing buildings in similar exposures?

7.1.3 How is the performance of the anchor and its engagement into the stone affected by installation and handling procedures?

7.1.4 How are the performance and appearance of the subframe, the anchor's connection to the subframe, and the subframe's connections to the building structure affected by differential movements?

7.1.5 Do the physical characteristics of the stone measured by standard tests show the material has structural limitations? Which physical properties are important to the application, and which test methods measure those properties and their variability? Refer to Table 2 for standard test methods and properties they measure.

7.1.6 Do the physical characteristics of the stone not measured by standard tests suggest the material may have long-term durability concerns? Other properties, including (but not limited to) resistance to chemical attack, weather-related strength reduction, and dimensional changes, might be evaluated by special laboratory tests designed to obtain data under simulated conditions.

7.1.7 Does the project location or shape develop exceptional design wind, or seismic loads, or does the stone material require higher safety factors than other stones not anticipated by statutory codes?

7.1.8 Do the anchor and subframe system accommodate building dimensional changes caused by wind and seismic sway, thermal and elastic deformation, creep and shrinkage, and their combined effects?

7.1.9 Will contiguous facade elements such as windows, other claddings, window supports, or window-washing and wall maintenance provisions influence the stone cladding, its anchoring or subframe system?

7.1.10 Do the anchor or subframe systems penetrate waterproofing, facilitate internal moisture collection, or penetrate wall insulation and cavity ventilation?

7.1.11 Do the materials used resist corrosion, galvanic and chemical reactions?

7.2 The following general rules are helpful in the design of anchors and connections:

7.2.1 The simplest connections are usually the best.

7.2.2 Make connections with the fewest components.

7.2.3 Use the fewest possible anchor connection types in any particular project.

7.2.4 Provide for adjustability in connections to accommodate tolerances in materials and construction.

7.2.5 Distribute the weight of stone or panel systems on no more than two points of connection where possible.

7.2.6 Make anchor connection locations accessible to the craftsman.

7.2.7 Design connection components and stone sinkages to avoid entrapping moisture.

7.2.8 At friction connections with slotted holes parallel to the direction of load, specify proper bolts, washers, slot size, and bolt installation procedure.

7.3 *Safety Factors*—In order to design an anchoring system, the variabilities of the materials being considered should be known and compensated. This is accomplished through the use of an appropriate safety factor to be applied to the stone, the anchorage, and the backup structure.

7.3.1 Table 3 shows generally accepted Safety Factors for stone cladding by stone type. These factors are recognized by industry specialists and publications and are based upon past successful practice. These factors are based on a maximum coefficient of variation of 20 % when project samples are tested in accordance with Test Methods C99 or C880 for sedimentary stones in thicknesses of 2 in. (50 mm) or greater. Safety factors could be changed when conditions listed under 7.3.2 or 7.3.3 exist in the project.

7.3.2 *Exemplar Availability*:

A safety factor could be modified if the long-term performance of the stone material, anchor and backup system cannot be verified by well-performing exemplars. Consult a stone specialist as defined in 4.4 for the appropriate change in safety factor.

7.3.3 *Structural Variables*:

A safety factor could be modified if specific conditions exist on the project different from those upon which Table 3 values are based. Consult a stone specialist as defined in 4.4 for the appropriate change in safety factor. Some specific conditions are:

7.3.3.1 Critical material strength tests show increased variability;

7.3.3.2 Life expectancy of project exceeds forty years;

7.3.3.3 Stone material loses significant strength over time;

7.3.3.4 When designing stone at anchors;

7.3.3.5 Anchor capacity tests show increased variability;

7.3.3.6 Anchors will not be inspected in final position on building;

7.3.3.7 Anchors require varied installation techniques or varied positions;

7.3.3.8 Panel is used in higher-risk position such as a soffit, overhang, liner block, assembled on backup before being erected or other similar position.

8. Design Process

8.1 *System Parts*—There are five main interrelated parts in a stone facade system that are to be considered when designing the cladding system:

8.1.1 *Stone Panels*, cladding the facade,

8.1.2 *Joints*, between the panels,

8.1.3 *Anchor*, connecting the cladding to the supporting backup,

8.1.4 *Subframes*, connecting the anchors to the building structure where the anchor does not attach directly to the building, and

8.1.5 *Primary Building Structure*.

8.2 *Process Purpose*—In this section a recommended process is provided to help designers select and design anchors that provide a reliable and durable overall cladding system. The process begins with preliminary design by evaluating exemplars, then confirms the system's fitness with engineering by structural analysis and appropriate physical tests. Engineering first evaluates individual parts of the system, then evaluates key assemblies of parts, then evaluates the fully built system.

8.3 *Process Scope*—This section outlines primary elements that should be considered in the design process. Extent of exemplar assessments, analyses and tests needed to formulate a well-performing preliminary design and establish its reliability and durability

TABLE 3 Generally Accepted Safety Factors for Stone Cladding by Stone Type

Stone Type	Specification	Safety Factor
granite	C615	3
limestone	C568	6
group A marble	C503	5
travertine	C1527	8
sandstone	C616	6
slate	C629	5

varies with the type of project, its size, location, and applicability of exemplars. Consider employing a specialist experienced with stone materials, anchors, backup and building structure to develop an assessment, analysis and testing program appropriate for the project if additional expertise is needed. All listed elements are not required for all projects. Some projects may require elements not listed.

8.3.1 Proposed cladding systems which have stone materials in thickness modules, panel sizes, anchors, and backups very similar to well-performing exemplars in the same climate may, at the architect's option, be exempted from some or all of the testing program if analysis assures the system is reliable and durable.

8.3.2 Proposed cladding systems that do not have sufficiently-old well-performing exemplars sharing similar stone materials in thickness modules, panel sizes, anchors and backups and in the same climate probably require testing and analysis during preliminary design. At the architect's option, systems without exemplars require an extensive testing program and analysis to attempt to predict system reliability and durability in the proposed application and its climate.

8.3.3 Projects to be built very similar to well-performing exemplars require less rigorous analysis and testing.

8.3.4 Projects to be built of less-commonly-used materials or common materials in unconventional systems lacking precedents of well-performing exemplars require more rigorous analysis and testing.

8.3.5 Assess exemplars to develop cladding system concept and complete preliminary engineering and testing before determining if the desired stone or the proposed cladding backup is appropriate. Do not choose a stone material for its appearance without verifying it is appropriate for the project climate. Also, do not choose a backup system without matching it to the project climate, stone anchor requirements and architectural arrangement of cladding.

8.4 Terminology:

8.4.1 *exemplar, adj*—a constructed example sharing some similar parts, assemblies, arrangements or exposures with the proposed system.

8.4.1.1 *well-performing, adj*—the example is serviceable its entire expected life. Serviceable stone cladding systems maintain their original integrity without more than routine upkeep. How long an example should be serviceable will vary by building type, owner, user, builder or designer, but the longer it remains serviceable, the more reliable and durable it is. A well-performing exemplar is only as reliable and durable to the extent its cladding system performs as expected over time.

8.4.1.2 *poor-performing, adj*—stone-cladding system integrity declines unexpectedly before it should. While observable deficiencies may show some parts of an example to be poor-performing, absence of seen problems without confirming performance by inspecting concealed conditions or testing does not necessarily make it a well-performing example.

8.4.2 *durable, adj*—the building system performs reliably during its entire service life and will endure environmental exposure and changes in adjacent elements without diminished serviceability. Make the design durable by assessing exemplars and including their well-performing elements while avoiding their poorly-performing elements.

8.4.3 *reliable, adj*—the building system performs while remaining in a safe state under load cases outlined by code or greater loads if required by the project. Establish reliability using an engineering evaluation that shows how well loads on cladding are carried through the panel, anchors and backup support system to the building structure.

8.5 *Preliminary Design*—Assess exemplars to extract concepts critical to developing preliminary designs with high reliability and durability. Assess both well-performing and poor-performing exemplars. The highest reliability and durability can be attained when the preliminary design includes elements of well-performing exemplars and excludes elements of poor-performing exemplars. General exemplar assessment should include the following:

8.5.1 Buildings using the same stone material being considered in the architectural concept, in an environment similar to the new project's location.

8.5.1.1 Check stone panel sizes, thickness, support points where possible. Research whether current quarry operations yield similar product and if tests of recently fabricated material are consistent with past production ten, twenty or fifty years ago. This check will help keep the architectural concept compatible with the structural properties of available stone materials and suggest the extent of new testing necessary.

8.5.1.2 Determine the realistic fabrication limitations of the stone by examining joint widths, piece sizes, piece shape, material quantity, visual range and consistency of color, veining, and markings, type of finish, cleanliness in its location of use on the building. Research by visiting the quarry, or fabricator, or both, when possible or practical whether current fabrication capabilities and currently quarried deposits represent stone material observed an exemplar.

8.5.1.3 Learn properties of currently produced stone by visiting the quarry, or fabricator, or both, when possible or practical, and by obtaining previous test reports or a written statement from the producer to compare it to stone material observed on exemplar.

8.5.2 Buildings supporting cladding with similar anchors or backup being considered for the new project, independent of stone type. Obtaining this information likely requires contacting potential anchor manufacturers and stone installers to locate exemplars and once exemplars are identified, perhaps contacting their structural engineer or architect. An experienced cladding specialist could help decipher this information without excavating the wall. Marrying the appropriate support with the desired material is as critical to attaining a durable project as choosing the appropriate stone type.

8.5.2.1 Inspect the facade surface as closely as possible for symptoms of internal distress such as staining, cracks, spalls, open joints, shifted panels. Using binoculars and hands-on where possible, check arrises, sills, copings, building corners, plane changes,