



Designation: ~~D4239-11~~ Designation: D4239 – 12

Standard Test Method for Sulfur in the Analysis Sample of Coal and Coke Using High- Temperature Tube Furnace Combustion¹

This standard is issued under the fixed designation D4239; the number immediately following the designation indicates the year of original adoption or, in the case of revision, the year of last revision. A number in parentheses indicates the year of last reapproval. A superscript epsilon (ϵ) indicates an editorial change since the last revision or reapproval.

This standard has been approved for use by agencies of the Department of Defense.

1. Scope

1.1 This test method covers the determination of sulfur in samples of coal or coke by high-temperature tube furnace combustion.

~~1.2 When automated equipment is used the procedure can be classified as an instrumental method.~~

~~1.1.1 Two analysis methods are described.~~

~~1.2 When automated equipment is used, either method can be classified as an instrumental method.~~

1.3 The values stated in SI units are to be regarded as standard. No other units of measurement are included in this standard.

1.4 *This standard does not purport to address all of the safety concerns, if any, associated with its use. It is the responsibility of the user of this standard to establish appropriate safety and health practices and determine the applicability of regulatory limitations prior to use.*

2. Referenced Documents

2.1 *ASTM Standards:*²

D346 [Practice for Collection and Preparation of Coke Samples for Laboratory Analysis](#)

D2013 [Practice for Preparing Coal Samples for Analysis](#)

D3173 [Test Method for Moisture in the Analysis Sample of Coal and Coke](#)

D3176 [Practice for Ultimate Analysis of Coal and Coke](#)

D3180 [Practice for Calculating Coal and Coke Analyses from As-Determined to Different Bases](#)

D7448 [Practice for Establishing the Competence of Laboratories Using ASTM Procedures in the Sampling and Analysis of Coal and Coke](#)

D7582 [Test Methods for Proximate Analysis of Coal and Coke by Macro Thermogravimetric Analysis](#)

E691 [Practice for Conducting an Interlaboratory Study to Determine the Precision of a Test Method](#)

2.2 *ISO Standard:*³

ISO 11722 [Solid Mineral Fuels-Hard Coal – Determination of Moisture in the general analysis test sample by drying in nitrogen](#)

3. Summary of Test Method

3.1 *Combustion Method with Infrared Absorption Detection A (1350°C)*—A weighed test portion of sample is burned in a tube furnace at a minimum combustion tube operating temperature of 1350°C in a stream of oxygen. During combustion at temperatures above 1350 °C, the sulfur and sulfur compounds contained in the sample are decomposed and oxidized almost exclusively to gaseous sulfur dioxide, SO₂. Moisture and particulates are removed from the gas by filters. The gas stream is passed through a cell in which sulfur dioxide is measured by an infrared (IR) absorption detector. Sulfur dioxide absorbs IR energy at a precise wavelength within the IR spectrum. Energy is absorbed as the gas passes through the cell body in which the IR energy is being transmitted: thus, at the detector, less energy is received. All other IR energy is eliminated from reaching the detector by a precise wavelength filter. Thus, the absorption of IR energy can be attributed only to sulfur dioxide whose concentration is proportional to the change in energy at the detector. One cell is used as both a reference and a measurement chamber. Total sulfur as sulfur dioxide is detected on a continuous basis.

¹ This test method is under the jurisdiction of ASTM Committee D05 on Coal and Coke and is the direct responsibility of Subcommittee D05.21 on Methods of Analysis. Current edition approved April 1, 2011. Published April 2011. Originally approved in 1983. Last previous edition approved in 2010 as D4239-10^{ε1}. DOI: 10.1520/D4239-11.

Current edition approved Feb. 1, 2012. Published February 2012. Originally approved in 1983. Last previous edition approved in 2011 as D4239-11. DOI: 10.1520/D4239-12.

² For referenced ASTM standards, visit the ASTM website, www.astm.org, or contact ASTM Customer Service at service@astm.org. For *Annual Book of ASTM Standards* volume information, refer to the standard's Document Summary page on the ASTM website.

³ Available from International Organization for Standardization (ISO), 1, ch. de la Voie-Creuse, Case postale 56, CH-1211, Geneva 20, Switzerland, http://www.iso.ch.

3.2 *Combustion Method B (1150°C)*—A weighed test portion of sample is burned in a quartz combustion tube in a stream of oxygen with an equal or excess weight of tungsten trioxide (WO_3). Sulfur is oxidized during the reaction of the sample and WO_3 . The tube furnace is operated at a minimum combustion tube operating temperature of 1150°C and tin (Sn) sample boats are utilized. Moisture and particulates are removed from the combustion gas by filters. The gas stream is then passed through a cell in which sulfur dioxide is measured by an infrared (IR) absorption detector. Sulfur dioxide absorbs IR energy at a precise wavelength within the IR spectrum. Energy is absorbed as the gas passes through the cell body in which the IR energy is being transmitted: thus, at the detector, less energy is received. All other IR energy is eliminated from reaching the detector by a precise wavelength filter. Thus, the absorption of IR energy can be attributed only to sulfur dioxide whose concentration is proportional to the change in energy at the detector. One cell is used as both a reference and a measurement chamber. Total sulfur as sulfur dioxide is detected on a continuous basis.

4. Significance and Use

4.1 Sulfur is part of the ultimate analysis of coal and coke.

4.2 Results of the sulfur analysis are used for evaluation of coal preparation and cleaning, evaluation of potential sulfur emissions from coal and coke combustion or conversion processes, and evaluation of coal and coke quality in relation to contract specifications, as well as for scientific purposes.

4.3 The competency of laboratories with respect to use of this standard can be established through reference to Practice D7448.

5. Sample

5.1 Pulverize the sample to pass No. 60 (250- μ m) sieve and mix thoroughly in accordance with Practice D2013 or Practice D346.

5.2 Analyze a separate portion of the analysis sample for moisture content in accordance with Test Method D3173, or D7582 or ISO 11722 for calculations to other than the as-determined basis.

5.3 Procedures for calculating as-determined sulfur values obtained from the analysis sample to other bases are described in Practices D3176 and D3180.

6. Apparatus

Combustion Method A (1350°C)

6.1 *Measurement Apparatus*—Equipped to combust the sample as described in 3.1 (See Fig. 1).

6.2 *Tube Furnace*—Capable of heating the hot zone of the combustion tube (—Capable of heating the hot zone or outer surface of the combustion tube, or both (6.3) to at least 1350°C. It is normally heated electrically using resistance rods, a resistance wire, or molybdenum disilicide elements. Specific dimensions can vary with manufacturer's design.

6.3 *Combustion Tube*—Made of mullite, porcelain, or zircon with provisions for routing the gasses produced by combustion through the infrared cell. —Made of mullite, porcelain, or zircon with provisions for routing the gasses produced by combustion

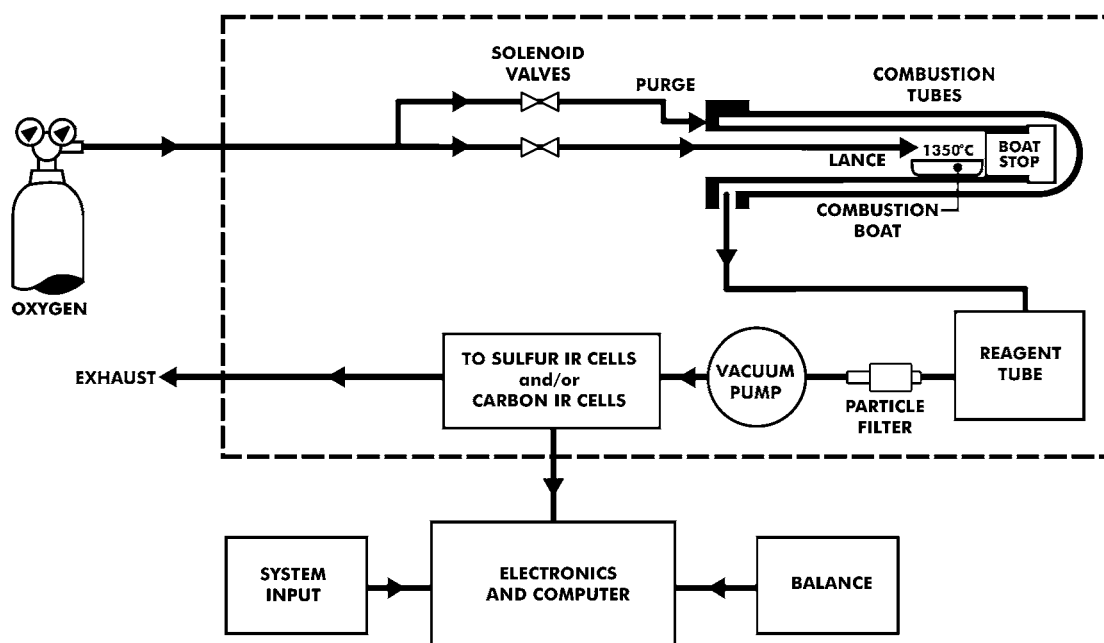

FIG. 1 Apparatus for the Determination of Sulfur by the Infrared Detection, Method A

through the infrared cell. The tube may have a boat stop made of reticulated ceramics heated to 1350°C that serves to complete the combustion of sulfur containing materials.

6.4 *Sample Combustion Boats*, made of iron-free material and of a convenient size suitable for the dimensions of the combustion tube.

6.5 *Boat Puller*—Where required, a rod of a heat-resistant material with a bent or disk end to insert and remove boats from the combustion tube.

Combustion Method B (1150°C)

6.6 *Measurement Apparatus*—Equipped to combust the sample as described in 3.2 (See Fig. 2)

6.7 *Tube Furnace*—Capable of heating the hot zone or outer surface of the combustion tube, or both (6.8) to at least 1150°C. It is normally heated electrically using resistance wire. Specific dimensions can vary with manufacturer’s design.

6.8 *Combustion Tube*—Made of quartz with provisions for routing the gases produced by combustion through the infrared cell.

6.9 *Sample Combustion Boat*—Made of an iron-free tin material and of a convenient size suitable for the dimensions of the combustion tube.

7. Reagents

7.1 *Purity of Reagents*—Use reagent grade chemicals in all tests. Unless otherwise indicated, it is intended that all reagents conform to the specifications of the Committee on Available Reagents of the American Chemical Society, where such specifications are available.⁴ Other grades can be used, provided it is first ascertained the reagent is of sufficiently high purity to permit its use without lessening the accuracy of the determination.

7.2 *Magnesium Perchlorate*—~~(Warning—Magnesium perchlorate is a strong oxidizing agent. Do not regenerate the absorbent. Do not allow contact with organic materials or reducing agents.)~~

7.3 *Oxygen, 99.5 % Pure*—Compressed gas contained in a cylinder equipped with a suitable pressure regulator and a needle valve to control gas flow. (**Warning**—Pure oxygen vigorously accelerates combustion. Verify all regulators, lines, and valves are free of grease and oil.)

7.4 *Reference Materials, Reference Material (RM)*—that are coal(s) or coke(s) prepared by a national metrology body. Other materials that are coal(s) or coke(s) with documented traceability to reference material (CRM) coal(s) or coke(s) prepared by a national metrology body can also be used. Only use material(s) with an assigned value and assigned uncertainty for sulfur. The uncertainty expressed as the confidence interval of the assigned value shall be less than the repeatability specified in the appropriate section on Precision and Bias of this test method.

7.4.1 To minimize problems with instrument calibration or calibration verification mix all reference material before removing the test portion from the container. Do not use the reference material for calibration or calibration verification when less than 2 g remain in the container. The remaining material can be used for instrument conditioning.

7.5 *Tungsten Oxide (WO₃)*—A combustion promoter and a fluxing agent. (**Warning**—Tungsten Oxide is a strong oxidizing agent.)

<https://standards.iteh.ai/catalog/standards/sist/40c6de62-2ca1-41e9-9328-1c11703f4a24/astm-d4239-12>

8. Procedure

8.1 *Instrument Preparation*—Perform apparatus set up system checks in accordance with manufacturer’s instructions.

8.1.1 *Balance Calibration*—Calibrate the instrument balance in accordance with manufacturer’s instructions.

8.2 *Calibration of the Infrared Detection System*—~~CH₄~~—If the instrument has been previously calibrated in accordance with the section on instrument calibration proceed to the Analysis Procedure, otherwise carry out a calibration as specified in the section on instrument calibration.

⁴ *Reagent Chemicals, American Chemical Society Specifications*, American Chemical Society, Washington, DC. For suggestions on the testing of reagents not listed by the American Chemical Society, see *Analar Standards for Laboratory Chemicals*, BDH Ltd., Poole, Dorset, U.K., and the *United States Pharmacopeia and National Formulary*, U.S. Pharmacopeial Convention, Inc. (USPC), Rockville, MD.

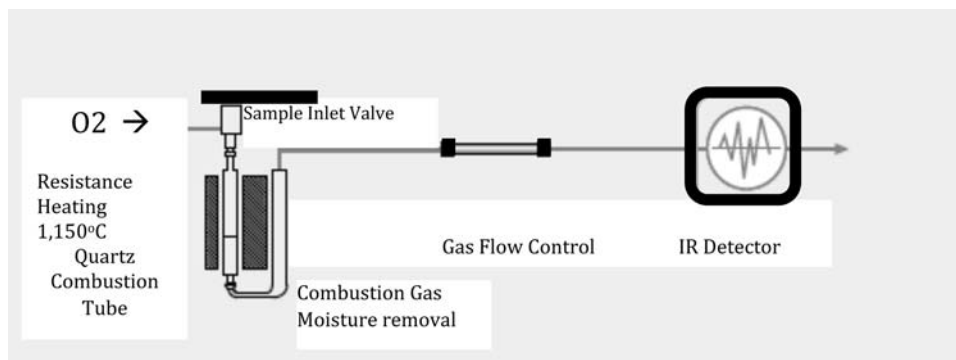

FIG. 2 Apparatus for the Determination of Sulfur by the Infrared Detection, Method B