



Designation: ~~D5778-07~~ Designation: D5778 - 12

Standard Test Method for Electronic Friction Cone and Piezocone Penetration Testing of Soils¹

This standard is issued under the fixed designation D5778; the number immediately following the designation indicates the year of original adoption or, in the case of revision, the year of last revision. A number in parentheses indicates the year of last reapproval. A superscript epsilon (ϵ) indicates an editorial change since the last revision or reapproval.

1. Scope*

1.1 This test method covers the procedure for determining the point resistance during penetration of a conical-shaped penetrometer as it is advanced into subsurface soils at a steady rate.

1.2 This test method is also used to determine the frictional resistance of a cylindrical sleeve located behind the conical point as it is advanced through subsurface soils at a steady rate.

1.3 This test method applies to friction-cone penetrometers of the electric and electronic type. Field tests using mechanical-type penetrometers are covered elsewhere by Test Method D3441.

1.4 This test method can be used to determine porewater pressures developed during the penetration, thus termed piezocone. Porewater pressure dissipation, after a push, can also be monitored for correlation to time rate of consolidation and permeability.

1.5 Additional sensors, such as inclinometer, seismic geophones (Test Methods D7400), resistivity, electrical conductivity, dielectric, and temperature sensors, may be included in the penetrometer to provide useful information. The use of an inclinometer is highly recommended since it will provide information on potentially damaging situations during the sounding process.

1.6 Cone penetration test data can be used to interpret subsurface stratigraphy, and through use of site specific correlations, they can provide data on engineering properties of soils intended for use in design and construction of earthworks and foundations for structures.

1.7 The values stated in SI units are to be regarded as standard. Within Section 13 on Calculations, SI units are considered the standard. Other commonly used units such as the inch-pound system are shown in brackets. The various data reported should be displayed in mutually compatible units as agreed to by the client or user. Cone tip projected area is commonly referred to in square centimetres for convenience. The values stated in each system are not equivalents; therefore, each system must shall be used independently of the other.

NOTE 1—This test method does not include hydraulic or pneumatic penetrometers. However, many of the procedural requirements herein could apply to those penetrometers. Also, offshore/marine CPT systems may have procedural differences because of the difficulties of testing in those environments (for example, tidal variations, salt water, waves). Mechanical CPT systems are covered under Test Method D3441.

1.8 *This standard does not purport to address all of the safety concerns, if any, associated with its use. It is the responsibility of the user of this standard to establish appropriate safety and health practices and determine the applicability of regulatory limitations prior to use.*

2. Referenced Documents

2.1 *ASTM Standards:*²

D653 [Terminology Relating to Soil, Rock, and Contained Fluids](#)

D3441 [Test Method for Mechanical Cone Penetration Tests of Soil](#)

D3740 [Practice for Minimum Requirements for Agencies Engaged in Testing and/or Inspection of Soil and Rock as Used in Engineering Design and Construction](#)

D7400 [Test Methods for Downhole Seismic Testing](#)

E4 [Practices for Force Verification of Testing Machines](#)

¹ This test method is under the jurisdiction of ASTM Committee D18 on Soil and Rock and is the direct responsibility of Subcommittee D18.02 on Sampling and Related Field Testing for Soil Evaluations.

Current edition approved Nov. 1, 2007. Published December 2007. Originally approved in 1995. Last previous edition approved in 2000 as D5778-95 (2000). DOI: 10.1520/D5778-07.

Current edition approved Jan. 1, 2012. Published February 2012. Originally approved in 1995. Last previous edition approved in 2007 as D5778-07. DOI: 10.1520/D5778-12.

² For referenced ASTM standards, visit the ASTM website, www.astm.org, or contact ASTM Customer Service at service@astm.org. For *Annual Book of ASTM Standards* volume information, refer to the standard's Document Summary page on the ASTM website.

*A Summary of Changes section appears at the end of this standard.

3. Terminology

3.1 Definitions:

3.1.1 Definitions are in accordance with Terminology Convention (D653).

3.2 Definitions of Terms Specific to This Standard:

3.2.1 *apparent load transfer*—apparent resistance measured on either the cone or friction sleeve of an electronic cone penetrometer while that element is in a no-load condition but the other element is loaded. Apparent load transfer is the sum of cross talk, subtraction error, and mechanical load transfer.

3.2.2 *baseline*—a set of zero load readings, expressed in terms of apparent resistance, that are used as reference values during performance of testing and calibration.

3.2.3 *cone tip*—the conical point of a cone penetrometer on which the end bearing component of penetration resistance is developed. The cone has a 60° apex angle, a diameter of 35.7 mm, and a corresponding projected (horizontal plane) surface area or cone base area of 10 cm². Also, enlarged cones of 43.7 mm diameter (base area = 15 cm²) are utilized.

3.2.4 *cone penetration test*—a series of penetration readings performed at one location over the entire vertical depth when using a cone penetrometer. Also referred to as a cone sounding.

3.2.5 *cone penetrometer*—a penetrometer in which the leading end of the penetrometer tip is a conical point designed for penetrating soil and for measuring the end-bearing component of penetration resistance.

3.2.6 *cone resistance, q_c* —the measured end-bearing component of penetration resistance. The resistance to penetration developed on the cone is equal to the vertical force applied to the cone divided by the cone base area.

3.2.7 *corrected total cone resistance, q_t* —tip resistance corrected for water pressure acting behind the tip (see 13.2.1). Correction for water pressure requires measuring water pressures with a piezocone element positioned behind the tip at location u_2 (See section 3.2.26). The correction results in estimated total tip resistance, q_t .

3.2.8 *cross talk*—an apparent load transfer between the cone and the friction sleeve caused by interference between the separate signal channels.

3.2.9 *electronic cone penetrometer*—a friction cone penetrometer that uses force transducers, such as strain gauge load cells, built into a non-telescoping penetrometer tip for measuring, within the penetrometer tip, the components of penetration resistance.

3.2.10 *electronic piezocone penetrometer*—~~an electronic cone penetrometer equipped with a low volume fluid chamber, porous element, and pressure transducer for determination of porewater pressure at the porous element soil interface.~~ —an electronic cone penetrometer equipped with a low volume fluid chamber, porous element, and pressure transducer for determination of porewater pressure at the porous element soil interface measured simultaneously with end bearing and frictional components of penetration resistance.

3.2.11 *end bearing resistance*—same as cone resistance or tip resistance, q_c .

3.2.12 *equilibrium pore water pressure, u_0* —~~at rest water pressure at depth of interest. Same as hydrostatic pressure (see Terminology D653).~~ —at rest water pressure at depth of interest.

3.2.13 *excess pore water pressure, Δu* —the difference between porewater pressure measured as the penetration occurs (u), and estimated equilibrium porewater pressure (u_0), or: $\Delta u = (u - u_0)$. Excess porewater pressure can either be positive or negative for shoulder position filters.

3.2.14 *friction cone penetrometer*—a cone penetrometer with the capability of measuring the friction component of penetration resistance.

3.2.15 *friction ratio, R_f* —~~the ratio of friction sleeve resistance, f_s , to cone resistance, q_c , measured at where the middle of the friction sleeve and cone point are at the same depth, expressed as a percentage.~~ , measured at where the middle of the friction sleeve and cone point are at the same depth, expressed as a percentage.

NOTE 2—Some methods to interpret CPT data use friction ratio defined as the ratio of sleeve friction, f_s , to cone resistance corrected for pore pressure effects q_t , (4). It is not within the scope of this standard to recommend which methods of interpretation are to be used.

3.2.16 *friction reducer*—a narrow local protuberance on the outside of the push rod surface, placed at a certain distance above the penetrometer tip, that is provided to reduce the total side friction on the push rods and allow for greater penetration depths for a given push capacity.

3.2.17 *friction sleeve*—an isolated cylindrical sleeve section on a penetrometer tip upon which the friction component of penetration resistance develops. The friction sleeve has a surface area of 150 cm² for 10-cm² cone tips or 225 cm² for 15-cm² tips.

3.2.18 *friction sleeve resistance, f_s* —the friction component of penetration resistance developed on a friction sleeve, equal to the shear force applied to the friction sleeve divided by its surface area.

3.2.19 *FSO*—abbreviation for full-scale output. The output of an electronic force transducer when loaded to 100 % rated capacity.

3.2.20 *local side friction*—same as friction sleeve resistance, f_s (see 3.2.18).

3.2.21 *penetration resistance measuring system*—a measuring system that provides the means for transmitting information from the penetrometer tip and displaying the data at the surface where it can be seen or recorded.

3.2.22 *penetrometer*—an apparatus consisting of a series of cylindrical push rods with a terminal body (end section), called the penetrometer tip, and measuring devices for determination of the components of penetration resistance.

3.2.23 *penetrometer tip*—the terminal body (end section) of the penetrometer which contains the active elements that sense the

components of penetration resistance. The penetrometer tip may include additional electronic instrumentation for signal conditioning and amplification.

3.2.24 *piezocone*—same as *electronic piezocone penetrometer* (see 3.2.10).

3.2.25 *piezocone porewater pressure, u*—fluid pressure measured using the piezocone penetration test.

3.2.26 *piezocone porewater pressure measurement location: u_1, u_2, u_3* —fluid pressure measured by the piezocone penetrometer at specific locations on the penetrometer as follows **(1, 2, 3)**³: u_1 —porous filter location on the midface or tip of the cone, u_2 —porous filter location at the shoulder position behind the cone tip (standard location) and, u_3 —porous filter location behind the friction sleeve.

3.2.27 *porewater pressure*—total porewater pressure magnitude measured during penetration (same as 3.2.25 above).

3.2.28 *porewater pressure ratio parameter, B_q* —the ratio of excess porewater pressure at the standard measurement location Δu_2 , to corrected total cone resistance q_r , minus the total vertical overburden stress, σ_{vo} (see Eq 10).

3.2.29 *push rods*—the thick-walled tubes or rods used to advance the penetrometer tip.

3.2.30 *sleeve friction, sleeve, and friction resistance*—same as friction sleeve resistance.

3.2.31 *subtraction error*—an apparent load transfer from the cone to the friction sleeve of a subtraction type electronic cone penetrometer caused by minor voltage differences in response to load between the two strain element cells.

3.3 *Abbreviations:*

3.3.1 *CPT*—abbreviation for the cone penetration test.

3.3.2 *PCPT or CPTu* **PCPT (1, 2) or CPTu (3)**—abbreviation for piezocone penetration test (note: symbol “u” added for porewater pressure measurements).

3.3.3 *CPT \dot{u}* —abbreviation for the piezocone penetration test with dissipation phases of porewater pressures (\dot{u}).

3.3.4 *SCPTu*—abbreviation for seismic piezocone test Test Methods D7400 (includes one or more geophones to allow downhole geophysical wave velocity measurements).

3.3.5 *RCPTu*—abbreviation for resistivity piezocone (includes electrical conductivity or resistivity module).

4. Summary of Test Method

4.1 A penetrometer tip with a conical point having a 60° apex angle and a cone base area of 10 or 15 cm² is advanced through the soil at a constant rate of 20 mm/s. The force on the conical point (cone) required to penetrate the soil is measured by electrical methods, at a minimum of every 50 mm of penetration. Improved resolution may often be obtained at 20- or 10-mm interval readings. Stress is calculated by dividing the measured force (total cone force) by the cone base area to obtain cone resistance, q_c .

4.2 A friction sleeve is present on the penetrometer immediately behind the cone tip, and the force exerted on the friction sleeve is measured by electrical methods at a minimum of every 50 mm of penetration. Stress is calculated by dividing the measured axial force by the surface area of the friction sleeve to determine sleeve resistance, f_s .

4.3 Most modern penetrometers are capable of registering pore water pressure induced during advancement of the penetrometer tip using an electronic pressure transducer. These penetrometers are called “piezocones.” The piezocone is advanced at a rate of 20 mm/s, and readings are taken at a minimum of every 50 mm of penetration. The dissipation of either positive or negative excess porewater pressure can be monitored by stopping penetration, unloading the push rod, and recording porewater pressure as a function of time. When porewater pressure becomes constant it is measuring the equilibrium value (designated u_0) or piezometric level at that depth.

5. Significance and Use

5.1 Tests performed using this test method provide a detailed record of cone resistance which is useful for evaluation of site stratigraphy, homogeneity and depth to firm layers, voids or cavities, and other discontinuities. The use of a friction sleeve and porewater pressure element can provide an estimate of soil classification, and correlations with engineering properties of soils. When properly performed at suitable sites, the test provides a rapid means for determining subsurface conditions.

5.2 This test method provides data used for estimating engineering properties of soil intended to help with the design and construction of earthworks, the foundations for structures, and the behavior of soils under static and dynamic loads.

~~5.3 This method tests the soil in-situ and soil samples are not obtained. The interpretation of the results from this test method provides estimates of the types of soil penetrated. Engineers may obtain soil samples from parallel borings for correlation purposes but prior information or experience may preclude the need for borings.~~

5.3 This method tests the soil in-situ and soil samples are not obtained. The interpretation of the results from this test method provides estimates of the types of soil penetrated. Engineers may obtain soil samples from parallel borings for correlation purposes but prior information or experience may preclude the need for borings.

NOTE 3—The quality of the results produced by this standard is dependent on the competence of the personal performing the test, and the suitability of the equipment and facilities used. Agencies that meet the criteria of Practice D3740 are generally considered capable of competent and objective testing/sampling/inspection/etc. Users of this standard are cautioned that compliance with Practice D3740 does not in itself assure reliable results. Reliable results depend on many factors and Practice D3740 provides a means of evaluating some of those factors.

6. Interferences

6.1 Refusal, deflection, or damage to the penetrometer may occur in coarse grained soil deposits with maximum particle sizes

³ The boldface numbers given in parentheses refer to a list of references at the end of the text.

that approach or exceed the diameter of the cone.

6.2 Partially lithified and lithified deposits may cause refusal, deflection, or damage to the penetrometer.

6.3 Standard push rods can be damaged or broken under extreme loadings. The amount of force that push rods are able to sustain is a function of the unrestrained length of the rods and the weak links in the push rod-penetrometer tip string such as push rod joints and push rod-penetrometer tip connections. The force at which rods may break is a function of the equipment configuration and ground conditions during penetration. Excessive rod deflection is the most common cause for rod breakage.

7. Apparatus

7.1 *Friction Cone Penetrometer*—The penetrometer tip should meet requirements as given below and in 10.1. In a conventional friction-type cone penetrometer, the forces at the cone tip and friction sleeve are measured by two load cells within the penetrometer. Either independent load cells or subtraction-type penetrometers are acceptable for use (Fig. 1).

7.1.1 In the subtraction-type penetrometer, the cone and sleeve both produce compressive forces on the load cells. The load cells are joined together in such a manner that the cell nearest the cone (the “C” cell in Fig. 1*b*) measures the compressive force on the cone while the second cell (the “C + S” cell in Fig. 1*b*) measures the sum of the compressive forces on both the cone and friction sleeve. The compressive force from the friction sleeve portion is computed then by subtraction. This cone design is common in industry because of its rugged design. This design forms the basis for minimum performance requirements for electronic penetrometers.

7.1.1.1 Alternative designs have separate and non-dependent load cells separate for tip and sleeve. For instance, in Fig. 1*a*, the cone penetrometer tip produces a compression force on the cone load cell (the “C” cell in Fig. 1*a*) while the friction sleeve produces a tensile force on the independent friction sleeve load cell (the “S” cell). Designs are also available where both the tip and sleeve load cells are independent and operate in compression (24). These penetrometer designs result in a higher degree of accuracy in friction sleeve measurement, however, may be more susceptible to damage under extreme loading conditions.

7.1.1.2 Typical general purpose cone penetrometers are manufactured to full scale outputs (FSO) equivalent to net loads of 10 to 20 tons. Often, weak soils are the most critical in an investigation program, and in some cases, very accurate friction sleeve data may be required. To gain better resolution, the FSO can be lowered or the independent type penetrometer design can be selected. A low FSO subtraction cone may provide more accurate data than a standard FSO independent type cone depending on such factors as system design and thermal compensation. If the FSO is lowered, this may place electrical components at risk if overloaded in stronger soils. Expensive preboring efforts may be required to avoid damage in these cases. The selection of penetrometer type and resolution should consider such factors as practicality, availability, calibration requirements, cost, risk of damage, and preboring requirements.

7.1.1.3 The user or client should select the cone design requirements by consulting with experienced users or manufacturers. The need for a specific cone design depends on the design data requirements outlined in the exploration program.

7.1.1.4 Regardless of penetrometer type, the friction sleeve load cell system must operate in such a way that the system is sensitive to only shear stresses applied to the friction sleeve and not to normal stresses.

7.1.2 *Cone*—Nominal dimensions, with manufacturing and operating tolerances, for the cone are shown on Fig. 2. The cone has a diameter $d = 35.7 \text{ mm}$, projected base area $A_c = 1000 \text{ mm}^2$, + 2 %–5 % with an apex angle of 60° . A cylindrical extension, h_e ,

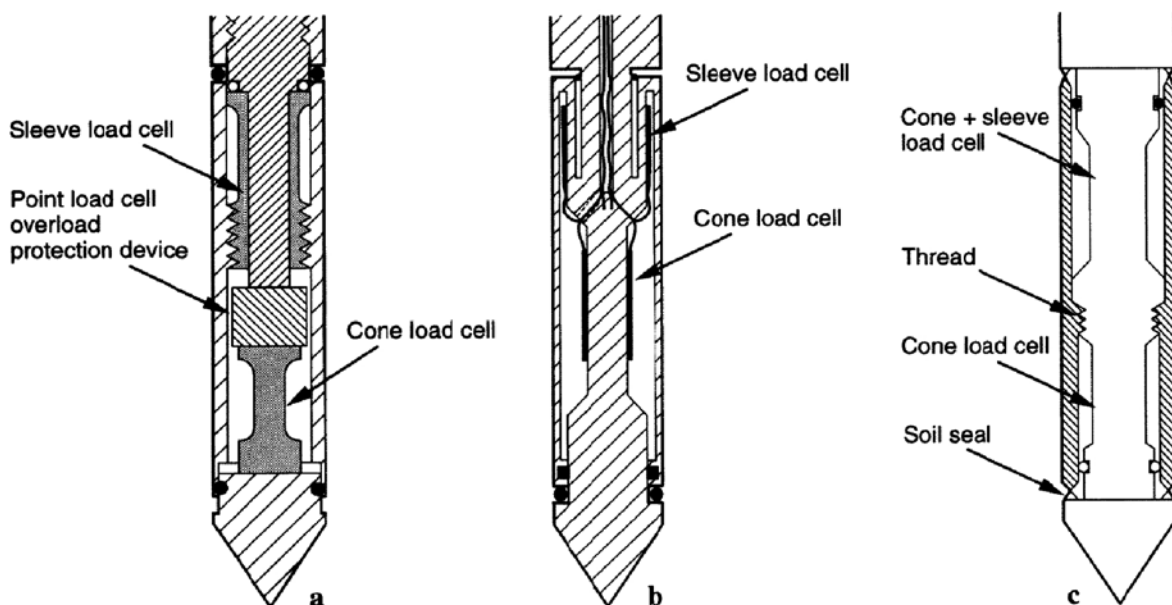

FIG. 1 Common Configurations for Electric Friction-Cone Penetrometers (24) Showing: (a) Compression-type Tip and Sleeve Load Cells, (b) Tension-type Sleeve Design, and (c) Subtraction-type Penetrometer

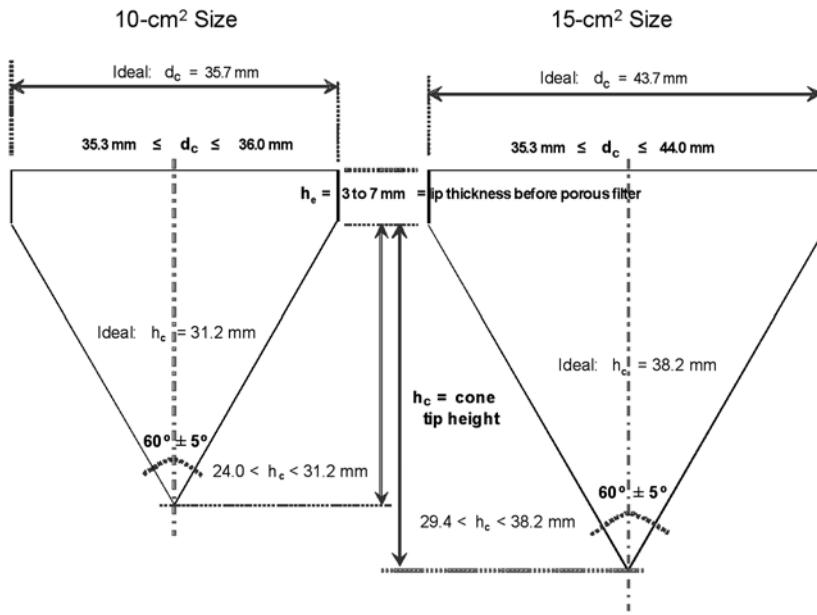

FIG. 2 Manufacturing and Operating Tolerances of Cones (35)

of 5 mm should be located behind the base of the cone to protect the outer edges of the cone base from excessive wear. The 10 cm² cone is considered the reference standard for which results of other penetrometers with proportionally scaled dimensions can be compared.

7.1.2.1 In certain cases, it may be desirable to increase the cone diameter in order to add room for sensors or increase ruggedness of the penetrometer. The standard increase is to a base diameter of 43.7 mm which provides a projected cone base area of 1500 mm² while maintaining a 60° apex angle. Nominal dimensions, with manufacturing and operating tolerances for the 15 cm² cone, are shown in Fig. 2, based on the international guides (35).

7.1.2.2 The cone is made of high strength steel of a type and hardness suitable to resist wear due to abrasion by soil. Cone tips which have worn to the operating tolerance shown in Fig. 2 should be replaced. Piezocone tips should be replaced when the tip has worn appreciably (as shown) and the height of the cylindrical extension has reduced considerably (as shown).

NOTE 2—In 4—In some applications it may be desirable to scale the cone diameter down to a smaller projected area. Cone penetrometers with 5 cm² projected area find use in the field applications and even smaller sizes (1 cm²) are used in the laboratory for research purposes. These cones should be designed with dimensions scaled in direct proportion to standard 10-cm² penetrometers. In thinly layered soils, the diameter affects how accurately the layers may be sensed. Smaller diameter cones may sense thinner layers more accurately than larger cones. If there are questions as to the effect of scaling the penetrometer to either larger or smaller size, results can be compared in the field to the 10-cm² penetrometer for soils under consideration. This is because the 10-cm² cone is considered the reference penetrometer for field testing.

7.1.3 *Friction Sleeve*—The outside diameter of the manufactured friction sleeve and the operating diameter are equal to the diameter of the base of the cone with a tolerance of +0.35 mm and –0.0 mm. The friction sleeve is made from high strength steel of a type and hardness to resist wear due to abrasion by soil. Chrome-plated steel is not recommended due to differing frictional behavior. The surface area of the friction sleeve is 150 cm² ± 2 %, for a 10-cm² cone. If the cone base area is increased to 15 cm², as provided for in 7.1.2.1, the surface area of the friction sleeve should be adjusted proportionally, with the same length to diameter ratio as the 10-cm² cone. With the 15-cm² tip, a sleeve area of 225 cm² is similar in scale.

7.1.3.1 The top diameter of the sleeve must not be smaller than the bottom diameter or significantly lower sleeve resistance will occur. During testing, the top and bottom of the sleeve should be periodically checked for wear with a micrometer. Normally, the top of the sleeve will wear faster than the bottom.

7.1.3.2 Friction sleeves must be designed with equal end areas which are exposed to water pressures (2(4, 35, 46, 57, 68)). This will remove the tendency for unbalanced end forces to act on the sleeve. Sleeve design must be checked in accordance with A1.7 to ensure proper response.

7.1.4 *Gap*—The gap (annular space) between the cylindrical extension of the cone base and the other elements of the penetrometer tip should be kept to the minimum necessary for operation of the sensing devices and should be designed and constructed in such a way to prevent the entry of soil particles. Gap requirements apply to the gaps at either end of the friction sleeve and to other elements of the penetrometer tip.

7.1.4.1 The gap between the cylindrical extension of the cone base and other elements of the penetrometer tip, e_c , must not be larger than 5 mm for the friction cone penetrometer.

7.1.4.2 If a seal is placed in the gap, it should be properly designed and manufactured to prevent entry of soil particles into the penetrometer tip. It must have a deformability at least two orders of magnitude greater than the material comprising the load transferring components of the sensing devices in order to prevent load transfer from the tip to the sleeve.

7.1.4.3 *Filter Element in the Gap*—If a filter element for a piezocone is placed in the gap between cone and sleeve the sum of the height of cylindrical extension, h_e , plus element thickness filling the gap, e_e , can range from 8 to 20 mm (see 7.1.8 for explanation).

7.1.5 *Diameter Requirements*—The friction sleeve should be situated within 5 to 15 mm behind the base of the cone tip. The annular spaces and seals between the friction sleeve and other portions of the penetrometer tip must conform to the same specifications as described in 7.1.4. Changes in the diameter of the penetrometer body above the friction sleeve should be such that tip or sleeve measurements are not influenced by increases in diameter. International reference test procedures require that the penetrometer body have the same diameter as the cone for the complete length of the penetrometer body (35, 79, 810).

7.1.5.1 For some penetrometer designs, it may be desirable to increase the diameter of the penetrometer body to house additional sensors or reduce friction along push rods. These diameter changes are acceptable if they do not have significant influence on tip and sleeve data. If there is question regarding a specific design with diameter increases, comparison studies can be made to a penetrometer with constant diameter. Information on diameters of the complete penetrometer body should be reported.

NOTE 3—The effects caused by diameter changes of the penetrometer on tip and sleeve resistance are dependent on the magnitude of diameter increase and location on the penetrometer body. Most practitioners feel that diameter increases equivalent to addition of a friction reducer with area increases of 15 to 20 % should be restricted to a location at least eight to ten cone diameters behind the friction sleeve.

7.1.6 The axis of the cone, the friction sleeve (if included), and the body of the penetrometer tip must be coincident.

7.1.7 *Force Sensing Devices*—The typical force sensing device is a strain gauge load cell that contains temperature compensated bonded strain gages. The configuration and location of strain gages should be such that measurements are not influenced by possible eccentricity of loading.

7.1.8 *Electronic Piezocone Penetrometer*—A piezocone penetrometer can contain porous filter element(s), pressure transducer(s), and fluid filled ports connecting the elements to the transducer to measure pore water pressure. Fig. 3 shows the common design types used in practice including: 10-cm² friction-type, type 1 and type 2 piezocone, and 15-cm² size. The standard penetrometer should be the type 2 piezocone with filter located at the shoulder (both 10-cm² and 15-cm²) to allow correction of tip resistances. The electric friction penetrometer without porewater transducers can be used in soils with minor porewater pressure

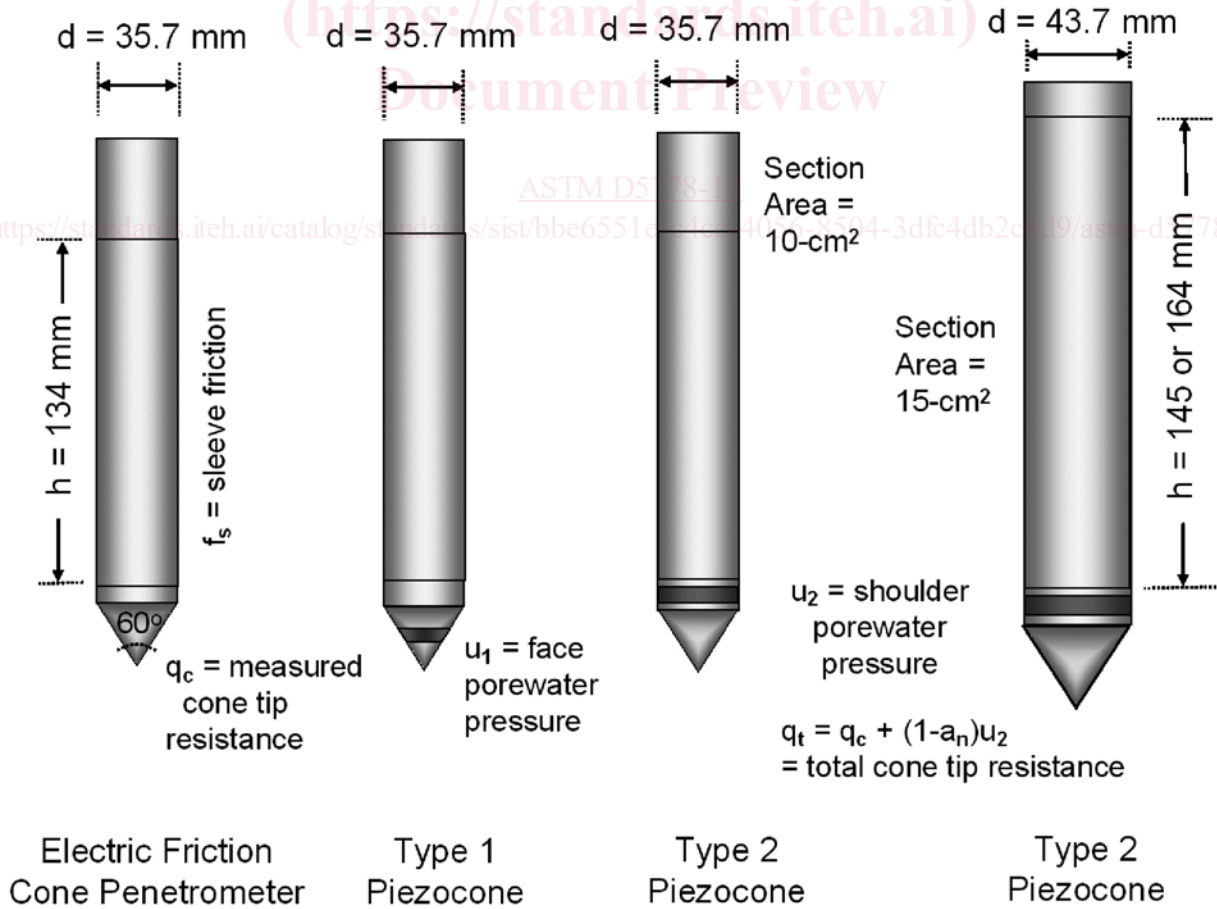

FIG. 3 Penetrometer Design Configurations: (a) Electronic Friction-type, (b) Type 1 Piezocone, (c) Standard 10-cm² Type 2 Piezocone, and (d) 15-cm² Type 2 Version (57)

development, such as clean sands, granular soils, as well as soils and fills well above the groundwater table. The type 1 with face filter element finds use in fissured geomaterials and materials prone to desaturation, as well as dissipation readings. Numerous design and configuration aspects can affect the measurement of dynamic water pressures. Variables such as the element location, design and volume of ports, and the type and degree of saturation of the fluids, cavitation of the element fluid system and resaturation lag time, depth and saturation of soil during testing all affect the dynamic porewater pressure measured during testing and dissipation tests of dynamic pressures (**1, 2, 3, 68**). It is beyond the scope of the procedure to address all of these variables. As a minimum, complete information should be reported as to the design, configuration, and the preparation of the piezocone system that is used for the particular sounding.

7.1.8.1 Measurement of hydrostatic water pressures during pauses in testing are more straightforward. The presence of air entrained in the system only affects dynamic response. In high permeability soils (that is, clean sands), hydrostatic pressures will equalize within seconds or minutes. In low permeability materials such as high plasticity clays, equalization can take many hours. If the goal of the exploration program is only to acquire hydrostatic pressures in sands, some of the preparation procedures for dynamic pressure measuring can be relaxed, such as deairing fluids.

7.1.8.2 The porewater pressure measurement locations of the porous element are limited to the face or tip of the cone, u_1 , directly behind the cylindrical extension of the base of the cone, u_2 , or behind the sleeve, u_3 . Some penetrometers used for research purposes may have multiple measurement locations.

7.1.8.3 There are several advantages to locating the porous element immediately behind the tip of the cone in location u_2 , primarily the required correction of measured q_c to total tip stress, q_t , as detailed extensively (**1-6(3-8)**). Also, the element is less subject to damage and abrasion, as well as fewer compressibility effects (**4(3, 68)**). Elements located in the u_2 location may be subject to cavitation at shallow depths in dense sands because the zone behind the height of cylindrical extension is a zone of dilation in drained soils. Similar response can occur in stiff fissured clays and crusts (**4(3)**). Porewater pressure measurements obtained at the u_1 face location are more effective for compressibility determinations and layer detection, particularly in fissured soils, but are more subject to wear (**9(2, 11)**). At the u_2 location, a minimum 2-mm cylindrical extension of the cone tip (h_c) should be maintained for protection of the cone. Typical filter element thickness at all locations in the horizontal plane ranges from 5 to 10 mm.

7.1.8.4 The miniature diaphragm-type electronic pressure transducer is normally housed near the tip of the cone. For dynamic pressure measurements, the filter and ports are filled with deaired fluid to measure dynamic porewater pressure response. The volume of connecting ports to the transducer should be minimized to facilitate dynamic pressure response. These electronic transducers are normally very reliable, accurate, and linear in response. The transducer shall have a precision of at least ± 14 kPa (± 2 psi). The porewater-pressure transducer must meet requirements given in 10.2.

7.1.8.5 *Element*—The element is a fine porous filter made from plastic, sintered steel or bronze, or ceramic. Typical pore size is between 20 to 200 microns (**68, 911**). Different materials have different advantages. Smearing of metallic element openings by hard soil grains may reduce dynamic response of the system, thus normally not used for face elements but best suited for shoulder filter positions. Ceramic elements are very brittle and may crack when loaded, but perform well on the cone face as they reduce compressibility concerns. Polypropylene plastic elements are most commonly used in practice, particularly at the shoulder. Plastic filters (as high-density polyethylene, HDPE, or high-density polypropylene, HDPP) may be inappropriate for environmental type CPTs where contaminant detection is sought. Typically, the filter element is wedged at the tip or midface (u_1) location, or located at the shoulder in the gap immediately above the cone extension (designated u_2) location. At these locations, it is important to design the penetrometer such that compression of the filter elements is minimized.

7.1.8.6 *Fluids for Saturation*—Glycerine, or alternatively silicone oil, is most often used for deairing elements for dynamic response. These stiff viscous oils have less tendency to cavitate, although cavitation may be controlled by the effective pore size of the element mounting surfaces. Water can be used for the fluid if the entire sounding will be submerged, or if dynamic response is not important. The fluids are deaired using procedures described in 11.2.

7.2 *Measuring System*—The signals from the penetrometer transducers are to be displayed at the surface during testing as a continuously updated plot against depth. The data are also to be recorded electronically for subsequent processing. Electronic recording shall be digital and use at least twelve bit (one part in 4096) resolution in the analog to digital conversion, although 16-bit resolution and higher may be preferable in very soft ground. Either magnetic (disk or tape) or optical (disk) non-volatile storage may be used. In analog systems, the temperature stability and accuracy of the A-to-D converter shall be such that the overall cone-transmission-recording system complies with calibration requirements set forth in the annex.

7.2.1 Use of analog systems is acceptable but the system resolution may be lower than requirements in the annex and Section 10. Use of an analog recorder as a supplement to digital system is advantageous because it can provide system backup.

NOTE 46—Depending upon the equipment, data stored digitally on magnetic drives, tapes, floppy disks, or other media are often used. The data files should include project, location, operator, and data format information (for example, channel, units, corrected or uncorrected, etc.) so that the data can be understood when reading the file with a text editor.

7.3 *Push Rods*—Steel rods are required having a cross sectional area adequate to sustain, without buckling, the thrust required to advance the penetrometer tip. For penetrometers using electrical cables, the cable is prestrung through the rods prior to testing. Push rods are supplied in 1-meter lengths. The push rods must be secured together to bear against each other at the joints and form a rigid-jointed string of push rods. The deviation of push rod alignment from a straight axis should be held to a minimum,

especially in the push rods near the penetrometer tip, to avoid excessive directional penetrometer drift. Generally, when a 1-m long push rod is subjected to a permanent circular bending resulting in 1 to 2 mm of center axis rod shortening, the push rod should be discarded. This corresponds to a horizontal deflection of 2 to 3 mm at the center of bending. The locations of push rods in the string should be varied periodically to avoid permanent curvature.

7.3.1 For the 10-cm² penetrometer, standard 20-metric ton high tensile strength steel push rods are 36-mm outside diameter, 16-mm inside diameter, and have a mass per unit length of 6.65 kg/m. For 15-cm² penetrometers, the test may be pushed with 44.5-mm outside diameter rods or with standard rods used for the 10-cm² penetrometer.

7.4 *Friction Reducer*—Friction reducers are normally used on the push rods to reduce rod friction. If a friction reducer is used, it should be located on the push rods no closer than 0.5 m behind the base of the cone. Friction reducers, that increase push rod outside diameter by approximately 25 %, are typically used for 10-cm² cones. If a 15-cm² penetrometer is advanced with 36-mm push rods there may be no need for friction reducers since the penetrometer itself will open a larger hole. The type, size, amount, and location of friction reducer(s) used during testing must be reported.

7.5 *Thrust Machine and Reaction*—The thrust machine will provide a continuous stroke, preferably over a distance greater than 1 m. The thrust machine should be capable of adjusting push direction through the use of a leveling system such that push initiates in a vertical orientation. The machine must advance the penetrometer tip and push rods at a smooth, constant rate (see 12.1.2) while the magnitude of thrust can fluctuate. The thrust machine must be anchored or ballasted, or both, so that it provides the necessary reaction for the penetrometer and does not move relative to the soil surface during thrust.

NOTE 5—**Cone 7—Cone** penetration soundings usually require thrust capabilities ranging from 100 to 200 kN (11 to 22 tons) for full capacity. High mass ballasted vehicles can cause soil surface deformations which may affect penetrometer resistance(s) measured in near surface layers. Anchored or ballasted vehicles, or both, may induce changes in ground surface reference level. If these conditions are evident, they should be noted in reports.

7.6 *Other Sensing Devices*—Other sensing devices can be included in the penetrometer body to provide additional information during the sounding. These instruments are normally read at the same continuous rate as tip, sleeve, and porewater pressure sensors, or alternatively, during pauses in the push (often at 1-m rod breaks). Typical sensors are inclinometer, temperature, resistivity (or its reciprocal, electrical conductivity), or seismic sensors, such as geophones that can be used to obtain downhole shear wave velocity. These sensors should be calibrated if their use is critical to the investigation program. The use of an inclinometer is highly recommended since it will provide information on potentially damaging situations during the sounding process. An inclinometer can provide a useful depth reliability check because it provides information on verticality. The configuration and methods of operating such sensors should be reported.

8. Reagents and Materials

8.1 *O-Ring Compound*—A petroleum or silicon compound for facilitating seals with O-rings. Use of silicon compounds may impede repair of strain gages if the strain gauge surface is exposed to the compound.

8.2 *Glycerine*, or $\text{CHOH}(\text{CH}_2\text{OH})_2$, for use in porewater pressure measurement systems. Approximately 95 % pure glycerine can be procured from most drug stores.

8.3 *Silicone Oil (or fluid)*, for use in porewater pressure measurement systems. This material is available in varying viscosities ranging from 1400 to 10 000 CP.

NOTE 6—Detailed comparisons and discussions on the use of these fluids can be found elsewhere (**68, 911**).

9. Hazards

9.1 *Technical Precautions—General* :

9.1.1 Use of penetrometer components that do not meet required tolerances or show visible signs of non-symmetric wear can result in erroneous penetration resistance data.

9.1.2 The application of thrust in excess of rated capacity of the equipment can result in damage to equipment (see Section 6).

9.1.3 A cone sounding must not be performed any closer than 25 borehole diameters from any existing unbackfilled or uncased bore hole.

9.1.4 When performing cone penetration testing in prebored holes, an estimate of the depth below the prebored depth which is disturbed by drilling, should be made and penetration resistance data obtained in this zone should be noted. Usually, this depth of disturbance is assumed to be equal to at least three borehole diameters.

9.1.5 Significant bending of the push rods can influence penetration resistance data. The use of a tubular rod guide is recommended at the base of the thrust machine and also in prebored holes to help prevent push rod bending.

9.1.6 Push rods not meeting requirements of 7.3 may result in excessive directional penetrometer drift and possibly unreliable penetration resistance values.

9.1.7 Passing through or alongside obstructions may deflect the penetrometer and induce directional drift. Note any indications of encountering such obstructions, such as gravels, and be alert for possible subsequent improper penetrometer tip operation.

9.1.8 If the proper rate of advance of the penetrometer is not maintained for the entire stroke through the measurement interval, penetration resistance data will be erroneous.

9.2 *Technical Precautions—Electronic Friction Cone Penetrometer*:

9.2.1 Failure of O-ring seals can result in damage to or inaccurate readings from electronic transducers. The O-ring seals should

be inspected regularly, after each sounding, for overall condition, cleanliness and watertightness.

9.2.2 Soil ingress between different elements of a penetrometer tip can result in unreliable data. Specifically, soil ingress will detrimentally affect sleeve resistance data. Seals should be inspected after each sounding, maintained regularly, and replaced when necessary. If very accurate sleeve resistance data is required, it is recommended to clean all seals after each sounding.

9.2.3 Electronic cone penetrometer tips should be temperature compensated. If extreme temperatures outside of the range established in A1.3.3 are to be encountered, the penetrometer should be checked for the required temperature range to establish they can meet the calibration requirements. Also, harsh environments may severely affect the data acquisition system of power supplies, notebook or field computers, and other electronics.

9.2.4 If the shift in baseline reading after extracting the penetrometer tip from the soil is so large that the conditions of accuracy as defined in 10.1.2.1 are no longer met, penetration resistance data should be noted as unreliable. If baseline readings do not conform to allowable limits established by accuracy requirements in 10.1.2.1, the penetrometer tip must be repaired, and recalibrated or replaced.

9.2.5 Electronic friction cone penetrometers having unequal end areas on their friction sleeves can yield erroneous f_s readings because of dynamic porewater pressures acting unevenly on the sleeve (2(4, 35, 4-6, 8). Friction sleeve design should be checked in accordance with A1.7 to ensure balanced response. The response is also dependent on location of water seals. If O-ring water seals are damaged during testing, and sleeve data appear affected, the sounding data should be noted as unreliable and the seals should be repaired.

9.3 *Piezocone Penetrometer*—The electronic piezocone penetrometer tip measures pore water pressures on the exterior of the penetrometer tip by transferring the pressure through a de-aired fluid system to a pressure transducer in the interior of the tip. For proper dynamic response, the measurement system (consisting of fluid ports and porous element) must be completely saturated prior to testing. Entrained air must be removed from the fluid-filled system or porewater pressure fluctuation during penetrometer tip advancement will be incorrect due to response lag from compression of air bubbles (see 11.2, 12.3.2, and 12.3.3). For soundings where dynamic response is important, the prepared filter elements should be replaced after every sounding.

10. Calibration and Standardization

10.1 *Electronic Friction Cone Penetrometers:*

10.1.1 The requirements for newly manufactured or repaired cone penetrometers are of importance. Newly manufactured or repaired electronic cone penetrometers are to be checked to meet the minimum calibration requirements described in the annex. These calibrations include load tests, thermal tests, and mechanical tests for effects of imbalanced hydrostatic forces. Calibration procedures and requirements given in the annex are for subtraction-type cone penetrometers. Calibration requirements for independent-type cone penetrometers should equal or exceed those requirements. The calibration records must be certified as correct by a registered professional engineer or other responsible engineer with knowledge and experience in materials testing for quality assurance. Applied forces or masses must be traceable to calibration standard forces or masses retained by the National Institute of Standards and Technology (NIST), formerly the National Bureau of Standards. For description of calibration terms and methods for calibrating, refer to the annex.

10.1.2 *Baseline Readings*—Baseline or zero-load readings for both cone and friction sleeve load cells and porewater pressure transducers must be taken before and after each sounding. The baseline reading is a reliable indicator of output stability, temperature-induced apparent load, soil ingress, internal friction, threshold sensitivity, and unknown loading during zero setting. Take the initial baseline reading after warming electrical circuits according to the manufacturer's instructions, generally for 15 to 30 min, and in a temperature environment as close as possible to that of the material to be sounded. If temperature is of concern, immerse the penetrometer tip in a bucket of fresh tap water, or insert the penetrometer tip in the ground while electrically warming circuits to stabilize its temperature and then extracted for rapid determination of initial baseline. After a sounding is completed, take a final baseline. The change in initial and final baseline values should not exceed 2 % FSO for the cone tip, sleeve, and pressure transducer.

10.1.2.1 Maintain a continuous record of initial and final baselines during production testing. After each sounding, compare the final baseline to the initial baseline for agreement within the tolerances noted above. In some cases during heavy production testing where the cone is not disassembled and cleaned after each sounding, the initial baseline for the next sounding can serve as the final baseline to the previous sounding as long as agreement is within allowable limits.

10.1.2.2 If the post sounding baseline shift exceeds above criteria, inspect the cone for damage by inspecting the tip and checking to see that the sleeve can be rotated by hand. If there is apparent damage, replace parts as required. Clean the cone and allow temperatures to equalize to presounding conditions, and obtain a new baseline. If this value agrees with the initial baseline within the above criteria, a load range calibration check is not required. If the pre and post baselines are still not within the above criteria then it is likely that the shift was caused by an obstacle or obstruction and linearity should be checked with a load range calibration.

10.1.2.3 If the baseline shift still exceeds the above criteria, perform a load range calibration as described in 10.1.2.1. If the cone load cell baseline shift exceeds 2 % FSO, the cone is likely damaged and will not meet load range criteria in 10.1.2.2. Sleeve load cell baseline shifts for subtraction-type penetrometers usually can exceed 2 % FSO and still meet load range criteria.

10.1.2.4 Report data for the sounding where unacceptable baseline shift occurs as unreliable. In some cases it may be obvious

where the damage occurred and data prior to that point may be considered reliable. The location where obvious damage occurred should be clearly noted in reports.

10.1.3 *Penetrometer Wear and Usage*

10.1.3.1 For penetrometers used regularly during production, periodic load range checks should be performed. The inspection period can be based on production footage such as once every lineal 3000 m (approx. 10^4 linear feet) of soundings. If field load range equipment is not available, the penetrometer may be checked in the laboratory at the end of a project.

10.1.3.2 For penetrometers that are used infrequently, a periodic check may be based on time period, such as once every year. If a penetrometer has not been used for a long period of time, checking it before use is advisable.

10.1.3.3 For projects requiring a high level of quality assurance, it may be required to do load range checks before and after the project.

10.1.3.4 Load range calibrations are required if the initial and final baselines for a sounding do not meet requirements given in 10.1.2.1.

10.1.3.5 Records documenting the history of an individual penetrometer should be maintained for evaluation of performance.

10.2 *Porewater Pressure Transducer*—Calibrate newly manufactured or repaired transducers in accordance with requirements in the annex. During production, the transducer should be calibrated at regularly scheduled intervals and whenever linear performance is suspect. The reference gauge can be a Bourdon tube pressure gauge, or electronic pressure transducer that is calibrated annually to NIST traceable loading device (dead weight testing apparatus).

10.2.1 Prior to testing, baseline values or initial zeroing of the transducer is performed on the porewater pressure transducer at ambient air pressures at the surface. Maintain records as to the baseline values for the transducer in similar fashion to those for tip and sleeve resistance. If significant changes in baseline values occur, normally 1 to 2 % FSO, perform load range tests to check for possible damage and nonlinear response.

10.3 *Calibrations of Other Sensing Devices*—Calibration data for other sensors in the penetrometer body may require calibrations using procedures similar to those given in the annex for load cells and pressure transducers. The need for calibration depends on the requirements of the individual investigation program. For noncritical programs, the occurrence of reasonable readings may be sufficient. In critical programs, it may be necessary to load the sensor through the range of interest with reference standards to ensure accurate readings.

11. Conditioning

11.1 Power electronic cone penetrometer and data acquisition systems for a minimum time period to stabilize electric circuits before performing soundings. Power the system to manufacturer's recommendations prior to obtaining reference baselines. For most electronic systems this time period is 15 to 30 min.

11.2 Electronic piezocone penetrometer soundings require special preparation of the transmitting fluid and porous elements such that entrained air is removed from the system. For soundings where dynamic response is important, replace the prepared filter elements and the ports flushed after every sounding. Some of the techniques discussed below have been successful for preparation of elements. Regardless of the techniques used, report the equipment and methods.

11.2.1 Field or laboratory tests can be performed to evaluate assembled system response, if desired. Place the cone tip and element in a pressurized chamber and subject to rapid pressure change. Compare the response of the system to the applied pressure changes and if responses match, the system is properly prepared.

11.2.2 Place elements in a pure glycerine or silicone oil bath under a vacuum of at least 90 % of one atmosphere (-90 kPa). Maintain vacuum until air bubble generation is reduced to a minimum. Application of ultrasonic vibration and low heat ($T < 50^\circ\text{C}$) will assist in removal of air. Generally with use of combined vacuum, ultrasonic vibration, and low heat, filter elements can be deaired in about 4 h, although it is best to allow for 24 h to ensure best performance. Results will depend upon the viscosity of the fluid and pore size of the filter element.

11.2.3 Elements can be prepared in water by boiling the elements while submerged in water for at least 4 h, although damage may result from prolonged exposure in this approach ~~(1)(3)~~.

11.2.4 *Other Suitable Means*—Report other techniques, such as commercially-purchased pre-saturated filter elements that are available, or grease-filled slot ~~(2)(4, 57)~~.

11.2.5 *Storage*—Store prepared elements submerged in the prepared fluid until ready for use. Fill the containers and evacuate during storage. Allowable storage length depends on the fluid. If elements are prepared in water they must be deaired again one day after containers are opened and exposed to air. Elements stored in glycerine or silicone may be stored for longer periods, up to several months, after storage containers have been exposed to air.

12. Procedure

12.1 *General Requirements:*

12.1.1 Prior to beginning a sounding, perform site surveys to ensure hazards such as overhead and underground utilities will not be encountered. Position the thrust machine over the location of the sounding, and lower leveling jacks to raise the machine mass off the suspension system. Set the hydraulic rams of the penetrometer thrust system to as near vertical as possible. The axis of the push rods must coincide with the thrust direction.

12.1.2 Set the hydraulic ram feed rate to advance the penetrometer at a rate of 20 ± 5 mm/s for all electronic cone