

DRAFT INTERNATIONAL STANDARD

ISO/DIS 15792-1

ISO/TC 44/SC 3

Secretariat: ANSI

Voting begins on:
2019-10-17

Voting terminates on:
2020-01-09

Welding consumables — Test methods —

Part 1:

Test methods for all-weld metal test specimens in steel, nickel and nickel alloys

Produits consommables pour le soudage — Méthodes d'essai —

Partie 1: Méthodes d'essai pour les éprouvettes de métal fondu hors dilution pour le soudage de l'acier, du nickel et des alliages de nickel

ICS: 25.160.20

iTeh STANDARD PREVIEW
(standards.iteh.ai)
Full standard:
<https://standards.iteh.ai/catalog/standards/sist/500eb04f-e76d-45f2-ae9a-b96fb1bd6e72/iso-fdis-15792-1>

THIS DOCUMENT IS A DRAFT CIRCULATED FOR COMMENT AND APPROVAL. IT IS THEREFORE SUBJECT TO CHANGE AND MAY NOT BE REFERRED TO AS AN INTERNATIONAL STANDARD UNTIL PUBLISHED AS SUCH.

IN ADDITION TO THEIR EVALUATION AS BEING ACCEPTABLE FOR INDUSTRIAL, TECHNOLOGICAL, COMMERCIAL AND USER PURPOSES, DRAFT INTERNATIONAL STANDARDS MAY ON OCCASION HAVE TO BE CONSIDERED IN THE LIGHT OF THEIR POTENTIAL TO BECOME STANDARDS TO WHICH REFERENCE MAY BE MADE IN NATIONAL REGULATIONS.

RECIPIENTS OF THIS DRAFT ARE INVITED TO SUBMIT, WITH THEIR COMMENTS, NOTIFICATION OF ANY RELEVANT PATENT RIGHTS OF WHICH THEY ARE AWARE AND TO PROVIDE SUPPORTING DOCUMENTATION.

This document is circulated as received from the committee secretariat.

ISO/CEN PARALLEL PROCESSING



Reference number
ISO/DIS 15792-1:2019(E)

© ISO 2019

iTeh STANDARD PREVIEW
(standards.iteh.ai)
Full standard:
<https://standards.iteh.ai/catalog/standards/sist/500eb04f-e76d-45f2-ae9a-b96fb1bd6e72/iso-fdis-15792-1>



COPYRIGHT PROTECTED DOCUMENT

© ISO 2019

All rights reserved. Unless otherwise specified, or required in the context of its implementation, no part of this publication may be reproduced or utilized otherwise in any form or by any means, electronic or mechanical, including photocopying, or posting on the internet or an intranet, without prior written permission. Permission can be requested from either ISO at the address below or ISO's member body in the country of the requester.

ISO copyright office
CP 401 • Ch. de Blandonnet 8
CH-1214 Vernier, Geneva
Phone: +41 22 749 01 11
Fax: +41 22 749 09 47
Email: copyright@iso.org
Website: www.iso.org

Published in Switzerland

Contents

	Page
Foreword.....	iv
Introduction.....	v
1 Scope.....	1
2 Normative references.....	1
3 Terms and definitions.....	1
4 General requirements.....	1
5 Test plate material.....	1
6 Preparation of test piece.....	2
7 Welding conditions.....	2
8 Heat treatment.....	3
9 Position of test specimens and test specimen dimensions.....	3
10 Retests.....	4
11 Test report.....	4

iTeh STANDARD PREVIEW
(standards.iteh.ai)

Full standard:
<https://standards.iteh.ai/catalog/standards/sist/500eb04f-e76d-45f2-ae9a-b96fb1bd6e72/iso-fdis-15792-1>

Foreword

ISO (the International Organization for Standardization) is a worldwide federation of national standards bodies (ISO member bodies). The work of preparing International Standards is normally carried out through ISO technical committees. Each member body interested in a subject for which a technical committee has been established has the right to be represented on that committee. International organizations, governmental and non-governmental, in liaison with ISO, also take part in the work. ISO collaborates closely with the International Electrotechnical Commission (IEC) on all matters of electrotechnical standardization.

The procedures used to develop this document and those intended for its further maintenance are described in the ISO/IEC Directives, Part 1. In particular, the different approval criteria needed for the different types of ISO documents should be noted. This document was drafted in accordance with the editorial rules of the ISO/IEC Directives, Part 2 (see www.iso.org/directives).

Attention is drawn to the possibility that some of the elements of this document may be the subject of patent rights. ISO shall not be held responsible for identifying any or all such patent rights. Details of any patent rights identified during the development of the document will be in the Introduction and/or on the ISO list of patent declarations received (see www.iso.org/patents).

Any trade name used in this document is information given for the convenience of users and does not constitute an endorsement.

For an explanation of the voluntary nature of standards, the meaning of ISO specific terms and expressions related to conformity assessment, as well as information about ISO's adherence to the World Trade Organization (WTO) principles in the Technical Barriers to Trade (TBT), see www.iso.org/iso/foreword.html.

This document was prepared by Technical Committee ISO/TC 44, *Welding and allied processes*, Subcommittee SC 3, *Welding consumables*.

Any feedback or questions on this document should be directed to the user's national standards body. A complete listing of these bodies can be found at www.iso.org/members.html.

Official interpretations of TC 44 documents, where they exist, are available from this page: <https://committee.iso.org/sites/tc44/home/interpretation.html>.

This second edition cancels and replaces the first edition (ISO 15792-1:2000 and ISO 15792-1:2000/Amd, 1), which has been technically revised.

The main changes compared to the previous edition are as follows:

Introduction

It should be noted that the mechanical properties of all-weld metal test specimens used to classify welding consumables can vary from those obtained in production joints because of differences in welding procedure such as electrode diameter, width of weave, welding position and material composition.

Test conditions prescribed and results required should not be considered to be requirements or expectations for a procedure qualification.

iTeh STANDARD PREVIEW
(standards.iteh.ai)

Full standard:
<https://standards.iteh.ai/catalog/standards/sist/500eb04f-e76d-45f2-ae9a-b96fb1bd6e72/iso-fdis-15792-1>

iTeh STANDARD PREVIEW
(standards.iteh.ai)

Full standard:
<https://standards.iteh.ai/catalog/standards/sist/500eb04f-e76d-45f2-ae9a-b96fb1bd6e72/iso-fdis-15792-1>

Welding consumables — Test methods —

Part 1:

Test methods for all-weld metal test specimens in steel, nickel and nickel alloys

1 Scope

This document specifies the preparation of test pieces and specimens. The purpose is to determine mechanical properties of all-weld metal where required by the consumable classification standard or for other purposes, in arc welding of steel, nickel and nickel alloys.

This document is not applicable to single- or two-run welding or fillet welding. For these cases, ISO 15792-2 and ISO 15792-3 apply.

2 Normative references

The following documents are referred to in the text in such a way that some or all of their content constitutes requirements of this document. For dated references, only the edition cited applies. For undated references, the latest edition of the referenced document (including any amendments) applies.

ISO 5178, *Destructive tests on welds in metallic materials — Longitudinal tensile test on weld metal in fusion welded joints*

ISO 9016:2010, *Destructive tests on welds in metallic materials — Impact tests — Test specimen location, notch orientation and examination*

ISO 13916:1996, *Welding — Measurement of preheating temperature, interpass temperature and preheat maintenance temperature*

3 Terms and definitions

No terms and definitions are listed in this document.

The list below is always included after each option:

ISO and IEC maintain terminological databases for use in standardization at the following addresses:

- ISO Online browsing platform: available at <https://www.iso.org/obp>
- IEC Electropedia: available at <http://www.electropedia.org/>

4 General requirements

Welding consumables to be tested shall be representative of the manufacturer's products to be classified or tested. Test pieces shall be prepared as described below.

5 Test plate material

The material to be used for the test piece shall be compatible with the weld metal provided by the welding consumable tested. Alternatively, the groove edges and the backing strip shall be built up with at least two layers using the welding consumable being tested.

6 Preparation of test piece

The test piece shall be prepared in the form of a single V-groove on a backing strip. The backing strip shall be tack welded to the test piece on the reverse side. See Figure 1 and Table 1.

The plates of the test piece shall be pre-set or restrained in such a way that a sufficiently flat test piece is produced for extraction of specimens. The welded test piece shall not be straightened.

The type of test piece defines the dimensions, see Table 1. The type selected for classification purpose is specified in the relevant consumable standard.

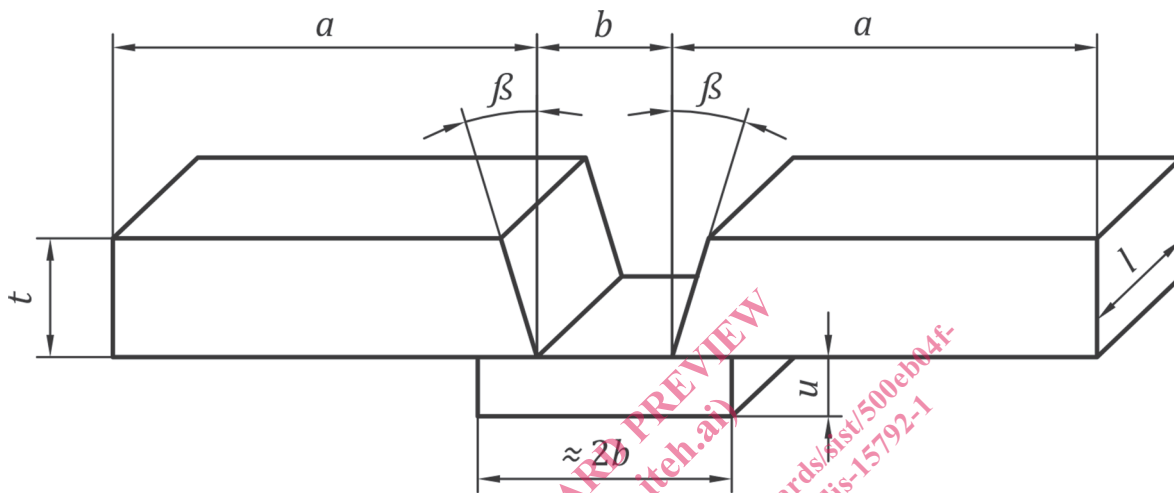

Figure 1 — Test piece dimensions

Table 1 — Type and dimensions of the test piece

Dimensions in millimetres

Type	t	a	b	u	b Degree	l
1.0	12	≥ 80	10			
1.1	12	≥ 90	12			
1.2	16	≥ 100	14			
1.3	20 +1,0	≥ 125	16 +1,0	≥ 6	10 +2,5	≥ 150
1.4	25 -1,0	≥ 125	20 -0		-0	
1.5	30	≥ 200	25			
1.6	20	≥ 150	20			
1.7	25	≥ 150	24			

7 Welding conditions

The test piece shall be welded in the flat position except for consumables which are designed exclusively for welding in another position in which case that position shall be used for welding. The welding shall be started after applying any preheating requirements given in the consumable standard. The interpass temperature shall also be in accordance with the consumable standard.

The preheat and interpass temperatures shall be measured using temperature indicator crayons, surface thermometers or thermocouples, see ISO 13916.

The welding conditions used, such as current, voltage, travel speed, weld run sequence, weld bead size, shall be in accordance with the limits specified in the relevant consumable standard.

8 Heat treatment

All heat treatments required for the weld metal, except hydrogen removal treatment, shall be carried out on the test piece, or on sections thereof with a machining allowance.

The heat treatments are specified in standards relating to welding consumables.

Hydrogen removal treatment may be carried out on the test piece for tensile testing before or after final machining. The test piece may be held at a temperature not exceeding 250 °C for up to 16 h.

9 Position of test specimens and test specimen dimensions

Figures 2 and 3 respectively show the position of the tensile test specimen and of the notched impact specimen. The test pieces shall be divided by cutting (machining) or by thermal cutting. In the case of thermal cutting, machining allowances of 10 mm at least on either side shall be provided for the subsequent machining of the specimens.

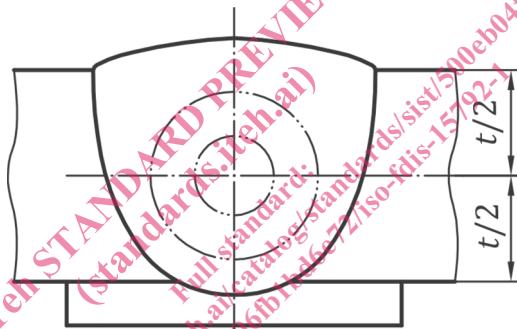

Figure 2 — Position of the tensile specimen in the test piece

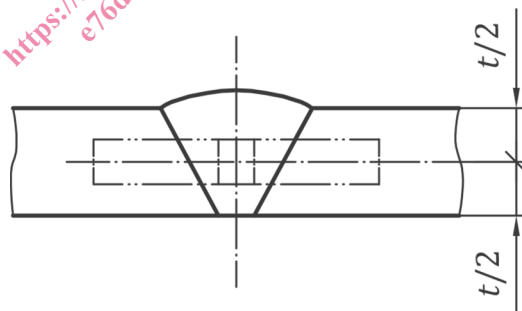

Figure 3 — Position of the notched bar impact specimen in the test pieces

The tensile test specimens shall be in accordance with ISO 5178. Apart from type 1.0 and 1.1 test pieces, for which the diameter shall be 8 mm, the specimens shall have a diameter of 10 mm in the gauge length.

The impact specimens shall be in accordance with the designation VWT 0/b in ISO 9016:2010. The position of the impact specimen shall be at the midline of the plate thickness.

The size of impact specimens shall be 10 mm ´ 10 mm.