



**International
Standard**

ISO 24664

**Refrigerating systems and heat
pumps — Pressure relief devices
and their associated piping —
Methods for calculation**

*Systèmes de réfrigération et pompes à chaleur — Dispositifs de
limitation de pression et tuyauteries associées — Méthodes de calcul*

**First edition
2024-11**

Iteh Standards
iteh.ai
Document Preview

[ISO 24664:2024](https://standards.iteh.ai/catalog/standards/iso/ba716ec7-01a0-4502-bf94-feca685c0366/iso-24664-2024)

<https://standards.iteh.ai/catalog/standards/iso/ba716ec7-01a0-4502-bf94-feca685c0366/iso-24664-2024>

iTeh Standards
(<https://standards.iteh.ai>)
Document Preview

[ISO 24664:2024](https://standards.iteh.ai/catalog/standards/iso/ba716ec7-01a0-4502-bf94-feca685c0366/iso-24664-2024)

<https://standards.iteh.ai/catalog/standards/iso/ba716ec7-01a0-4502-bf94-feca685c0366/iso-24664-2024>



COPYRIGHT PROTECTED DOCUMENT

© ISO 2024

All rights reserved. Unless otherwise specified, or required in the context of its implementation, no part of this publication may be reproduced or utilized otherwise in any form or by any means, electronic or mechanical, including photocopying, or posting on the internet or an intranet, without prior written permission. Permission can be requested from either ISO at the address below or ISO's member body in the country of the requester.

ISO copyright office
CP 401 • Ch. de Blandonnet 8
CH-1214 Vernier, Geneva
Phone: +41 22 749 01 11
Email: copyright@iso.org
Website: www.iso.org

Published in Switzerland

Contents

Page

Foreword	iv
Introduction	v
1 Scope	1
2 Normative references	1
3 Terms and definitions	1
4 Symbols	3
5 General	4
6 Minimum required discharge capacity for protection of parts of a refrigerating system	5
6.1 General.....	5
6.2 Excessive pressure caused by heat sources.....	6
6.2.1 External heat sources.....	6
6.2.2 Internal heat sources.....	7
6.3 Excessive pressure caused by compressors.....	7
6.4 Excessive pressure caused by expansion of trapped liquid.....	7
7 Discharge capacity of pressure relief devices	8
7.1 General.....	8
7.2 Discharge capacity of pressure relief valves.....	8
7.3 Discharge capacity of bursting discs.....	9
8 Pressure loss in inlet and outlet lines	10
8.1 General.....	10
8.2 Pressure loss in inlet line.....	10
8.3 Pressure loss in outlet line.....	11
8.4 Total pressure loss.....	12
8.5 Connection of outlets from several pressure relief valves to a common outlet line.....	12
Annex A (normative) Values of factors and properties of refrigerants	14
Annex B (informative) Calculation of flow areas for non-flashing and flashing liquids	21
Annex C (informative) Example calculation for sizing pressure relief devices with corresponding pipes and fittings	24
Annex D (informative) Relief valve outlet line when velocity is higher than speed of sound	31
Bibliography	35

Foreword

ISO (the International Organization for Standardization) is a worldwide federation of national standards bodies (ISO member bodies). The work of preparing International Standards is normally carried out through ISO technical committees. Each member body interested in a subject for which a technical committee has been established has the right to be represented on that committee. International organizations, governmental and non-governmental, in liaison with ISO, also take part in the work. ISO collaborates closely with the International Electrotechnical Commission (IEC) on all matters of electrotechnical standardization.

The procedures used to develop this document and those intended for its further maintenance are described in the ISO/IEC Directives, Part 1. In particular, the different approval criteria needed for the different types of ISO document should be noted. This document was drafted in accordance with the editorial rules of the ISO/IEC Directives, Part 2 (see www.iso.org/directives).

ISO draws attention to the possibility that the implementation of this document may involve the use of (a) patent(s). ISO takes no position concerning the evidence, validity or applicability of any claimed patent rights in respect thereof. As of the date of publication of this document, ISO had not received notice of (a) patent(s) which may be required to implement this document. However, implementers are cautioned that this may not represent the latest information, which may be obtained from the patent database available at www.iso.org/patents. ISO shall not be held responsible for identifying any or all such patent rights.

Any trade name used in this document is information given for the convenience of users and does not constitute an endorsement.

For an explanation of the voluntary nature of standards, the meaning of ISO specific terms and expressions related to conformity assessment, as well as information about ISO's adherence to the World Trade Organization (WTO) principles in the Technical Barriers to Trade (TBT), see www.iso.org/iso/foreword.html.

This document was prepared by Technical Committee ISO/TC 86, *Refrigeration and air-conditioning*, Subcommittee SC 1, *Safety and environmental requirements for refrigerating systems*, in collaboration with the European Committee for Standardization (CEN) Technical Committee CEN/TC 182, *Refrigerating systems, safety and environmental requirements*, in accordance with the Agreement on technical cooperation between ISO and CEN (Vienna Agreement).

Any feedback or questions on this document should be directed to the user's national standards body. A complete listing of these bodies can be found at www.iso.org/members.html.

Introduction

This document is based on EN 13136:2013+A1:2018 and applicable parts of ISO 4126-1:2013, ISO 4126-2:2018 and ISO 21922:2021.

It is suited to the specific requirements, and includes the data, of refrigerating systems. It provides means of satisfying the pressure relief devices requirements of EN 378-2:2016 and ISO 5149-2:2014.

iTeh Standards
(<https://standards.iteh.ai>)
Document Preview

[ISO 24664:2024](https://standards.iteh.ai/catalog/standards/iso/ba716ec7-01a0-4502-bf94-feca685c0366/iso-24664-2024)

<https://standards.iteh.ai/catalog/standards/iso/ba716ec7-01a0-4502-bf94-feca685c0366/iso-24664-2024>

Refrigerating systems and heat pumps — Pressure relief devices and their associated piping — Methods for calculation

1 Scope

This document describes the calculation of:

- mass flow for sizing pressure relief devices for parts of refrigerating systems;
- discharge capacities for pressure relief valves and other pressure relief devices in refrigerating systems including the necessary data for sizing these when relieving to atmosphere or to part of the refrigerating system at lower pressure;
- the pressure loss in the inlet and outlet lines of pressure relief valves and other pressure relief devices and includes the necessary data.

This document specifies the requirements for selection of pressure relief devices to prevent excessive pressure due to internal and external heat sources, the sources of increasing pressure (e.g. compressor, heaters, etc.) and thermal expansion of trapped liquid.

NOTE The term "refrigerating system" used in this document includes heat pumps.

2 Normative references

The following documents are referred to in the text in such a way that some or all of their content constitutes requirements of this document. For dated references, only the edition cited applies. For undated references, the latest edition of the referenced document (including any amendments) applies.

ISO 4126-1:2013/Amd 1:2016, *Safety devices for protection against excessive pressure — Part 1: Safety valves*

ISO 4126-2:2018, *Safety devices for protection against excessive pressure — Part 2: Bursting disc safety devices*

ISO 21922:2021, *Refrigerating systems and heat pumps — Valves — Requirements, testing and marking*

EN 13501-1:2018, *Fire classification of construction products and building elements — Part 1: Classification using data from reaction to fire tests*

3 Terms and definitions

For the purposes of this document, the terms and definitions given in ISO 21922:2021, ISO 4126-1:2013/Amd 1:2016, and ISO 4126-2:2018 and the following apply.

ISO and IEC maintain terminology databases for use in standardization at the following addresses:

- ISO Online browsing platform: available at <https://www.iso.org/obp>
- IEC Electropedia: available at <https://www.electropedia.org/>

3.1

refrigerant

fluid used for heat transfer in a refrigerating system

Note 1 to entry: A refrigerant absorbs heat at a low temperature and a low pressure of the fluid and rejects it at a higher temperature and a higher pressure of the fluid, usually involving changes of the phase of the fluid.

[SOURCE: ISO 817:2024, 3.1.37]

3.2

part of the refrigerating system

several components assembled together and exposed to the same pressure in operation or pressure source, respectively, as determined by the manufacturer

3.3

pressure relief device

pressure relief valve or bursting disc device designed to relieve excessive pressure automatically

3.4

pressure relief valve

pressure actuated valve held shut by a spring or other means and designed to relieve excessive pressure automatically by starting to open at a set pressure and re-closing after the pressure has fallen below the set pressure

Note 1 to entry: For the purposes of this document, the definition of a safety valve as given in ISO 4126-1:2013 is regarded equivalent to a pressure relief valve.

3.5

pressure vessel

any refrigerant-containing component of a refrigerating system other than:

- coils (including their headers) consisting of pipes with air as secondary fluid;
- piping and its valves, joints and fittings;
- control devices;
- pressure switches, gauges, liquid indicators;
- safety valves, fusible plugs, bursting discs;
- equipment comprising casings or machinery where the dimensioning, choice of material and manufacturing rules are based primarily on requirements for sufficient strength, rigidity and stability to meet the static and dynamic operational effects or other operational characteristics and for which pressure is not a significant design factor. Such equipment may include: pumps and compressors.

Note 1 to entry: The semi-hermetic and open type compressors used in refrigerating systems may be subject to the exclusion article 1.2.j of the EU Directive 2014/68/EU by referring to the working party group guidelines WPG A-11, A-12 and B-34. The compressor manufacturer has to decide on the basis of a case by case assessment, if the exclusion article 1.2.j of the EU Directive 2014/68/EU is applicable.

Note 2 to entry: This definition is aligned to EU Directive 2014/68/EU.

3.6

nominal size

DN

alphanumeric designation of size for components of a pipework system, which is used for reference purposes comprising the letters *DN* followed by a dimensionless whole number which is indirectly related to the physical size, in millimetres, of the bore or outside diameter of the end connections

Note 1 to entry: The number following the letters *DN* does not represent a measurable value and should not be used for calculation purposes except where specified in this document.

Note 2 to entry: Where the nominal size is not specified, for the purpose of this document it is assumed to be the internal diameter of the pipe or component in mm (*DN/ID*).

Note 3 to entry: Nominal size is not the same as port size which is commonly used for the size of the valve seat opening.

[SOURCE: ISO 6708:1995, 2.1, modified — Note 2 and 3 to entry added.]

4 Symbols

Symbol	Designation	Unit
A_{actual}	Actual flow area of the pressure relief device. The flow area at the most narrow cross section when the pressure relief device is fully open	mm ²
$A_{\text{effective}}$	Effective area of the pressure relief device	mm ²
A_{liq}	Calculated flow area of liquid after expansion	mm ²
A_{R}	Inside area of tube	mm ²
A_{surf}	External surface area of the vessel	m ²
A_{vap}	Calculated flow area of vapour after expansion	mm ²
DN	Nominal size	–
d	Actual most narrow flow diameter of the pressure relief device	mm
d_{R}	Inside diameter of tube	mm
f	Darcy friction factor	–
Δh_{vap}	Heat of vaporisation	kJ/kg
K_{cap}	Capacity correction factor	–
K_{d}	Certified coefficient of discharge considering the backpressure ratio p_{b}/p_0 and the possible reduced stroke of the pressure relief valve	–
K_{dr}	De-rated coefficient of discharge	–
K_{drl}	De-rated coefficient of discharge for liquid	–
K_{vs}	Valve constant (the rate of water flow for a pressure loss of 1 bar at the rated full opening)	m ³ /h
K_{visc}	Viscosity correction factor	–
K_{volume}	Trapped liquid factor	mm ² /l
L	Length of pipe	mm
m	mass	kg
n	Rotational frequency	min ⁻¹
p_{atm}	Atmospheric pressure (1,013 25 bar)	bar
p_{b}	Back pressure at outlet of pressure relief device, absolute	bar
p_{c}	Critical absolute pressure	bar
$p_{\text{connection}}$	Pressure in connection point	bar
$p_{\text{r,choked}}$	Choked pressure ratio	–
p_{set}	Set pressure, gauge (the pre-determined pressure at which a pressure relief device under operation starts to open)	bar
Δp	Pressure loss	bar
Δp_{common}	Pressure loss in common outlet line	bar
Δp_{in}	Pressure loss in the inlet line to the pressure relief device	bar
Δp_{out}	Pressure loss in the outlet line from the pressure relief device	bar
p_0	Actual absolute relieving pressure	bar
p_1	Absolute pressure at the inlet to the outlet line of the pressure relief device	bar
Q_{h}	Rate of heat production, internal heat source	kW
$Q_{\text{m,adjusted}}$	Adjusted discharge capacity, of the pressure relief device. Used for pressure drop calculation in piping	kg/h
$Q_{\text{m,common}}$	Mass flow in common outlet line	kg/h
$Q_{\text{m,liq}}$	Flow of liquid after expansion	kg/h
$Q_{\text{m,relief}}$	Calculated refrigerant mass flow rate of the pressure relief device	kg/h
$Q_{\text{m,required}}$	Minimum required discharge capacity, of refrigerant, of the pressure relief device	kg/h

NOTE 1 bar = 0,1 MPa = 10⁵ Pa; 1 MPa = 1 N/mm².

Symbol	Designation	Unit
$Q_{m,vap}$	Flow of vapour after expansion	kg/h
q_m	Theoretical discharge capacity	kg/h·mm ²
q'_m	Actual discharge capacity determined by tests	kg/h·mm ²
R	Bending radius of bend	mm
Re	Reynolds number	–
s	Thickness of insulation	m
u	Velocity in line	m/s
V	Theoretical displacement (volume)	m ³
v	Specific volume of vapour or liquid	m ³ /kg
v_0	Specific volume of vapour in inlet line	m ³ /kg
v_1	Specific volume at the inlet to the outlet line of the pressure relief device	m ³ /kg
w_0	Actual flow speed of liquid in the smallest section of pressure relief valve	m/s
w_1	Speed at the inlet into the outlet line	m/s
x	Vapour fraction of refrigerant at p_b	–
α	Flush connection angle	°
γ	Heat capacity ratio	–
ε_R	Pipe roughness	mm
ζ	Pressure loss coefficient	–
ζ_{DN}	Pressure loss coefficient related to DN	–
$\zeta_{fittings}$	Pressure loss coefficient of fittings	–
ζ_{pipes}	Pressure loss coefficient of pipes in outlet line	–
ζ_{total}	Total pressure loss coefficient in outlet line	–
η_v	Volumetric efficiency estimated at suction pressure and discharge pressure equivalent to the pressure relief device setting	–
ν	Kinematic viscosity	m ² /s
ρ	Density of vapour or liquid	kg/m ³
ρ_0	Density of vapour in inlet line	kg/m ³
ρ_{10}	Vapour density at refrigerant saturation pressure/dew point at 10 °C	kg/m ³
ϕ	Density of heat flow rate	kW/m ²
ϕ_{red}	Reduced density of heat flow rate	kW/m ²
NOTE 1 bar = 0,1 MPa = 10 ⁵ Pa; 1 MPa = 1 N/mm ² .		

5 General

This document describes the calculation of:

- The required discharge capacity of a pressure relief device.
- The actual capacity of a pressure relief device.
- Pressure losses in inlet and outlet lines from the pressure relief device.

The capacity of the pressure relief device (calculated in [Clause 7](#)), shall be larger than the required capacity (calculated in [Clause 6](#)), and the pressure losses (calculated in [Clause 8](#)) shall be within given limits for the pressure relief device to operate correctly.

The Formulae in [Clause 7](#) are only valid for discharge of refrigerant gas or vapour.

NOTE 1 Calculations of flow areas for pressure relief devices for non-flashing and flashing liquids are given in [Annex B](#). Example calculations with corresponding piping are given in [Annex C](#).

ISO 24664:2024(en)

NOTE 2 Requirements for protection against excessive pressure in refrigerating systems and heat pumps are given in EN 378-2 and ISO 5149-2.

For design and manufacturing of bodies, bonnets and bolts for pressure relief devices (safety valves and bursting discs) and for the specification of strength pressure test, ISO 21922:2021 applies.

For other aspects, the requirements of ISO 4126-1:2013/Amd 1:2016, Clause 5, Clause 7, and Clause 10, and ISO 4126-2:2018, Clause 17, apply.

The actual absolute relieving pressure of a pressure relief device is calculated as:

$$p_0 = 1,1 \cdot p_{\text{set}} + p_{\text{atm}} \quad (1)$$

For calculation of the required discharge capacity of a pressure relief device, knowledge of the heat of vaporisation Δh_{vap} of the refrigerant is required.

For calculation of the actual discharge capacity of a pressure relief device, knowledge of the density ρ_0 (or specific volume v_0) and the heat capacity ratio γ of the refrigerant is required.

For calculation of pressure losses in inlet and outlet lines, knowledge of the density ρ_0 (or specific volume v_0) is required.

The values are found at the following conditions:

- a) If the pressure p_0 is less than the critical pressure of the refrigerant:
 - If the saturated gas temperature corresponding to p_0 is higher than the critical temperature minus 5 K, then ρ_0 , v_0 and Δh_{vap} are found at saturated gas at critical temperature minus 5 K.
 - Else ρ_0 , v_0 and Δh_{vap} are found at saturated gas at pressure p_0 . If the inlet temperature is given (superheated gas), then ρ_0 , v_0 and Δh_{vap} are found at pressure p_0 and the inlet temperature.
- b) If the pressure p_0 is higher than the critical pressure of the refrigerant, then ρ_0 , v_0 and Δh_{vap} are found at saturated gas at critical temperature minus 5 K.

The value of the heat capacity ratio γ shall be found at 25 °C and 1,013 25 bar. Values of γ for different refrigerants can be found in [Table A.1](#).

To check if the velocity in the outlet line is larger than the speed of sound, the density and the speed of sound of the refrigerant at the outlet of the outlet line are needed. The refrigerant properties at the outlet of the outlet line are found assuming isenthalpic expansion from the relieving condition (p_0 , v_0) to the pressure at the outlet of the outlet line. If the isenthalpic expansion results in either a mixture of gas and liquid or a mixture of gas and solid, then the density and speed of sound of saturated gas at the pressure at the outlet of the outlet line are used.

6 Minimum required discharge capacity for protection of parts of a refrigerating system

6.1 General

Calculations are based on known or assumed processes, which result in an increase in pressure. All foreseeable processes shall be considered. The commonly relevant processes are covered in [6.2](#), [6.3](#) and [6.4](#).

NOTE Information about necessary protection measures against excessive pressure can be found in system safety standards such as ISO 5149-2 and EN 378-2. For instance due to standstill pressure, pressure to internal or external heat sources, or trapped fluid.

In case of supercritical pressure, the pressure relief valve shall be suitable for both gas and liquid.

In case of relieving CO₂ to a pressure below the triple point (e.g. atmospheric pressure), there is a possibility to create solid CO₂. Necessary precautions shall be taken to ensure safe operation.

Even if a vessel contains only gas, it might in some situations contain liquid and should therefore for the purpose of this document be treated as a vessel containing both liquid and gas.

6.2 Excessive pressure caused by heat sources

6.2.1 External heat sources

The minimum required discharge capacity of the pressure relief device for pressure vessels is calculated as in [Formula \(2\)](#):

$$Q_{m,required} = \frac{3\,600 \cdot \phi \cdot A_{surf}}{\Delta h_{vap}} \quad (2)$$

For pressure vessels in this document, the density of heat flow rate ϕ is assumed to be 10 kW/m², but a higher value shall be used if necessary.

When the thickness, s , of the insulation of the pressure vessel is higher than 0,04 m and the insulation is tested for reaction to fire according to EN 13501-1:2018 and classified better than class C, a reduced density of heat flow rate shall be used as a minimum value:

$$\phi_{red} = \phi \cdot \frac{0,04}{s} \quad (3)$$

For pressure vessels the total external surface area of the vessel is calculated depending on geometry.

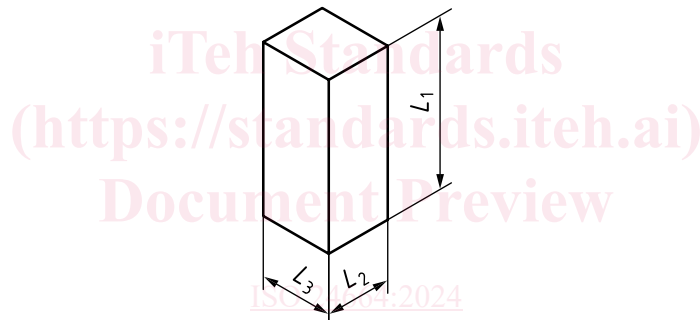

Figure 1 — Plate heat exchanger (PHE)

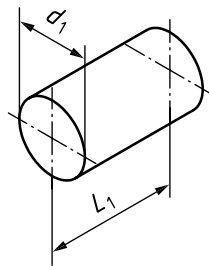

Figure 2 — Plate and shell heat exchanger (PSHE)