**Vacuum technology — Dimensions of
clamped-type quick-release couplings**

Technique du vide — Dimensions des raccords rapides à colliers

iTeh Standards
(<https://standards.iteh.ai>)
Document Preview

[ISO 2861:2020](#)

<https://standards.iteh.ai/catalog/standards/iso/120ce4bf-c68e-4f7d-b849-63c7781f74ce/iso-2861-2020>



iTeh Standards
(<https://standards.iteh.ai>)
Document Preview

[ISO 2861:2020](https://standards.iteh.ai/catalog/standards/iso/120ce4bf-c68e-4f7d-b849-63c7781f74ce/iso-2861-2020)

<https://standards.iteh.ai/catalog/standards/iso/120ce4bf-c68e-4f7d-b849-63c7781f74ce/iso-2861-2020>



COPYRIGHT PROTECTED DOCUMENT

© ISO 2020

All rights reserved. Unless otherwise specified, or required in the context of its implementation, no part of this publication may be reproduced or utilized otherwise in any form or by any means, electronic or mechanical, including photocopying, or posting on the internet or an intranet, without prior written permission. Permission can be requested from either ISO at the address below or ISO's member body in the country of the requester.

ISO copyright office
CP 401 • Ch. de Blandonnet 8
CH-1214 Vernier, Geneva
Phone: +41 22 749 01 11
Fax: +41 22 749 09 47
Email: copyright@iso.org
Website: www.iso.org

Published in Switzerland

Contents

	Page
Foreword	iv
1 Scope	1
2 Normative references	1
3 Terms and definitions	1
4 Symbols	2
5 Requirements	3
5.1 Coupling	3
5.2 O-ring	4
5.3 O-ring carrier	5
5.4 Clamp	5
Bibliography	6

iTeh Standards
 (https://standards.iteh.ai)
 Document Preview

[ISO 2861:2020](https://standards.iteh.ai/catalog/standards/iso/120ce4bf-c68e-4f7d-b849-63c7781f74ce/iso-2861-2020)

<https://standards.iteh.ai/catalog/standards/iso/120ce4bf-c68e-4f7d-b849-63c7781f74ce/iso-2861-2020>

Foreword

ISO (the International Organization for Standardization) is a worldwide federation of national standards bodies (ISO member bodies). The work of preparing International Standards is normally carried out through ISO technical committees. Each member body interested in a subject for which a technical committee has been established has the right to be represented on that committee. International organizations, governmental and non-governmental, in liaison with ISO, also take part in the work. ISO collaborates closely with the International Electrotechnical Commission (IEC) on all matters of electrotechnical standardization.

The procedures used to develop this document and those intended for its further maintenance are described in the ISO/IEC Directives, Part 1. In particular, the different approval criteria needed for the different types of ISO documents should be noted. This document was drafted in accordance with the editorial rules of the ISO/IEC Directives, Part 2 (see www.iso.org/directives).

Attention is drawn to the possibility that some of the elements of this document may be the subject of patent rights. ISO shall not be held responsible for identifying any or all such patent rights. Details of any patent rights identified during the development of the document will be in the Introduction and/or on the ISO list of patent declarations received (see www.iso.org/patents).

Any trade name used in this document is information given for the convenience of users and does not constitute an endorsement.

For an explanation of the voluntary nature of standards, the meaning of ISO specific terms and expressions related to conformity assessment, as well as information about ISO's adherence to the World Trade Organization (WTO) principles in the Technical Barriers to Trade (TBT), see www.iso.org/iso/foreword.html.

This document was prepared by Technical Committee ISO/TC 112, *Vacuum technology*.

This second edition cancels and replaces the first edition (ISO 2861:2013), of which it constitutes a minor revision. The changes compared to the previous edition are as follows:

- “ d_1 ” in [Table 3](#) has been corrected to “ d_4 ”;
- the Bibliography has been updated.

Any feedback or questions on this document should be directed to the user's national standards body. A complete listing of these bodies can be found at www.iso.org/members.html.

Vacuum technology — Dimensions of clamped-type quick-release couplings

1 Scope

This document specifies the dimensions of the clamped-type quick-release couplings used in vacuum technology, as well as those of the O-rings and their carriers associated with these couplings, used to ensure vacuum tightness.

NOTE The dimensions retained for the coupling diameter ensure the compatibility of the quick-release coupling with the corresponding vacuum flanges specified in ISO 1609^[1].

2 Normative references

There are no normative references in this document.

3 Terms and definitions

For the purposes of this document, the following terms and definitions apply.

ISO and IEC maintain terminological databases for use in standardization at the following addresses:

- ISO Online browsing platform: available at <https://www.iso.org/obp>
- IEC Electropedia: available at <http://www.electropedia.org/>

3.1

clamped-type quick-release coupling ISO 2861:2020

connection which may be joined or separated without the use of tools 63c7781f74ce/iso-2861-2020

Note 1 to entry: It ensures vacuum tightness associated with the O-rings and their carriers.

Note 2 to entry: The types and dimensions of clamps to tight couplings are not specified in document.

Note 3 to entry: See [Figure 1](#).

[SOURCE: ISO 14617-3:2002, 3.15, modified — "clamped-type" has been added to the term; Notes 1 to 3 are additional to the original definition.]

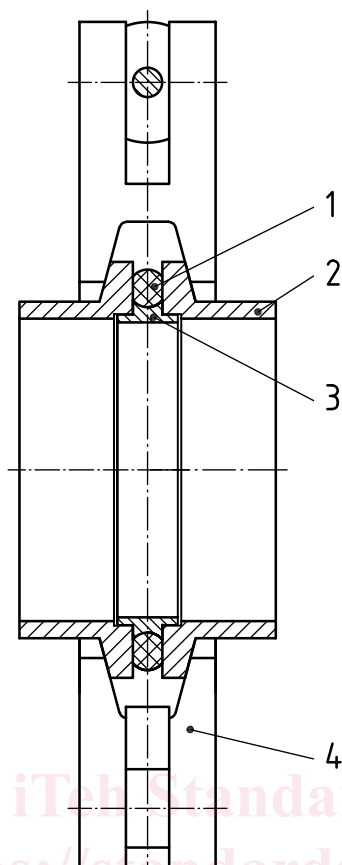

Key

- 1 O-ring
- 2 coupling
- 3 O-ring carrier
- 4 clamp

iTech Standards
 (https://standards.itih.ai)
 Document Preview

ISO 2861:2020

<https://standards.itih.ai/catalog/standards/iso/120ce4bf-c68e-4f7d-b849-63c7781f74ce/iso-2861-2020>

Figure 1 — Quick-release coupling with typical clamp

4 Symbols

Symbol	Description	Unit
D	Inside diameter of O-ring	mm
d_1	Outside diameter of connecting pipe	mm
d_2	Diameter of O-ring carrier retainer	mm
d_3	Outside diameter of coupling	mm
d_4	Inside diameter of O-ring carrier	mm
d_5	Outside diameter connecting pipe of O-ring carrier	mm
d_6	Outside diameter to hold O-ring in O-ring carrier	mm
R	Radius of O-ring retainer in O-ring carrier	mm