

---

---

## Vacuum technology — Dimensions of knife-edge flanges

*Technique du vide — Dimensions des brides à guillotine*

**iTeh STANDARD PREVIEW**  
(standards.iteh.ai)

Full standard:  
<https://standards.iteh.ai/catalog/standards/sist/02727f16-c080-4811-8a11-c40453bd9e38/iso-3669-2020>



**iTeh STANDARD PREVIEW**  
(standards.iteh.ai)  
Full standard:  
<https://standards.iteh.ai/catalog/standards/sist/02727f16-c080-4811-8a11-c40453bd9e38/iso-3669-2020>



**COPYRIGHT PROTECTED DOCUMENT**

© ISO 2020

All rights reserved. Unless otherwise specified, or required in the context of its implementation, no part of this publication may be reproduced or utilized otherwise in any form or by any means, electronic or mechanical, including photocopying, or posting on the internet or an intranet, without prior written permission. Permission can be requested from either ISO at the address below or ISO's member body in the country of the requester.

ISO copyright office  
CP 401 • Ch. de Blandonnet 8  
CH-1214 Vernier, Geneva  
Phone: +41 22 749 01 11  
Fax: +41 22 749 09 47  
Email: [copyright@iso.org](mailto:copyright@iso.org)  
Website: [www.iso.org](http://www.iso.org)

Published in Switzerland

# Contents

	Page
Foreword.....	iv
Introduction.....	v
<b>1 Scope.....</b>	<b>1</b>
<b>2 Normative references.....</b>	<b>1</b>
<b>3 Terms and definitions.....</b>	<b>1</b>
<b>4 Symbols and abbreviated terms.....</b>	<b>1</b>
<b>5 Requirements.....</b>	<b>2</b>
5.1 Materials.....	2
5.1.1 Flange.....	2
5.1.2 Bolt holes.....	2
5.1.3 Grooves.....	2
5.1.4 Gasket.....	2
5.2 Dimensions.....	2
<b>Bibliography.....</b>	<b>7</b>

**iTeh STANDARD PREVIEW**  
 (standards.iteh.ai)

Full standard:  
<https://standards.iteh.ai/catalog/standards/sist/02727f16-c080-4811-8a11-c40453bd9e38/iso-3669-2020>

## Foreword

ISO (the International Organization for Standardization) is a worldwide federation of national standards bodies (ISO member bodies). The work of preparing International Standards is normally carried out through ISO technical committees. Each member body interested in a subject for which a technical committee has been established has the right to be represented on that committee. International organizations, governmental and non-governmental, in liaison with ISO, also take part in the work. ISO collaborates closely with the International Electrotechnical Commission (IEC) on all matters of electrotechnical standardization.

The procedures used to develop this document and those intended for its further maintenance are described in the ISO/IEC Directives, Part 1. In particular, the different approval criteria needed for the different types of ISO documents should be noted. This document was drafted in accordance with the editorial rules of the ISO/IEC Directives, Part 2 (see [www.iso.org/directives](http://www.iso.org/directives)).

Attention is drawn to the possibility that some of the elements of this document may be the subject of patent rights. ISO shall not be held responsible for identifying any or all such patent rights. Details of any patent rights identified during the development of the document will be in the Introduction and/or on the ISO list of patent declarations received (see [www.iso.org/patents](http://www.iso.org/patents)).

Any trade name used in this document is information given for the convenience of users and does not constitute an endorsement.

For an explanation of the voluntary nature of standards, the meaning of ISO specific terms and expressions related to conformity assessment, as well as information about ISO's adherence to the World Trade Organization (WTO) principles in the Technical Barriers to Trade (TBT), see [www.iso.org/iso/foreword.html](http://www.iso.org/iso/foreword.html).

This document was prepared by Technical Committee ISO/TC 112, *Vacuum technology*.

This third edition cancels and replaces the second edition (ISO 3669:2017), of which it constitutes a minor revision. The changes compared to the previous edition are as follows:

- the title has been updated;
- [Clause 4](#) and [Table 1](#): “ $l_7$ ” has changed to “ $l_7$  – Depth for pipe connection”;
- Reference [\[4\]](#) has been updated.

Any feedback or questions on this document should be directed to the user's national standards body. A complete listing of these bodies can be found at [www.iso.org/members.html](http://www.iso.org/members.html).

## Introduction

This document is a minor revision of the second edition (ISO 3669:2017) and contains significant technical changes from the first edition (ISO 3669:1986), which defined two series of “bakeable” flanges:

- as a preferred series, the main dimensions of which ensure compatibility with already standardized non-bakeable flanges (see ISO 1609);
- a secondary series corresponding to flanges in common use.

This document specifies only one series and is no longer dependent on the preferred number. Effectively, the preferred series has been made obsolete, thereby promoting the secondary series to be the one and only set of specified dimensions. Furthermore, several dimensions in what was formerly the secondary series, have been modified to correspond to flanges in common use. Finally, detailed dimensions for the knife-edge sealing profile have been incorporated.

It is noted, however, that the original ConFlat®<sup>1)</sup> flange dimensions and tolerances, as developed by Varian, were not available during the development stage of this specification. The intent of this document is to ensure interchangeability of flanges. It is reasonable to accept that flanges manufactured to the original Varian specifications are compatible with flanges manufactured according to this document, even though they might not fall within all tolerances.

**PREVIEW**  
iTeh STANDARD PREVIEW  
(standards.iteh.ai)  
Full standard:  
<https://standards.iteh.ai/catalog/standards/sist/02727f16-c080-4811-8a11-c40453bd9e38/iso-3669-2020>

---

1) ConFlat® is the trademark of a product supplied by Varian, Inc. This information is given for the convenience of users of this document and does not constitute an endorsement by ISO of the product named. Equivalent products may be used if they can be shown to lead to the same results.

**iTeh STANDARD PREVIEW**  
**(standards.iteh.ai)**

Full standard:  
<https://standards.iteh.ai/catalog/standards/sist/02727f16-c080-4811-8a11-c40453bd9e38/iso-3669-2020>

# Vacuum technology — Dimensions of knife-edge flanges

## 1 Scope

This document specifies the dimensions of fixed or rotatable bolted knife-edge flanges used in vacuum systems for pressures ranging from atmospheric to as low as  $10^{-11}$  Pa.

## 2 Normative references

There are no normative references in this document.

## 3 Terms and definitions

For the purposes of this document, the following terms and definitions apply.

ISO and IEC maintain terminological databases for use in standardization at the following addresses:

- ISO Online browsing platform: available at <http://www.iso.org/obp>
- IEC Electropedia: available at <http://www.electropedia.org/>

### 3.1

#### knife-edge flange

metal sealed flange used for high and ultra-high vacuum service

Note 1 to entry: Sandwiching one metal gasket between two knife-edge flanges and securely bolting these together makes a vacuum tight joint. The seal is made when the identical circular (triangular profile) knife-edges are bolted together. A deformable metal gasket captured between the knife-edge flanges establishes the sealing surface.

Note 2 to entry: Originally developed as ConFlat® flanges. The widespread and continued use of knife-edge flanges has made these a de facto international standard, codified by this document.

### 3.2

#### nominal bore

value intended to both identify the flange and specify the largest practical size of tubing that can be accommodated by the flange

Note 1 to entry: See [Table 1](#), in which the convention of identifying original flanges by the outside diameter of the flange (historically in inches) has been maintained.

### 3.3

#### leak check groove

groove machined into the seal side of the flange to facilitate the free passage of trace gas from the outer perimeter of the flange to the seal zone near the metal gasket

## 4 Symbols and abbreviated terms

Symbol	Designation	Unit
$l_1$	nominal outside diameter of flange	mm (in)
$l_2$	max. tube	mm
$l_3$	bolt hole	mm
$l_4$	bolt circle	mm

Symbol	Designation	Unit
$\phi$	position tolerance of bolt hole centre	mm
$l_5$	seal recess	mm
$l_6$	knife-edge	mm
$l_7$	depth for pipe connection	mm
$l_8$	setback for inner rotatable ring	mm
$l_9$	flange thickness	mm
$l_{10}$	outside diameter of metal gasket	mm

## 5 Requirements

### 5.1 Materials

#### 5.1.1 Flange

The selection of the material shall be compatible with the requirements for the flanges. Considerations may include service temperature, sealing capacity, corrosion resistance, magnetic permeability, type of seal gasket used and dimensions.

NOTE Austenitic stainless steel is commonly used, but it is not the intent of this document to specify or limit the choice of flange material to austenitic stainless steel.

#### 5.1.2 Bolt holes

The flange may have either clearance or tapped bolt holes.

NOTE As a number of flanges in use currently originated in the United States, the tapped flanges often have English tapped holes. Of increasing use are flanges with metric threads. Both are presented in this document (see [Table 1](#)).

#### 5.1.3 Grooves

Leak check grooves should be used. The grooves shall be arranged equidistantly between the bolt holes.

#### 5.1.4 Gasket

In general, the gasket should be softer than the flange to avoid dulling of flange knife-edge.

NOTE Oxygen-free high conductivity (OFHC) copper is commonly used, but it is not the intent of this document to specify or limit the choice of gasket material to OFHC copper.

### 5.2 Dimensions

Flange dimensions are shown and specified in [Figures 1 to 3](#) and in [Table 1](#) and [Table 2](#). See [Figure 4](#) for the recommended dimensions of leak check grooves.



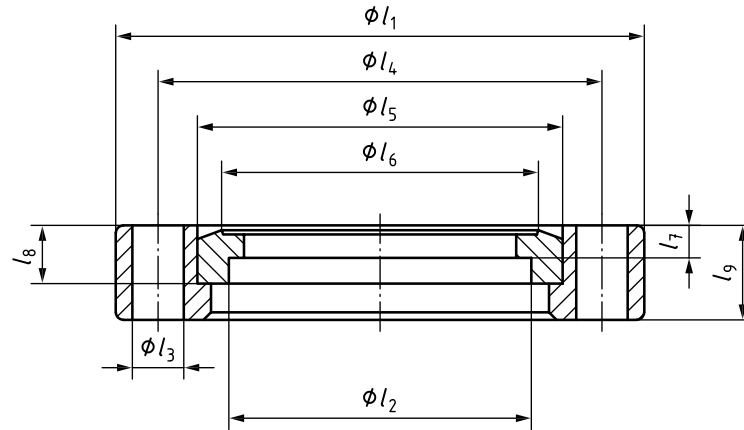

a) Rotatable flange

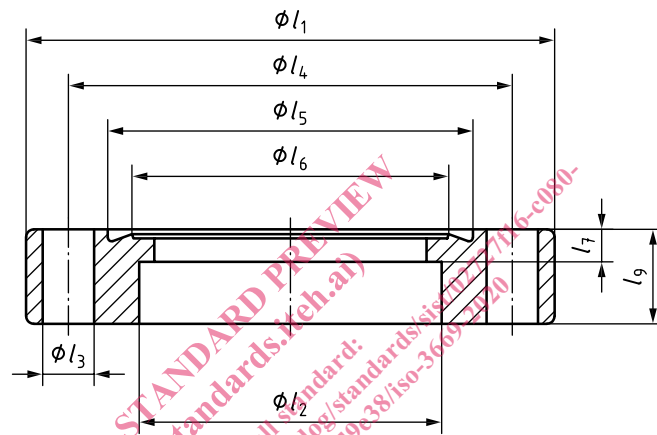

b) Non-rotatable flange

Figure 1 — Basic flange dimensions

Dimensions in millimetres

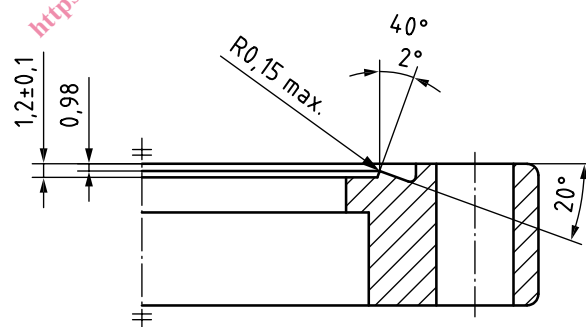

Figure 2 — Knife-edge detail

Dimensions in millimetres

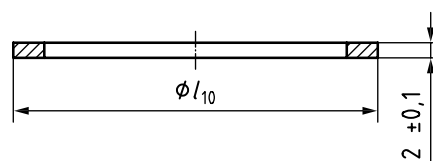

Figure 3 — Metal gasket