

---

---

**Pliers and nippers — Slip joint pliers  
— Dimensions and test values**

*Pinces et tenailles — Pinces réglables à deux positions — Dimensions  
et valeurs d'essai*

**iTeh STANDARD PREVIEW**  
**(standards.iteh.ai)**

[ISO 9343:2021](https://standards.iteh.ai/catalog/standards/sist/e759668b-4fcd-40b7-8127-3f07649e3bfb/iso-9343-2021)

[https://standards.iteh.ai/catalog/standards/sist/e759668b-4fcd-40b7-8127-  
3f07649e3bfb/iso-9343-2021](https://standards.iteh.ai/catalog/standards/sist/e759668b-4fcd-40b7-8127-3f07649e3bfb/iso-9343-2021)



## iTeh STANDARD PREVIEW (standards.iteh.ai)

ISO 9343:2021

<https://standards.iteh.ai/catalog/standards/sist/e759668b-4fcd-40b7-8127-3f07649e3bfb/iso-9343-2021>



### **COPYRIGHT PROTECTED DOCUMENT**

© ISO 2021

All rights reserved. Unless otherwise specified, or required in the context of its implementation, no part of this publication may be reproduced or utilized otherwise in any form or by any means, electronic or mechanical, including photocopying, or posting on the internet or an intranet, without prior written permission. Permission can be requested from either ISO at the address below or ISO's member body in the country of the requester.

ISO copyright office  
CP 401 • Ch. de Blandonnet 8  
CH-1214 Vernier, Geneva  
Phone: +41 22 749 01 11  
Email: [copyright@iso.org](mailto:copyright@iso.org)  
Website: [www.iso.org](http://www.iso.org)

Published in Switzerland

# Contents

	Page
Foreword.....	iv
<b>1 Scope.....</b>	<b>1</b>
<b>2 Normative references.....</b>	<b>1</b>
<b>3 Terms and definitions.....</b>	<b>1</b>
<b>4 Dimensions and test value.....</b>	<b>1</b>
<b>5 Designation.....</b>	<b>2</b>
<b>6 Marking.....</b>	<b>2</b>

## iTeh STANDARD PREVIEW (standards.iteh.ai)

[ISO 9343:2021](https://standards.iteh.ai/catalog/standards/sist/e759668b-4fcd-40b7-8127-3f07649e3bfb/iso-9343-2021)

<https://standards.iteh.ai/catalog/standards/sist/e759668b-4fcd-40b7-8127-3f07649e3bfb/iso-9343-2021>

## Foreword

ISO (the International Organization for Standardization) is a worldwide federation of national standards bodies (ISO member bodies). The work of preparing International Standards is normally carried out through ISO technical committees. Each member body interested in a subject for which a technical committee has been established has the right to be represented on that committee. International organizations, governmental and non-governmental, in liaison with ISO, also take part in the work. ISO collaborates closely with the International Electrotechnical Commission (IEC) on all matters of electrotechnical standardization.

The procedures used to develop this document and those intended for its further maintenance are described in the ISO/IEC Directives, Part 1. In particular, the different approval criteria needed for the different types of ISO documents should be noted. This document was drafted in accordance with the editorial rules of the ISO/IEC Directives, Part 2 (see [www.iso.org/directives](http://www.iso.org/directives)).

Attention is drawn to the possibility that some of the elements of this document may be the subject of patent rights. ISO shall not be held responsible for identifying any or all such patent rights. Details of any patent rights identified during the development of the document will be in the Introduction and/or on the ISO list of patent declarations received (see [www.iso.org/patents](http://www.iso.org/patents)).

Any trade name used in this document is information given for the convenience of users and does not constitute an endorsement.

For an explanation of the voluntary nature of standards, the meaning of ISO specific terms and expressions related to conformity assessment, as well as information about ISO's adherence to the World Trade Organization (WTO) principles in the Technical Barriers to Trade (TBT), see [www.iso.org/iso/foreword.html](http://www.iso.org/iso/foreword.html).

This document was prepared by Technical Committee ISO/TC 29, *Small tools*, Subcommittee SC 10, *Assembly tools for screws and nuts, pliers and nippers*.

This third edition cancels and replaces the second edition (ISO 9343:2004), which has been technically revised.

The main changes compared to the previous edition are as follows:

- introduced minimum and maximum lengths for each nominal length.

Any feedback or questions on this document should be directed to the user's national standards body. A complete listing of these bodies can be found at [www.iso.org/members.html](http://www.iso.org/members.html).

# Pliers and nippers — Slip joint pliers — Dimensions and test values

## 1 Scope

This document specifies the principal dimensions of slip joint pliers, designated as No. 206 in ISO 5742, and the test values, in order to verify their aptitude to function in conformity with ISO 5744. The general technical requirements are given in ISO 5743.

The slip joint pliers illustrated in this document are examples only and are not intended to affect the manufacturer's design.

## 2 Normative references

The following documents are referred to in the text in such a way that some or all of their content constitutes requirements of this document. For dated references, only the edition cited applies. For undated references, the latest edition of the referenced document (including any amendments) applies.

ISO 5742, *Pliers and nippers — Nomenclature*

ISO 5743, *Pliers and nippers — General technical requirements*

ISO 5744:2004, *Pliers and nippers — Methods of test*

## 3 Terms and definitions

For the purposes of this document, the terms and definitions given in ISO 5742 apply.

ISO and IEC maintain terminology databases for use in standardization at the following addresses:

- ISO Online browsing platform: available at <https://www.iso.org/obp>
- IEC Electropedia: available at <https://www.electropedia.org/>

## 4 Dimensions and test value

The principal dimensions of slip joint pliers are shown in [Figure 1](#) and given in [Table 1](#).

For the pliers provided with a comfort grip, the opening of the handle shall be defined with the comfort grip.

After the load test, the permanent set,  $s$ , shall not exceed the value given in [Table 1](#). If distance  $l_1$  is not suitable for the load test, the formula given in ISO 5744:2004, 4.2 shall be used.

$w_1$  shall be measured with the slip joint in the minimum jaw opening position.

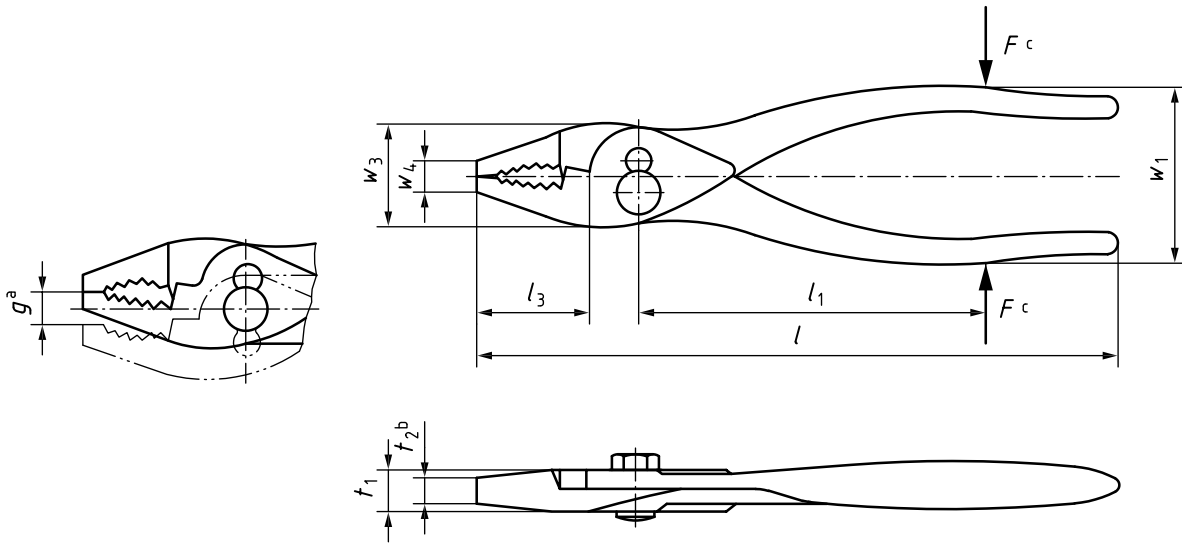

- a Jaws parallel.
- b  $t_2 \leq t_1$ .
- c  $F$  = load applied in load test.

**Figure 1 — Slip joint pliers**  
iTeh STANDARD PREVIEW  
(standards.iteh.ai)

**Table 1 — Slip joint pliers, principal dimensions and load test values**

$l$	Length		$w_1$ $\pm 15$ mm	$w_3$ max. mm	$w_4$ max. mm	$t_1$ max. mm	$l_1$ mm	$l_3$ $\pm 5$ mm	$g$ min. mm	Load test	
	$l_{min}$ mm	$l_{max}$ mm								Load $F$ N	Maximum permanent set $s^a$ max. mm
160	150	169	48	32	8	10	80	30	7	1 000	1,12
180	170	189	49	35	10	11	90	35	8	1 120	1,25
200	190	229	50	40	12,5	12,5	100	35	9	1 250	1,4
250	230	269	50	45	12,5	12,5	125	40	10	1 400	1,8

<sup>a</sup>  $s = w_1 - w_2$  (see ISO 5744).

## 5 Designation

EXAMPLE

Slip joint pliers, number 206 in accordance with ISO 5742, with a nominal length  $l = 180$  are designated as follows:

**Slip joint pliers 206 - ISO 9343 - 180**

## 6 Marking

Marking shall be in accordance with ISO 5743.

**iTeh STANDARD PREVIEW**  
**(standards.iteh.ai)**

ISO 9343:2021

<https://standards.iteh.ai/catalog/standards/sist/e759668b-4fcd-40b7-8127-3f07649e3bfb/iso-9343-2021>