



SLOVENSKI STANDARD
SIST EN 300 175-8 V1.5.1:2005

01-julij-2005

8 [[]HJbY]nVc`ýUbYVfYnj fj] bYhY_Y_ca i b]_UWYfB 97 HŁ! 'G_i db]j a Ygb]_ 'f7 Ł!', "
XY. '?cX]fUbY]b'dfYbcg[cj cfU

Digital Enhanced Cordless Telecommunications (DECT); Common Interface (CI); Part 8:
Speech coding and transmission

iTeh STANDARD PREVIEW
(standards.iteh.ai)

[SIST EN 300 175-8 V1.5.1:2005](https://standards.iteh.ai/catalog/standards/sist/a9cf2d90-a6a3-48fc-811b-1e879bde4548/sist-en-300-175-8-v1-5-1-2005)

[https://standards.iteh.ai/catalog/standards/sist/a9cf2d90-a6a3-48fc-811b-](https://standards.iteh.ai/catalog/standards/sist/a9cf2d90-a6a3-48fc-811b-1e879bde4548/sist-en-300-175-8-v1-5-1-2005)

[1e879bde4548/sist-en-300-175-8-v1-5-1-2005](https://standards.iteh.ai/catalog/standards/sist/a9cf2d90-a6a3-48fc-811b-1e879bde4548/sist-en-300-175-8-v1-5-1-2005)

Ta slovenski standard je istoveten z: EN 300 175-8 Version 1.5.1

ICS:

33.070.30 Öã äæ) ^/ã à[|bzæ ^ Digital Enhanced Cordless
à!^: ç!çã } ^/ã ^\ [{ ~ } ä æã Telecommunications (DECT)
ÇÖÖVD

SIST EN 300 175-8 V1.5.1:2005 en

iTeh STANDARD PREVIEW
(standards.iteh.ai)

SIST EN 300 175-8 V1.5.1:2005

<https://standards.iteh.ai/catalog/standards/sist/a9cf2d90-a6a3-48fc-811b-1e879bde4548/sist-en-300-175-8-v1-5-1-2005>

ETSI EN 300 175-8 V1.5.1 (2001-02)

European Standard (Telecommunications series)

Digital Enhanced Cordless Telecommunications (DECT); Common Interface (CI); Part 8: Speech coding and transmission

iTeh STANDARD PREVIEW
(standards.iteh.ai)

[SIST EN 300 175-8 V1.5.1:2005](https://standards.iteh.ai/catalog/standards/sist/a9cf2d90-a6a3-48fc-811b-1e879bde4548/sist-en-300-175-8-v1-5-1-2005)

<https://standards.iteh.ai/catalog/standards/sist/a9cf2d90-a6a3-48fc-811b-1e879bde4548/sist-en-300-175-8-v1-5-1-2005>



Reference

REN/DECT-000157-8

Keywords

DECT, radio, speech

ETSI

650 Route des Lucioles
F-06921 Sophia Antipolis Cedex - FRANCE

Tel.: +33 4 92 94 42 00 Fax: +33 4 93 65 47 16

Siret N° 348 623 562 00017 - NAF 742 C
Association à but non lucratif enregistrée à la
Sous-Préfecture de Grasse (06) N° 7803/88

iTeh STANDARD PREVIEW
(standards.iteh.ai)

SIST EN 300 175-8 V1.5.1:2005

<https://standards.iteh.ai/catalog/standards/sist/a9cf2d90-a6a3-48fc-811b-1e879bde4548/sist-en-300-175-8-v1-5-1-2005>

Important notice

Individual copies of the present document can be downloaded from:

<http://www.etsi.org>

The present document may be made available in more than one electronic version or in print. In any case of existing or perceived difference in contents between such versions, the reference version is the Portable Document Format (PDF). In case of dispute, the reference shall be the printing on ETSI printers of the PDF version kept on a specific network drive within ETSI Secretariat.

Users of the present document should be aware that the document may be subject to revision or change of status. Information on the current status of this and other ETSI documents is available at <http://www.etsi.org/tb/status/>

If you find errors in the present document, send your comment to:
editor@etsi.fr

Copyright Notification

No part may be reproduced except as authorized by written permission.
The copyright and the foregoing restriction extend to reproduction in all media.

© European Telecommunications Standards Institute 2001.
All rights reserved.

Contents

Intellectual Property Rights	6
Foreword	6
1 Scope	7
2 References	7
3 Definitions and abbreviations	8
3.1 Definitions	8
3.2 Abbreviations	9
4 Configurations	10
4.1 Reference configuration	10
4.1.1 Basic configuration	10
4.1.2 Portable Part (PP)	11
4.1.2.1 Functional organization	11
4.1.2.2 Volume control	12
4.1.3 Fixed Part (FP)	12
4.1.3.1 Digital interface	12
4.1.3.2 Analogue interface	13
4.1.3.3 FP adaptive volume control	13
4.2 Test configurations	13
5 Encoding	13
5.1 32 kbit/s full term (ADPCM)	13
5.1.1 Algorithm	13
5.1.2 Bit sequence	14
5.2 Other codings	14
6 Transmission aspects	14
6.1 Relative level	14
6.2 Acoustic reference level	14
6.3 Volume control	14
7 Speech performance characteristics	15
7.1 PP frequency responses	15
7.1.1 Sending	15
7.1.2 Receiving	15
7.2 PP sending and receiving loudness ratings	15
7.2.1 Nominal values	15
7.2.2 User-controlled volume control in PP	16
7.2.3 PP adaptive volume control	16
7.2.4 FP adaptive volume control	17
7.3 Sidetone	17
7.3.1 Talker sidetone	17
7.3.2 Listener sidetone	17
7.4 Terminal coupling loss	18
7.4.1 Weighted Terminal Coupling Loss (TLCw)	18
7.4.1.1 PP for the 3,1 kHz service (PSTN or ISDN)	18
7.4.1.2 FP with 4-wire interface	18
7.4.1.3 FP with analogue 2-wire interface	19
7.4.1.4 PP for unrestricted 64 kbit/s service	19
7.4.2 Stability loss	19
7.4.2.1 Requirement	19
7.4.2.2 Test conditions	19
7.4.2.3 Fixed geometry PP	19
7.4.2.4 Variable geometry PP	19
7.5 Distortion	19
7.5.1 Sending	19

iTeh STANDARD PREVIEW
(standards.iteh.ai)

[SIST EN 300 175-8 V1.5.1:2005](#)

[https://standards.iteh.ai/catalog/standards/sist/a9cf2d90-a6a3-48fc-811b-1e879bde4548/sist-en-300-175-8-v1-5-1-2005](#)

7.5.2	Receiving.....	19
7.5.3	Sidetone.....	20
7.5.4	Recommended value for network planning.....	20
7.6	Out of band signals.....	20
7.6.1	Sending (discrimination against out of band input signals).....	20
7.6.2	Receiving (spurious out of band signals).....	20
7.7	Noise.....	20
7.7.1	Sending.....	20
7.7.2	Narrow-band noise.....	20
7.7.3	Receiving.....	21
7.7.4	Level of sampling frequency (receiving).....	21
7.8	Acoustic shock.....	21
7.8.1	Continuous signal.....	21
7.8.2	Peak signal.....	21
7.9	Delay.....	21
7.9.1	DECT network.....	21
7.9.2	PP.....	21
7.9.3	FP.....	21
7.10	Network echo control.....	22
7.11	PP ambient noise rejection.....	22
7.12	Additional requirements for DECT systems provided with a 2-wire PSTN interface.....	22
7.12.1	General.....	23
7.12.1.1	Polarity independence.....	23
7.12.1.2	Feed Conditions.....	23
7.12.1.3	Power supply.....	23
7.12.2	Speech performance characteristics.....	23
7.12.2.1	Sensitivity/frequency response.....	23
7.12.2.2	Sending and Receiving Loudness Ratings (SLR and RLR).....	23
7.12.2.3	Distortion.....	23
7.12.2.4	Noise.....	24
7.12.2.5	Echo Return Loss.....	24
8	Additional features.....	24
8.1	Loudspeaking and hand-free facilities.....	24
8.2	Tandem with mobile radio network.....	24
8.2.1	Tandem with GSM.....	24
8.2.1.1	Network echo control.....	24
8.2.1.2	Terminal coupling loss.....	25
8.2.1.3	The GSM mobile transmitter operates in continuous mode.....	25
8.2.1.4	The GSM mobile transmitter operates in discontinuous mode, DTX.....	25
8.3	DECT connected to the GSM fixed network.....	25
8.3.1	Network echo control.....	25
8.3.2	Terminal coupling loss.....	25
8.4	Wireless Relay Stations (WRS).....	26
8.4.1	Modified FP network echo control requirements for implementation of 2 and 3 CRFP links in cascade.....	26
Annex A (informative): Description of "reference" echo control devices.....		27
A.1	Handset echo.....	27
A.1.1	Overview.....	27
A.1.1.1	Connection to the PSTN/ISDN.....	27
A.1.1.1.1	Local and national calls.....	27
A.1.1.1.2	Long distance connections with echo control devices in the PSTN/ISDN, e.g. calls via satellites.....	27
A.1.1.2	Connection to the GSM network.....	28
A.1.2	Implementation of the FP echo control function.....	28
A.1.2.1	Suppression threshold.....	29
A.1.2.2	Static characteristics of activation control.....	29
A.1.2.3	Dynamic characteristics of activation control.....	29
A.2	Network echo.....	30
A.2.1	Soft suppressor implementation of requirement 2.....	30
A.2.1.1	Static characteristics.....	31

A.2.1.2	Dynamic characteristics	31
A.2.2	Additional echo control for a 2-wire interface of requirement 1	31
A.2.3	Echo canceller used for both requirements 1 and 2	32
Annex B (informative):	Local loop application.....	33
B.1	DECT tethered local loop replacement with 2-wire PP end system	33
B.1.1	TCLw requirements.....	33
B.1.2	Network echo.....	34
B.2	Quantization distortion considerations.....	34
Annex C (informative):	GSM Discontinuous Transmission (DTX), and Voice Activity Detection (VAD).....	35
Annex D (informative):	Speech levels in relation to ambient room noise and examples of adaptive volume control settings	36
Annex E (informative):	Bibliography.....	37
History		38

iTeh STANDARD PREVIEW (standards.iteh.ai)

[SIST EN 300 175-8 V1.5.1:2005](https://standards.iteh.ai/catalog/standards/sist/a9cf2d90-a6a3-48fc-811b-1e879bde4548/sist-en-300-175-8-v1-5-1-2005)

<https://standards.iteh.ai/catalog/standards/sist/a9cf2d90-a6a3-48fc-811b-1e879bde4548/sist-en-300-175-8-v1-5-1-2005>

Intellectual Property Rights

IPRs essential or potentially essential to the present document may have been declared to ETSI. The information pertaining to these essential IPRs, if any, is publicly available for **ETSI members and non-members**, and can be found in ETSI SR 000 314: "*Intellectual Property Rights (IPRs); Essential, or potentially Essential, IPRs notified to ETSI in respect of ETSI standards*", which is available from the ETSI Secretariat. Latest updates are available on the ETSI Web server (<http://www.etsi.org/ipr>).

Pursuant to the ETSI IPR Policy, no investigation, including IPR searches, has been carried out by ETSI. No guarantee can be given as to the existence of other IPRs not referenced in ETSI SR 000 314 (or the updates on the ETSI Web server) which are, or may be, or may become, essential to the present document.

Foreword

This European Standard (Telecommunications series) has been produced by ETSI Project Digital Enhanced Cordless Telecommunications (DECT).

The present document is part 8 of a multi-part EN covering the Common Interface (CI) for the Digital Enhanced Cordless Telecommunications (DECT), as identified below:

- Part 1: "Overview";
- Part 2: "Physical Layer (PHL)";
- Part 3: "Medium Access Control (MAC) layer";
- Part 4: "Data Link Control (DLC) layer";
- Part 5: "Network (NWK) layer";
- Part 6: "Identities and addressing";
- Part 7: "Security features";
- Part 8: "Speech coding and transmission".**

Further details of the DECT system may be found in TR 101 178 [18] and ETR 043 [19].

National transposition dates	
Date of adoption of this EN:	16 February 2001
Date of latest announcement of this EN (doa):	31 May 2001
Date of latest publication of new National Standard or endorsement of this EN (dop/e):	30 November 2001
Date of withdrawal of any conflicting National Standard (dow):	30 November 2001

1 Scope

The present document gives an introduction and overview of the complete Digital Enhanced Cordless Telecommunications (DECT) Common Interface (CI).

This part of the DECT CI specifies the speech coding and transmission requirements.

In order to ensure satisfactory interworking of different portable and fixed units, it is necessary to specify the transmission performance of the analogue information over the digital link. This requires not only use of a common speech algorithm, but also standardization of frequency responses, reference speech levels (or loudness) at the air interface and various other parameters.

The present document applies to DECT equipment which includes all the necessary functions to provide real-time two-way speech conversation. A 3,1 kHz telephony teleservice conveyed over a DECT link (including Fixed Part (FP) and Portable Part (PP)) which is capable of being connected (directly or indirectly) to the public network access point has to comply with the requirements in the present document.

Tethered fixed point local loop applications are not required to comply with the requirements of the present document.

The speech performance characteristics defined in the present document typically conform to TBR 8 [13], which specifies the overall performance between the handset acoustic interface and a 64 kbit/s A-law Pulse Code Modulated (PCM) digital network interface. The deviations from TBR 8 [13] are mainly due to the consequences of non-PCM coding and transmission delay.

The additional features described in clause 8 are those which are not included in TBR 8 [13], but which are likely to occur in a DECT system: analogue interface, loudspeaking and hand-free facilities, tandeming with a mobile radio network. Headsets are not covered by the present specifications.

For the DECT systems which connect to the Public Switched Telephone Network (PSTN) via an analogue interface, the additional requirements, which have to be implemented in the FP, have as much as possible been aligned with TBR 38 [17].

ETSI/STC TM5 has prepared a technical report, ETR-041 [20], to be used as a guide for network planning.

A summary of the control and the use of the DECT echo control functions, to guide on need for options to manufacturers and installers, is found in annex A.

Information concerning test methods can be found in EN 300 176 [3]. The test methods take into account that DECT is a digital system.

2 References

The following documents contain provisions which, through reference in this text, constitute provisions of the present document.

- References are either specific (identified by date of publication, edition number, version number, etc.) or non-specific.
- For a specific reference, subsequent revisions do not apply.
- For a non-specific reference, the latest version applies.

- [1] ETSI EN 300 175-1: "Digital Enhanced Cordless Telecommunications (DECT); Common Interface (CI); Part 1: Overview".
- [2] ETSI EN 300 175-5: "Digital Enhanced Cordless Telecommunications (DECT); Common Interface (CI); Part 5: Network (NWK) layer".
- [3] ETSI EN 300 176 (all parts): "Digital Enhanced Cordless Telecommunications (DECT); Approval test specification".

- [4] ITU-T Recommendation G.101 (1996): "The transmission plan".
- [5] ITU-T Recommendation G.131 (1996): "Control of talker echo".
- [6] ITU-T Recommendation G.164 (1988): "Echo suppressors".
- [7] ITU-T Recommendation G.165 (1993): "Echo cancellers".
- [8] ITU-T Recommendation G.701 (1993): "Vocabulary of digital transmission and multiplexing, and pulse code modulation (PCM) terms".
- [9] ITU-T Recommendation G.726 (1990): "40, 32, 24, 16 kbit/s Adaptive Differential Pulse Code Modulation (ADPCM)".
- [10] ITU-T Recommendation I.241 (1988): "Teleservices supported by an ISDN".
- [11] ITU-T Recommendation P.10 (1993): "Vocabulary of terms on telephone transmission quality and telephone sets".
- [12] ITU-T Recommendation P.340 (1996): "Transmission characteristics of hands-free telephones".
- [13] ETSI TBR 008 (1998): "Integrated Services Digital Network (ISDN); Telephony 3,1 kHz telesevice; Attachment requirements for handset terminals".
- [14] ITU-T Recommendation G.113 (1996): "Transmission impairments".
- [15] ITU-T Recommendation G.111 (1993): "Loudness ratings (LRs) in an international connection".
- [16] ETSI ETS 300 540: "Digital cellular telecommunications system (Phase 2); Transmission planning aspects of the speech service in the GSM Public Land Mobile Network (PLMN) system (GSM 03.50 version 4.6.1)".
- [17] ETSI TBR 38 (1998): "Public Switched Telephone Network (PSTN); Attachment requirements for a terminal equipment incorporating an analogue handset function capable of supporting the justified case service when connected to the analogue interface of the PSTN in Europe".
<https://standards.iteh.ai/catalog/standards/sist/a9c12d90-a6a3-48fc-811b->
- [18] ETSI TR 101 178: "Digital Enhanced Cordless Telecommunications (DECT); A High Level Guide to the DECT Standardization".
- [19] ETSI ETR 043: "Digital Enhanced Cordless Telecommunications (DECT); Common Interface (CI); Services and facilities requirements specification".
- [20] ETSI ETR 041: "Transmission and Multiplexing (TM); Digital European Cordless Telecommunications (DECT); Transmission aspects 3,1 kHz telephony Interworking with other networks".

3 Definitions and abbreviations

3.1 Definitions

For the purposes of the present document, the relevant terms and definitions defined in ITU-T Recommendations P.10 [11], G.701 [8] and the following apply:

Cordless Radio Fixed Part (CRFP): see EN 300 175-1 [1]

double duplex bearer: see EN 300 175-1 [1]

End System (ES): see EN 300 175-1 [1]

fixed geometry Portable Part (PP): see EN 300 175-1 [1]

Fixed Part (DECT Fixed Part) (FP): see EN 300 175-1 [1]

Fixed radio Termination (FT): see EN 300 175-1 [1]

Generic Access Profile (GAP): see EN 300 175-1 [1]

handset echo: see EN 300 175-1 [1]

network (telecommunication network): see EN 300 175-1 [1]

network echo: see EN 300 175-1 [1]

operator (DECT operator): see EN 300 175-1 [1]

Portable Part (DECT Portable Part) (PP): see EN 300 175-1 [1]

Portable radio Termination (PT): see EN 300 175-1 [1]

public: see EN 300 175-1 [1]

public access service: see EN 300 175-1 [1]

Radio Fixed Part (RFP): see EN 300 175-1 [1]

Repeater Part (REP): see EN 300 175-1 [1]

service provider (telecommunications service provider): see EN 300 175-1 [1]

telephony service: see ITU-T Recommendation I.241 [10]

user (of a telecommunication network): see EN 300 175-1 [1]

variable geometry PP: see EN 300 175-1 [1]

Wireless Relay Station (WRS): see EN 300 175-1 [1]

STANDARD PREVIEW
(standards.iteh.ai)

3.2 Abbreviations

SIST EN 300 175-8 V1.5.1:2005

For the purposes of the present document, the relevant abbreviations defined in ITU-T Recommendations P.10 [11], G.701 [8] and the following apply:

ADPCM	Adaptive Differential Pulse Code Modulation
CI	Common Interface
CFRP	Cordless Radio Fixed Part
CLRR	Circuit Loudness Rating, Receiving
CLRS	Circuit Loudness Rating, Sending
CRFP	Cordless Radio Fixed Part
dBm	The absolute power level relative to 1 milliwatt, expressed in dB
dBm0	The absolute power level in dBm referred to a point of zero relative level (0 dBr point)
dBm0p	Psophometrically weighted absolute power level expressed in dBm referred to a point of zero relative level (0 dBr point)
dBPa	Sound pressure level relative to 1 Pa, expressed in dB
dBPa(A)	A-weighted sound pressure level relative to 1 Pa, expressed in dB
dBr	The relative power level of a signal in a transmission path referred to the level at a reference point on the path (0 dBr point)
DECT	Digital Enhanced Cordless Telecommunications
ERP	Ear Reference Point
ES	End System
EUT	Equipment Under Test
FP	Fixed Part
FT	Fixed radio Termination ⁷
GAP	Generic Access Profile
ISDN	Integrated Services Digital Network
LLe	Local Echo Loss
LSTR	Listener Sidetone Rating
MRP	Mouth Reference Point
NLP	Non-Linear Processor
NWK	Network

OLR	Overall Loudness Rating
P(A)BX	Private (Automatic) Branch Exchange
PCM	Pulse Code Modulated
PP	Portable Part
PSTN	Public Switched Telephone Network
PT	Portable radio Termination
ReFP	Reference Fixed Part
RePP	Reference Portable Part
REP	REpeater Part
RFP	Radio Fixed Part
RLR _H	Receiving Loudness Rating of the Handset
SLR _H	Sending Loudness Rating of the Handset
TCLw	weighted Terminal Coupling Loss
TDMA	Time Division Multiple Access
TELR	Talker's Echo Loudness Rating
STMR	Sidetone Masking Rating
QDU	Quantization Distortion Unit
WRS	Wireless Relay Station

4 Configurations

4.1 Reference configuration

4.1.1 Basic configuration

The basic reference configuration for voice transmission over DECT is shown in figure 1.

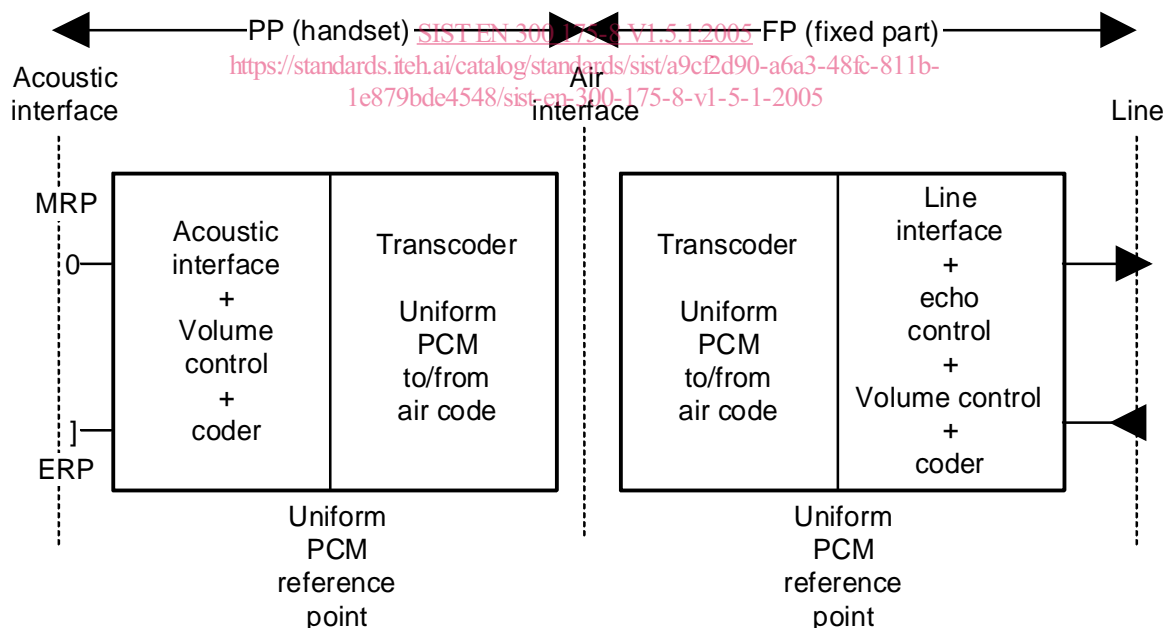

Figure 1: Basic reference configuration

The PP and the FP are delimited by physical interfaces:

- Acoustic:** from the PP towards the speaker-listener, with the Ear and Mouth Reference Points (ERP and MRP).
- Air(RF):** the interface between PP and FP.
- Line:** the interface from the FP towards the network.

Uniform PCM reference points shall be introduced in both the PP and the FP to materialize the limits of the transmission segment which is affected by the air interface coding scheme. This allows the transmission requirements to be specified independently from the coding at the air interface. The various transcoding algorithms are level-transparent, i.e. with an encoder and decoder connected in tandem, the "levels" of the digital signals at the uniform PCM input of the encoder and output from the decoder are identical. In a particular implementation, the reference points may be embedded within an IC, and thus will not be physically accessible.

Each of the three sections thus delimited deals with distinct functions:

- the PP electro-acoustic section (between acoustic interface and PP uniform PCM reference point) which includes the acoustic interface, the volume control and the analogue to digital conversion;
- the air-code section (between PP and FP uniform PCM reference points) considers the transcoding between uniform PCM and the air-code, as well as the transmission over the air interface;
- the FP line interface section (between FP uniform PCM reference point and line interface) comprises the interface to the line, digital or analogue, and the FP voice processing, e.g. echo control.

Typically, the transmission features shall conform to TBR 8 [13] for the PP electro-acoustic section, and the line interface section in the case of digital interface. In the case of analogue interface, the line interface section realizes in the FP the adaptation to clause 7.12 and to the relevant attachment requirements.

4.1.2 Portable Part (PP)

4.1.2.1 Functional organization

Figure 2 represents the basic functional organization of a PP from the voice transmission point of view:

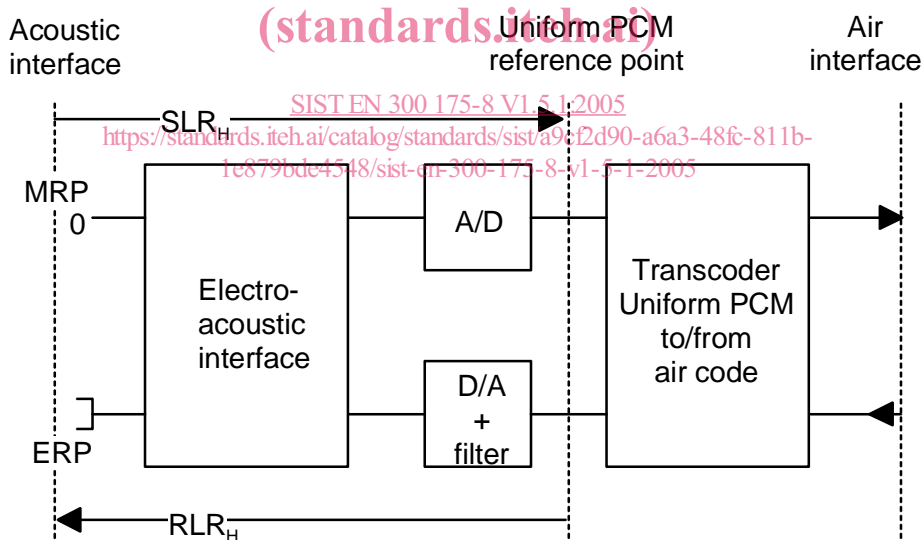

Figure 2: PP functional organization

The various functions represented in figure 2 are:

- the electro-acoustic function, which performs the interface to the transducers and the volume control. The Handset Loudness Ratings (SLR_H) and (RLR_H) are defined between the acoustic interface and the uniform PCM reference point;
- the analogue to digital and digital to analogue coding to the uniform PCM reference point;
- the transcoder between uniform PCM and air-code.