

FINAL
DRAFT

INTERNATIONAL
STANDARD

ISO/FDIS
1352

ISO/TC 164/SC 4

Secretariat: ANSI

Voting begins on:
2021-10-01

Voting terminates on:
2021-11-26

Metallic materials — Torque-controlled fatigue testing

Matériaux métalliques — Essais de fatigue par couple de torsion commandé

iTeh STANDARD PREVIEW
(standards.iteh.ai)

[ISO/FDIS 1352](https://standards.iteh.ai/catalog/standards/sist/d9a7d05c-3183-4ccd-bace-817c11fa240e/iso-fdis-1352)

<https://standards.iteh.ai/catalog/standards/sist/d9a7d05c-3183-4ccd-bace-817c11fa240e/iso-fdis-1352>

RECIPIENTS OF THIS DRAFT ARE INVITED TO SUBMIT, WITH THEIR COMMENTS, NOTIFICATION OF ANY RELEVANT PATENT RIGHTS OF WHICH THEY ARE AWARE AND TO PROVIDE SUPPORTING DOCUMENTATION.

IN ADDITION TO THEIR EVALUATION AS BEING ACCEPTABLE FOR INDUSTRIAL, TECHNOLOGICAL, COMMERCIAL AND USER PURPOSES, DRAFT INTERNATIONAL STANDARDS MAY ON OCCASION HAVE TO BE CONSIDERED IN THE LIGHT OF THEIR POTENTIAL TO BECOME STANDARDS TO WHICH REFERENCE MAY BE MADE IN NATIONAL REGULATIONS.



Reference number
ISO/FDIS 1352:2021(E)

© ISO 2021

iTeh STANDARD PREVIEW
(standards.iteh.ai)

[ISO/FDIS 1352](https://standards.iteh.ai/catalog/standards/sist/d9a7d05c-3183-4ccd-bace-817c11fa240e/iso-fdis-1352)

<https://standards.iteh.ai/catalog/standards/sist/d9a7d05c-3183-4ccd-bace-817c11fa240e/iso-fdis-1352>



COPYRIGHT PROTECTED DOCUMENT

© ISO 2021

All rights reserved. Unless otherwise specified, or required in the context of its implementation, no part of this publication may be reproduced or utilized otherwise in any form or by any means, electronic or mechanical, including photocopying, or posting on the internet or an intranet, without prior written permission. Permission can be requested from either ISO at the address below or ISO's member body in the country of the requester.

ISO copyright office
CP 401 • Ch. de Blandonnet 8
CH-1214 Vernier, Geneva
Phone: +41 22 749 01 11
Email: copyright@iso.org
Website: www.iso.org

Published in Switzerland

Contents

	Page
Foreword.....	v
1 Scope.....	1
2 Normative references.....	1
3 Terms and definitions.....	1
4 Symbols and abbreviated terms.....	3
5 Principle of test.....	4
6 Test plan.....	5
7 Shape and size of specimen.....	5
7.1 Form.....	5
7.2 Dimensions.....	7
7.2.1 Specimens of circular cross-section.....	7
7.2.2 Specimens with tubular cross-section.....	8
8 Preparation of specimens.....	8
8.1 General.....	8
8.2 Machining procedure.....	8
8.3 Sampling and marking.....	9
8.4 Surface conditions of specimen.....	9
8.5 Dimensional checks.....	10
8.6 Storage and handling.....	10
9 Apparatus.....	10
9.1 Testing machine.....	10
9.1.1 General.....	10
9.1.2 Torque cell.....	10
9.1.3 Gripping of specimen.....	11
9.1.4 Alignment check.....	11
9.1.5 Axial force.....	11
9.2 Heating system.....	12
9.3 Instrumentation for test monitoring.....	12
9.3.1 Recording system.....	12
9.3.2 Cycle counter.....	12
9.3.3 Checking and verification.....	12
10 Test procedure.....	13
10.1 Mounting of specimen.....	13
10.2 Frequency of testing.....	13
10.3 Heating for the isothermal elevated temperature test.....	13
10.4 Application of torque.....	13
10.5 Calculation of nominal torsional (shear) stress.....	13
10.6 Recording of temperature and humidity.....	14
10.7 Failure and termination criteria.....	14
10.7.1 Failure.....	14
10.7.2 Termination.....	14
11 Measurement uncertainty.....	14
12 Test report.....	14
Annex A (informative) Presentation of results.....	16
Annex B (informative) Verification of alignment of torsional fatigue testing machines.....	19
Annex C (informative) Measuring uniformity of torsional strain (stress) state.....	21
Annex D (informative) Estimation of measurement uncertainty.....	24

iTeh STANDARD PREVIEW
(standards.iteh.ai)

[ISO/FDIS 1352](https://standards.iteh.ai/catalog/standards/sist/d9a7d05c-3183-4ccd-bace-817c11fa240e/iso-fdis-1352)

<https://standards.iteh.ai/catalog/standards/sist/d9a7d05c-3183-4ccd-bace-817c11fa240e/iso-fdis-1352>

Foreword

ISO (the International Organization for Standardization) is a worldwide federation of national standards bodies (ISO member bodies). The work of preparing International Standards is normally carried out through ISO technical committees. Each member body interested in a subject for which a technical committee has been established has the right to be represented on that committee. International organizations, governmental and non-governmental, in liaison with ISO, also take part in the work. ISO collaborates closely with the International Electrotechnical Commission (IEC) on all matters of electrotechnical standardization.

The procedures used to develop this document and those intended for its further maintenance are described in the ISO/IEC Directives, Part 1. In particular, the different approval criteria needed for the different types of ISO documents should be noted. This document was drafted in accordance with the editorial rules of the ISO/IEC Directives, Part 2 (see www.iso.org/directives).

Attention is drawn to the possibility that some of the elements of this document may be the subject of patent rights. ISO shall not be held responsible for identifying any or all such patent rights. Details of any patent rights identified during the development of the document will be in the Introduction and/or on the ISO list of patent declarations received (see www.iso.org/patents).

Any trade name used in this document is information given for the convenience of users and does not constitute an endorsement.

For an explanation of the voluntary nature of standards, the meaning of ISO specific terms and expressions related to conformity assessment, as well as information about ISO's adherence to the World Trade Organization (WTO) principles in the Technical Barriers to Trade (TBT), see www.iso.org/iso/foreword.html (standards.iteh.ai)

This document was prepared by Technical Committee ISO/TC 164, *Mechanical testing of metals*, Subcommittee SC 4, *Fatigue, fracture and toughness testing*.

This third edition cancels and replaces the second edition (ISO 1352:2011), which has been technically revised.

The main changes compared to the previous edition are as follows:

- addition of the test apparatus and procedure for the elevated temperature testing;
- addition of measurement uncertainty estimation.

Any feedback or questions on this document should be directed to the user's national standards body. A complete listing of these bodies can be found at www.iso.org/members.html.

iTeh STANDARD PREVIEW
(standards.iteh.ai)

ISO/FDIS 1352

<https://standards.iteh.ai/catalog/standards/sist/d9a7d05c-3183-4ccd-bace-817c11fa240e/iso-fdis-1352>

Metallic materials — Torque-controlled fatigue testing

1 Scope

This document specifies the conditions for performing torsional, constant-amplitude, nominally elastic stress fatigue tests on metallic specimens without deliberately introducing stress concentrations. The tests are typically carried out at ambient temperature or an elevated temperature in air by applying a pure couple to the specimen about its longitudinal axis.

While the form, preparation and testing of specimens of circular cross-section and tubular cross-section are described in this document, component and other specialized types of testing are not included. Similarly, low-cycle torsional fatigue tests carried out under constant-amplitude angular displacement control, which lead to failure in a few thousand cycles, are also excluded.

2 Normative references

The following documents are referred to in the text in such a way that some or all of their content constitutes requirements of this document. For dated references, only the edition cited applies. For undated references, the latest edition of the referenced document (including any amendments) applies.

ISO 554:1976, *Standard atmospheres for conditioning and/or testing — Specifications*

ISO 23788, *Metallic materials — Verification of the alignment of fatigue testing machines*

3 Terms and definitions

ISO/FDIS 1352

[https://standards.iteh.ai/catalog/standards/sist/d9a7d05c-3183-4ccd-bace-](https://standards.iteh.ai/catalog/standards/sist/d9a7d05c-3183-4ccd-bace-817c116240e/iso-fdis-1352)

[817c116240e/iso-fdis-1352](https://standards.iteh.ai/catalog/standards/sist/d9a7d05c-3183-4ccd-bace-817c116240e/iso-fdis-1352)

For the purposes of this document, the following terms and definitions apply.

ISO and IEC maintain terminological databases for use in standardization at the following addresses:

— ISO Online browsing platform: available at <https://www.iso.org/obp>

— IEC Electropedia: available at <http://www.electropedia.org/>

3.1

maximum stress

τ_{\max}

highest algebraic value of shear stress at the outer diameter in the stress cycle

Note 1 to entry: See [Figure 1](#).

3.2

minimum stress

τ_{\min}

lowest algebraic value of shear stress in the stress cycle

Note 1 to entry: See [Figure 1](#).

3.3

mean stress

τ_m

static component of the shear stress

Note 1 to entry: It is one half of the algebraic sum of the maximum shear stress and the minimum shear stress:

$$\tau_m = \frac{\tau_{\max} + \tau_{\min}}{2}$$

**3.4
stress amplitude**

τ_a
variable component of shear stress

Note 1 to entry: It is one half of the algebraic difference between the maximum shear stress and the minimum shear stress:

$$\tau_a = \frac{\tau_{\max} - \tau_{\min}}{2}$$

**3.5
number of cycles**

N
number of cycles applied at any stage during the test

**3.6
stress ratio**

R
algebraic ratio of the minimum shear stress to the maximum shear stress in one cycle

Note 1 to entry: It is expressed as:

$$R = \frac{\tau_{\min}}{\tau_{\max}}$$

ITEH STANDARD PREVIEW
(standards.iteh.ai)

**3.7
stress range**

$\Delta\tau$
range between the maximum and minimum shear stresses

<https://standards.iteh.ai/catalog/standards/sist/d9a7d05c-3183-4ccd-bace-817c11fa240e/iso-fdis-1352>

Note 1 to entry: It is expressed as:

$$\Delta\tau = \tau_{\max} - \tau_{\min}$$

**3.8
fatigue life at failure**

N_f
number of stress cycles to failure in a specified condition

**3.9
fatigue strength at N cycles**

τ_N
value of the shear stress amplitude (3.4) at a stated stress ratio (3.6) under which the specimen would have a life of N cycles

**3.10
torque**

M
twisting couple producing shear stress or twisting deformation about the axis of the specimen

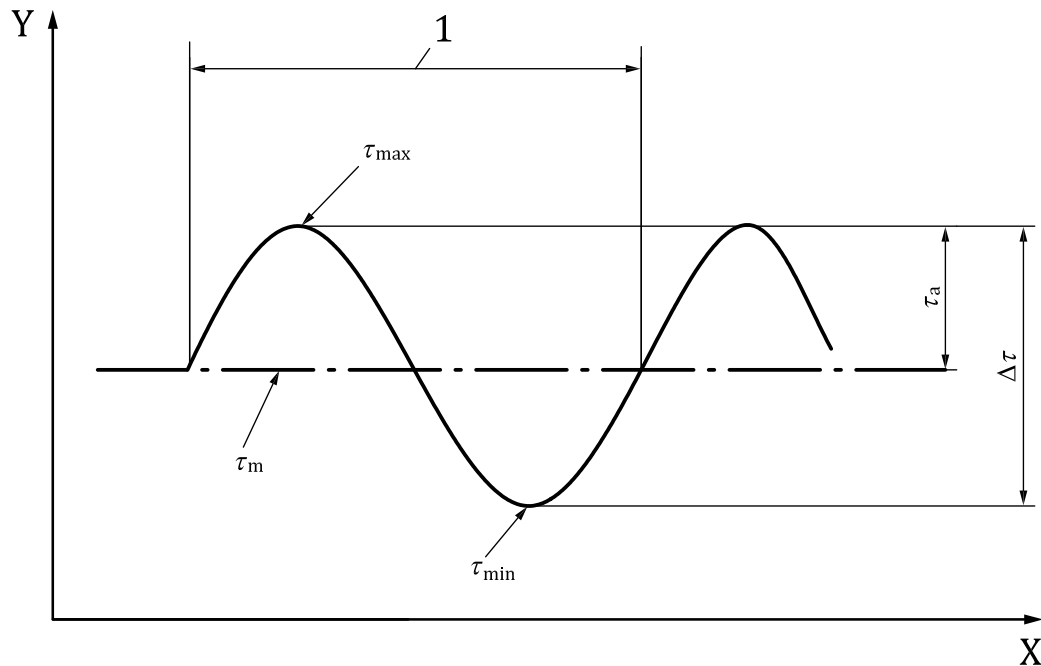
**Key**

- X time
 Y stress
 1 one stress cycle

iTeh STANDARD PREVIEW
(standards.iteh.ai)

Figure 1 — Fatigue stress cycle

[ISO/FDIS 1352](https://standards.iteh.ai/catalog/standards/sist/d9a7d05c-3183-4ccd-bace-817c11fa240e/iso-fdis-1352)

<https://standards.iteh.ai/catalog/standards/sist/d9a7d05c-3183-4ccd-bace-817c11fa240e/iso-fdis-1352>

4 Symbols and abbreviated terms

D diameter or width across flats of the gripped ends of the specimen

NOTE 1 The value of *D* may be different for each end of the specimen.

d diameter of specimen of circular cross-section

*d*_o outer diameter of test section of specimen of tubular cross-section

*d*_i inner diameter of test section of specimen of tubular cross-section

*L*_g axial separation of strain gauges

*L*_p parallel length

r transition blending radius at ends of test section which starts the transition from *d* to *D* (see [Figures 3](#) and [4](#))

NOTE 2 This curve need not be a true arc of a circle over the whole of the distance between the end of the test section and the start of the enlarged end for specimens of the types shown in [Figure 3](#).

t wall thickness in the test section of the thin-walled tube specimen

T specified temperature at which the test should be performed

T_i	indicated temperature or measure temperature on the surface of the parallel length of the specimen
ϵ_a	linear normal strain in the 0° directions of the 45° strain rosette
ϵ_b	linear normal strain in the 45° directions of the 45° strain rosette
ϵ_c	linear normal strain in the 90° directions of the 45° strain rosette
$\epsilon_{\theta\theta}$	circumferential strain
ϵ_{zz}	longitudinal strain
$\gamma_{\theta z}$	shear strain

5 Principle of test

Nominally identical specimens are mounted on a torsional fatigue testing machine and subjected to the loading condition required to introduce cycles of torsional stress. Any one of the types of cyclic stress illustrated in [Figure 2](#) may be used. The test waveform shall be constant-amplitude sinusoidal, unless otherwise specified.

In an axially symmetrical specimen, change of mean torque does not introduce a different type of stress system and mean stress in torsion may always be regarded as positive in sign.

The torque is applied to the specimen about the longitudinal axis passing through the centroid of the cross-section.

The test is continued until the specimen fails or until a predetermined number of stress cycles has been exceeded.

NOTE Typically, cracks produced by torsional fatigue testing are parallel or orthogonal to the longitudinal axis (shear stress driven) or helical at approximately +/-45° to the longitudinal axis (principal stress driven).

Tests conducted at ambient temperature shall be performed between 10 °C and 35 °C unless otherwise agreed with the customer.

The results of fatigue testing can be affected by atmospheric conditions, and where controlled conditions are required, ISO 554:1976, 2.1, applies.

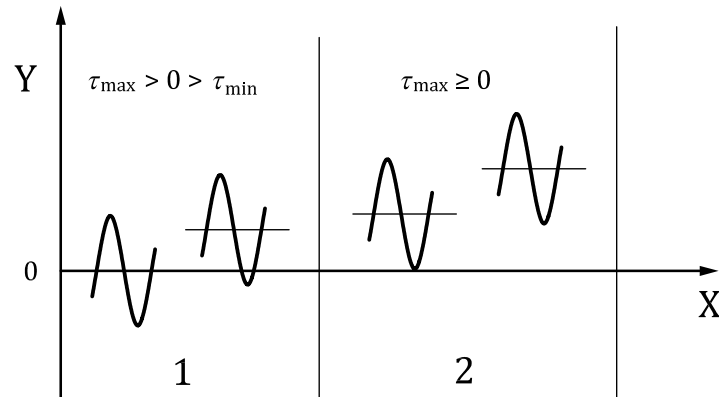
**Key**

- X time
 Y stress
 1 reversed
 2 fluctuating

Figure 2 — Types of cyclic stress**6 Test plan****iTeh STANDARD PREVIEW**

Before commencing testing, the following shall be agreed by the parties concerned and any modifications shall be mutually agreed upon:

- a) the form of specimen to be used (see [Clause 7](#));
- b) the stress ratio(s) to be used;
- c) the objective of the tests, i.e. which of the following is to be determined:
 - the fatigue life at a specified stress amplitude;
 - the fatigue strength at a specified number of cycles;
 - a full Wöhler or S-N curve;
- d) the number of specimens to be tested and the test sequence;
- e) the number of cycles a specimen is subjected to before the test is terminated.

NOTE 1 Some methods of data presentation are given in [Annex A](#). See ISO 12107^[3] for details, including data analysis procedure and statistical presentation.

NOTE 2 Commonly employed numbers of cycles for test termination are:

- 10^7 cycles for structural steels, and
- 10^8 cycles for other steels and non-ferrous alloys.

7 Shape and size of specimen**7.1 Form**

Generally, a specimen having a fully machined test section of one of the types shown in [Figures 3](#) and [4](#) should be used.

The specimen may be of:

- solid circular cross-section, with tangentially blending fillets between the test section and the ends (see [Figure 3](#)); or
- tubular cross-section, with tangentially blending fillets between the test section and the ends in the outer surface (see [Figure 4](#)).

The hourglass specimen is not recommended because the crack under torsional loads may propagate at 45° to the loading axis.

For tubular specimens, the diameter of the inner surface at the ends may be greater than or equal to that at the test section. For a specimen having an inner diameter at the ends greater than that at the test section, crack initiation or failure outside the test section invalidates the test, which should be counted as a discontinued (stopped) test at the number of cycles completed.

Fatigue test results determined using the specimen of tubular cross-section are not always comparable to those obtained from the specimen of solid circular cross-section (due to absence or existence of elastic constraint). Therefore, caution should be exercised when comparing fatigue lives obtained on the same material from specimens having different cross-sections.

Typical specimen ends are shown in [Figure 5](#). It is recommended that ends suitable for meeting the alignment criterion be chosen.

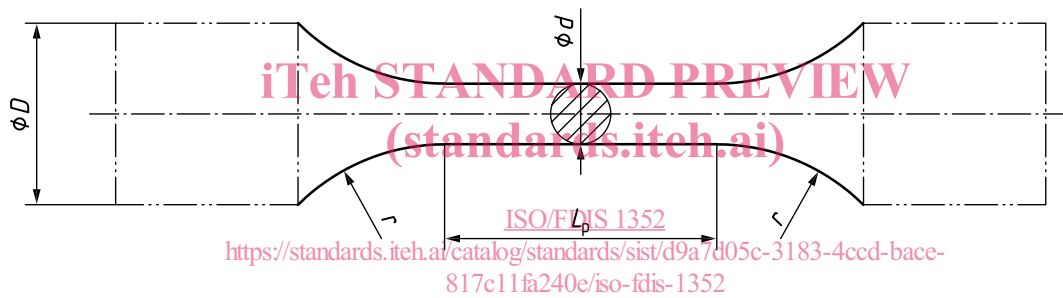

Figure 3 — Specimens with circular cross-section

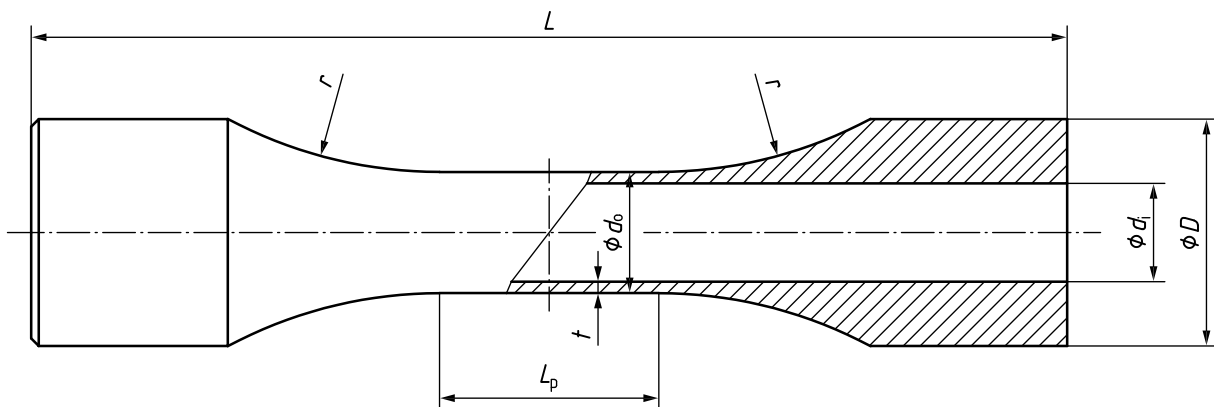

Figure 4 — Specimen with tubular cross-section