

---

---

**Fire resistance tests — Fire dampers  
for air distribution systems —**

**Part 2:  
Intumescent dampers**

*Essais de résistance au feu — Clapets résistant au feu pour des  
systèmes de distribution d'air*

*Partie 2: Clapets intumescents*

iTeh STANDARD PREVIEW  
(standards.iteh.ai)

ISO 21925-2:2021

<https://standards.iteh.ai/catalog/standards/sist/17985c68-aaad-4f20-8155-621f5fe6ebd9/iso-21925-2-2021>



## iTeh STANDARD PREVIEW (standards.iteh.ai)

ISO 21925-2:2021

<https://standards.iteh.ai/catalog/standards/sist/17985c68-aaad-4f20-8155-621f5fe6ebd9/iso-21925-2-2021>



### **COPYRIGHT PROTECTED DOCUMENT**

© ISO 2021

All rights reserved. Unless otherwise specified, or required in the context of its implementation, no part of this publication may be reproduced or utilized otherwise in any form or by any means, electronic or mechanical, including photocopying, or posting on the internet or an intranet, without prior written permission. Permission can be requested from either ISO at the address below or ISO's member body in the country of the requester.

ISO copyright office  
CP 401 • Ch. de Blandonnet 8  
CH-1214 Vernier, Geneva  
Phone: +41 22 749 01 11  
Email: [copyright@iso.org](mailto:copyright@iso.org)  
Website: [www.iso.org](http://www.iso.org)

Published in Switzerland

# Contents

	Page
Foreword.....	iv
<b>1 Scope.....</b>	<b>1</b>
<b>2 Normative references.....</b>	<b>1</b>
<b>3 Terms and definitions.....</b>	<b>1</b>
<b>4 Principles of the test.....</b>	<b>2</b>
<b>5 Apparatus.....</b>	<b>3</b>
<b>6 Test construction.....</b>	<b>12</b>
6.1 General.....	12
6.1.1 Introduction.....	12
6.1.2 Side to be tested.....	13
6.1.3 Dampers installed in both walls and floors.....	13
6.1.4 Dampers installed within a structural opening.....	13
6.1.5 Dampers mounted onto face of wall or floor.....	13
6.1.6 Dampers remote from wall or floor.....	13
6.1.7 Minimum separation between dampers.....	13
6.2 Size of specimen.....	13
6.3 Specimen installation.....	15
6.4 Supporting construction.....	15
6.4.1 Principles.....	15
6.4.2 Recommended supporting constructions.....	16
6.5 Conditioning.....	17
<b>7 Determination of leakage of connecting duct and measuring station.....</b>	<b>17</b>
<b>8 Opening and closing cycles.....</b>	<b>17</b>
<b>9 Fire test.....</b>	<b>18</b>
<b>10 Classification and criteria.....</b>	<b>19</b>
10.1 General.....	19
10.2 Number of tests required.....	19
<b>11 Test report.....</b>	<b>20</b>
<b>12 Direct field of application of the test results.....</b>	<b>21</b>
12.1 Size of fire damper.....	21
12.2 Fire dampers installed within structural openings.....	21
12.3 Fire dampers mounted onto the face of a wall.....	21
12.4 Fire dampers remote from a wall or floor.....	21
12.5 Separation between fire dampers and between fire dampers and construction elements.....	22
12.6 Supporting constructions.....	22
<b>Annex A (normative) Durability.....</b>	<b>23</b>
<b>Annex B (informative) Test apparatus.....</b>	<b>24</b>
<b>Annex C (informative) Reaction to fire tests — Intumescent materials.....</b>	<b>26</b>
<b>Annex D (informative) The use and application of intumescent fire dampers in ducted air distribution systems.....</b>	<b>37</b>
<b>Bibliography.....</b>	<b>44</b>

## Foreword

ISO (the International Organization for Standardization) is a worldwide federation of national standards bodies (ISO member bodies). The work of preparing International Standards is normally carried out through ISO technical committees. Each member body interested in a subject for which a technical committee has been established has the right to be represented on that committee. International organizations, governmental and non-governmental, in liaison with ISO, also take part in the work. ISO collaborates closely with the International Electrotechnical Commission (IEC) on all matters of electrotechnical standardization.

The procedures used to develop this document and those intended for its further maintenance are described in the ISO/IEC Directives, Part 1. In particular, the different approval criteria needed for the different types of ISO documents should be noted. This document was drafted in accordance with the editorial rules of the ISO/IEC Directives, Part 2 (see [www.iso.org/directives](http://www.iso.org/directives)).

Attention is drawn to the possibility that some of the elements of this document may be the subject of patent rights. ISO shall not be held responsible for identifying any or all such patent rights. Details of any patent rights identified during the development of the document will be in the Introduction and/or on the ISO list of patent declarations received (see [www.iso.org/patents](http://www.iso.org/patents)).

Any trade name used in this document is information given for the convenience of users and does not constitute an endorsement.

For an explanation of the voluntary nature of standards, the meaning of ISO specific terms and expressions related to conformity assessment, as well as information about ISO's adherence to the World Trade Organization (WTO) principles in the Technical Barriers to Trade (TBT), see [www.iso.org/iso/foreword.html](http://www.iso.org/iso/foreword.html).

This document was prepared by Technical Committee ISO/TC 92, *Fire Safety*, Subcommittee SC 2, *Fire containment*.

<https://standards.iteh.ai/catalog/standards/sist/17985c68-aaad-4f20-8155-62456641d11c/iso-21925-2:2021>

A list of all parts in the ISO 21925 series can be found on the ISO website.

Any feedback or questions on this document should be directed to the user's national standards body. A complete listing of these bodies can be found at [www.iso.org/members.html](http://www.iso.org/members.html).

# Fire resistance tests — Fire dampers for air distribution systems —

## Part 2: Intumescent dampers

**WARNING** — For suitable health precautions to be taken, attention is drawn to the possibility that toxic or harmful gases can be released while the test is being conducted.

### 1 Scope

This document specifies a test method for the determination of the resistance of fire dampers to heat, and for the evaluation of their ability to prevent fire and smoke from spreading from one fire compartment to another through an air distribution system.

This document describes the test requirements related to intumescent fire dampers. It is intended for intumescent fire dampers that are expected to be classified as EI dampers. Without the addition of a mechanical damper, they are unable to achieve the “S” classification, which includes a leakage limit imposed at ambient temperature.

This document is not intended to be used for dampers used only in smoke control systems, for testing fire protection devices which only deal with air transfer applications, or for dampers used in suspended ceilings, as the installation of the damper and duct can have an adverse effect on the performance of the suspended ceiling, requiring other methods of evaluation.

NOTE “Air transfer” is a low-pressure application through a fire separation door (or wall, floor) without any connection to an air duct.

### 2 Normative references

The following documents are referred to in the text in such a way that some or all of their content constitutes requirements of this document. For dated references, only the edition cited applies. For undated references, the latest edition of the referenced document (including any amendments) applies.

ISO 834-1, *Fire-resistance tests — Elements of building construction — Part 1: General requirements*

ISO 5167-1, *Measurement of fluid flow by means of pressure differential devices inserted in circular cross-section conduits running full — Part 1: General principles and requirements*

### 3 Terms and definitions

For the purposes of this document, the following terms and definitions apply.

ISO and IEC maintain terminological databases for use in standardization at the following addresses:

- ISO Online browsing platform: available at <https://www.iso.org/obp>
- IEC Electropedia: available at <http://www.electropedia.org/>

#### 3.1

##### test construction

complete test assembly, consisting of the *separating element* (3.3), damper and duct sections and penetration seals (if any)

**3.2  
supporting construction**

wall, partition or floor into which the damper and duct section are installed for the test

**3.3  
separating element**

wall, partition or floor into which the damper and duct are installed in the building

**3.4  
connecting duct**

duct section between the damper or *separating element* (3.3) and the *measuring station* (3.5)

**3.5  
measuring station**

equipment consisting of pipe system with an orifice plate or venturi and an air flow straightener (if required), installed between the *connecting duct* (3.4) and the *exhaust equipment* (3.6) to determine the volume flow rate of gases passing through the damper under test

**3.6  
exhaust equipment**

equipment consisting of a fan and balancing or dilution dampers to apply and maintain the underpressure in the *connecting duct* (3.4)

**3.7  
fire damper**

mobile closure within a duct which is operated automatically or manually and is designed to prevent the spread of fire

**3.8  
intumescent**

term describing the phenomenon of expansion in excess of normal thermal expansion under the action of heat normally generated by the fire

**3.9  
intumescent dampers**

non-mechanical device installed in a ducted system that intumesces when exposed to hot gases to prevent the spread of fire

**3.10  
intumescent sheet**

*intumescent* (3.8) material manufactured in rigid or flexible thin sections, typically 1 mm to 4 mm thick, usually cut into strips for incorporation into the *fire damper* (3.7)

**3.11  
covered intumescent**

partly enclosed *intumescent* (3.8) material to provide protection, modify the behaviour, improve the surface finish and/or enhance the aesthetics of the *fire damper* (3.7)

**3.12  
skinned intumescent material**

totally enclosed *intumescent* (3.8) material on all faces and edges to provide protection, modify the behaviour and improve the surface finish and/or the aesthetics of the *fire damper* (3.7)

## 4 Principles of the test

### 4.1 General

The damper with its fixing device is built into, or attached directly or remotely via a section of ducting, to a fire-separating building element according to good practice. Temperature and integrity measurements are carried out in various parts of the test construction during the test. The tightness of

the damper system is measured by direct flow measurements whilst maintaining a constant pressure differential across the closed damper of 300 Pa. For special applications, higher underpressures may be employed.

#### 4.2 Additional tests

Additional tests are included to provide an assessment on the operational reliability of the intumescent dampers. See [Annex C](#) for information on reaction to fire tests. The conditions specified in [Annex A](#) apply.

[Annex D](#) provides general information on the use and application of intumescent dampers.

## 5 Apparatus

### 5.1 General

The test apparatus specified in [5.2](#) to [5.11](#), including the instrumentation, shall be in accordance with ISO 834-1 except where specifically stated otherwise. Intumescent dampers give off some moisture. A suitable condensing device shall therefore be installed before the flow-measuring device. This will be deemed to be effective if the gas temperature within the flow-measuring device does not exceed 40 °C at any time during the test. An example of a suitable condensing device is a water tank fed with water at ambient temperature with approximately 9 m of measuring duct immersed in the tank prior to reaching the measuring device.

An example of a test arrangement is shown in [Figure 1](#).

**5.2 Furnace**, capable of achieving the heating and pressure conditions specified in ISO 834-1.

**5.3 Damper under test**, attached to the connecting duct in accordance with the manufacturer's instructions.

**5.4 Connecting duct**, of all welded construction fabricated from (1,5 ± 0,1) mm thick steel with a width and height appropriate to the size of the damper under test. The duct shall have a length of twice the diagonal dimension of the damper, up to a maximum of 2 m. The connecting duct shall be provided with a gas-tight observation port.

**5.5 Measuring station**, consisting of an orifice plate, venturi, or other suitable device, an air flow straightener (if required) and straight lengths of pipe sized in accordance with ISO 5167-1 installed between the connecting duct and the exhaust fan to determine the volume flow rate of gases passing through the damper under test. When testing dampers installed in floors, it is still possible to use the measuring station horizontally. A suitable mounting detail is shown in [Figure 2](#).

**5.6 Exhaust fan system**, capable of controlling flow rates and maintaining a pressure difference between the connecting duct and the furnace, as required, when the damper is closed.

Regardless of what test pressure is chosen, the fan should be capable of achieving a 200 Pa pressure difference higher than the test pressure difference chosen for the test.

Regulation of the 300 Pa (or higher pressure differential) may be by means of a dilution damper installed just before the fan inlet. The pressure shall be controlled to within ±5 % of the required pressure. A balancing damper shall be fitted at the outlet of the fan to adjust the pressure range of the systems to suit the damper under test. A variable speed fan may be used instead of the dilution damper.

**5.7 Instrumentation for measuring and recording the furnace temperature**, in accordance with ISO 834-1. Locations of the furnace thermocouples for a number of different test arrangements are shown in [Figures 3, 4, 5, 6, 7](#) and [8](#).

The gas temperature adjacent to the flow measuring device shall be measured by a 0,25 mm bare wire thermocouple enclosed in a 6 mm diameter porcelain twin wall tube with its measuring junction located at the centreline of the measuring duct and at a distance equal to twice the diameter of the measuring duct downstream from the flow measuring device. A similar thermocouple shall be located at the exit from the connecting duct plenum (see [Figures 1](#) and [2](#)). Alternative thermocouples may be used provided it can be shown that they have equivalent response time.

**5.8 Instrumentation for measuring and recording surface temperature**, in accordance with ISO 834-1. This shall be located in the positions shown in [Figures 3, 4, 5, 6, 7](#) or [8](#), depending on the method of mounting the damper selected.

**5.9 Instrumentation for measuring pressure differential between the furnace and the connecting duct**. A pressure tapping shall be located on the centreline of one vertical side wall of the connecting duct. Instrumentation shall have a 300 Pa measurement capacity higher than the test pressure chosen for the test. Instrumentation shall also be provided for measuring the pressure difference between inside and outside (ambient) of the furnace.

**5.10 Timing device**, capable of running throughout the test period.

**5.11 Gap gauges and cotton pad**, according to ISO 834-1, to judge the integrity of the joints between the damper and its connecting duct and the damper assembly and the supporting construction of the test arrangement.

ITIH STANDARD PREVIEW  
(standards.iteh.ai)  
ISO 21925-2:2021  
<https://standards.iteh.ai/catalog/standards/sist/17985c68-aaad-4f20-8155-621f5fe6ebd9/iso-21925-2-2021>



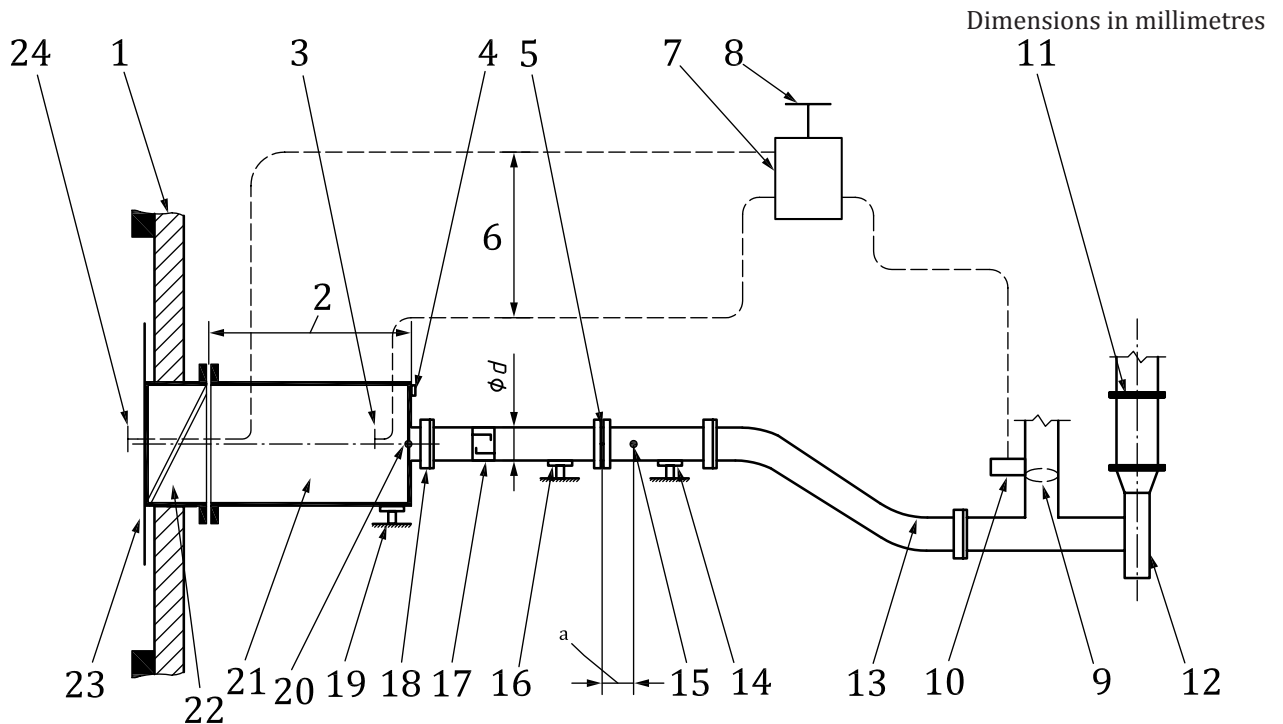

**Key**

- 1 supporting construction (wall)
  - 2  $2 \times$  diagonal dimension of the damper (to a maximum of 2 m)
  - 3 pressure sensor (on centreline)
  - 4 observation port
  - 5 orifice plate or venturi
  - 6 pressure differential (300 Pa)
  - 7 pressure differential control box
  - 8 pressure sensor in laboratory
  - 9 pressure control dilution damper
  - 10 pneumatic actuator or manual control
  - 11 balancing damper
  - 12 fan
  - 13 flexible connecting duct
  - 14 support
  - 15 thermocouple
  - 16 support
  - 17 flow straightener
  - 18 flange
  - 19 support
  - 20 thermocouple at exit from plenum
  - 21 connecting duct
  - 22 test damper
  - 23 furnace chamber
  - 24 pressure sensor (on centreline of damper)
- <sup>a</sup> Distance from thermocouple to orifice plate =  $2 \times$  diameter of the measuring duct.

**Figure 1 — Example of general test arrangement**

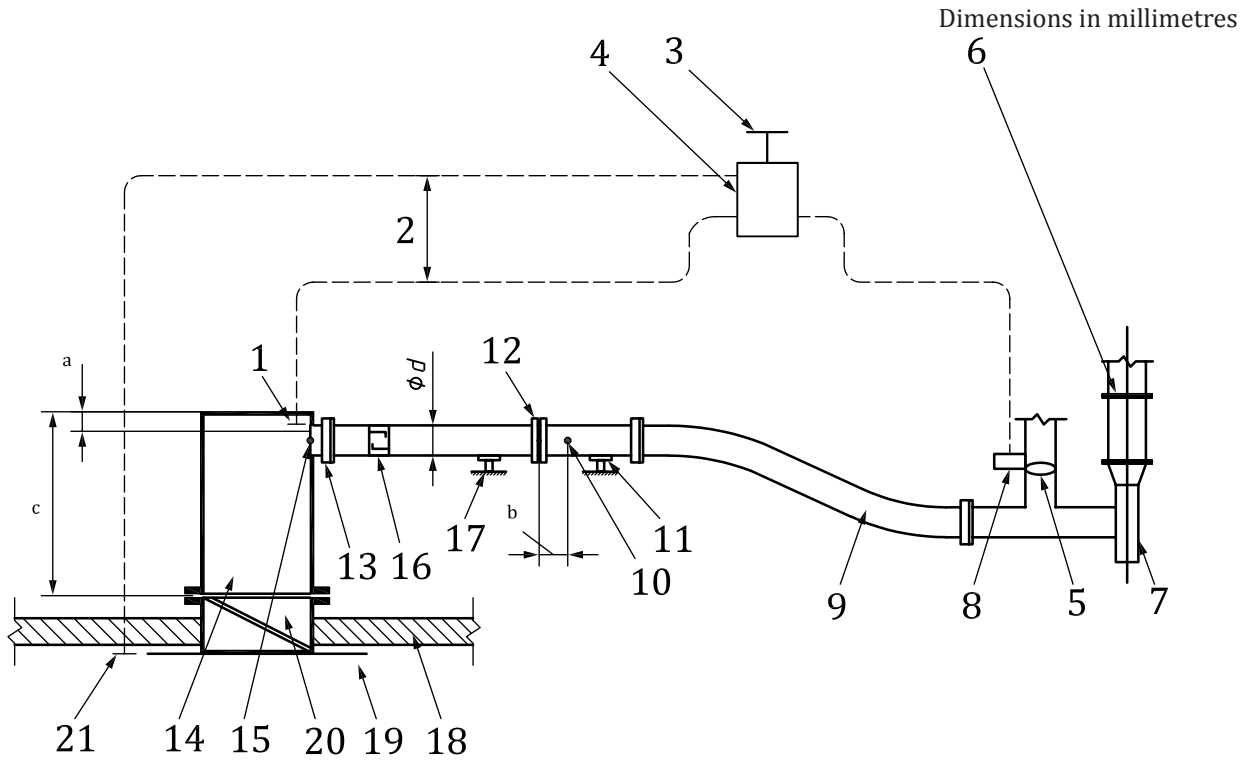

**Key**

- 1 pressure sensor
  - 2 pressure differential (300 Pa)
  - 3 pressure sensor in laboratory
  - 4 pressure differential control box
  - 5 pressure control dilution damper
  - 6 balancing damper
  - 7 fan
  - 8 pneumatic actuator or manual control
  - 9 flexible connecting duct
  - 10 thermocouple
  - 11 support
  - 12 orifice plate or venturi
  - 13 flange
  - 14 connecting duct
  - 15 thermocouple at exit from plenum
  - 16 flow straightener
  - 17 support
  - 18 supporting construction {floor}
  - 19 furnace chamber
  - 20 test damper
  - 21 pressure sensor
- a Dimension equal to the diameter of the measuring station.  
 b Distance from thermocouple to orifice plate = 2 x diameter of the measuring duct.  
 c 2 x diagonal dimension of the damper (to a maximum of 2 m).

**iTeh STANDARD PREVIEW**  
**(standards.iteh.ai)**

<https://standards.iteh.ai/catalog/standards/sist/17985c68-aad-4f20-8155-621f5fe6ebd9/iso-21925-2-2021>

**Figure 2 — Example of an alternative arrangement when testing dampers in floors**

Dimensions in millimetres

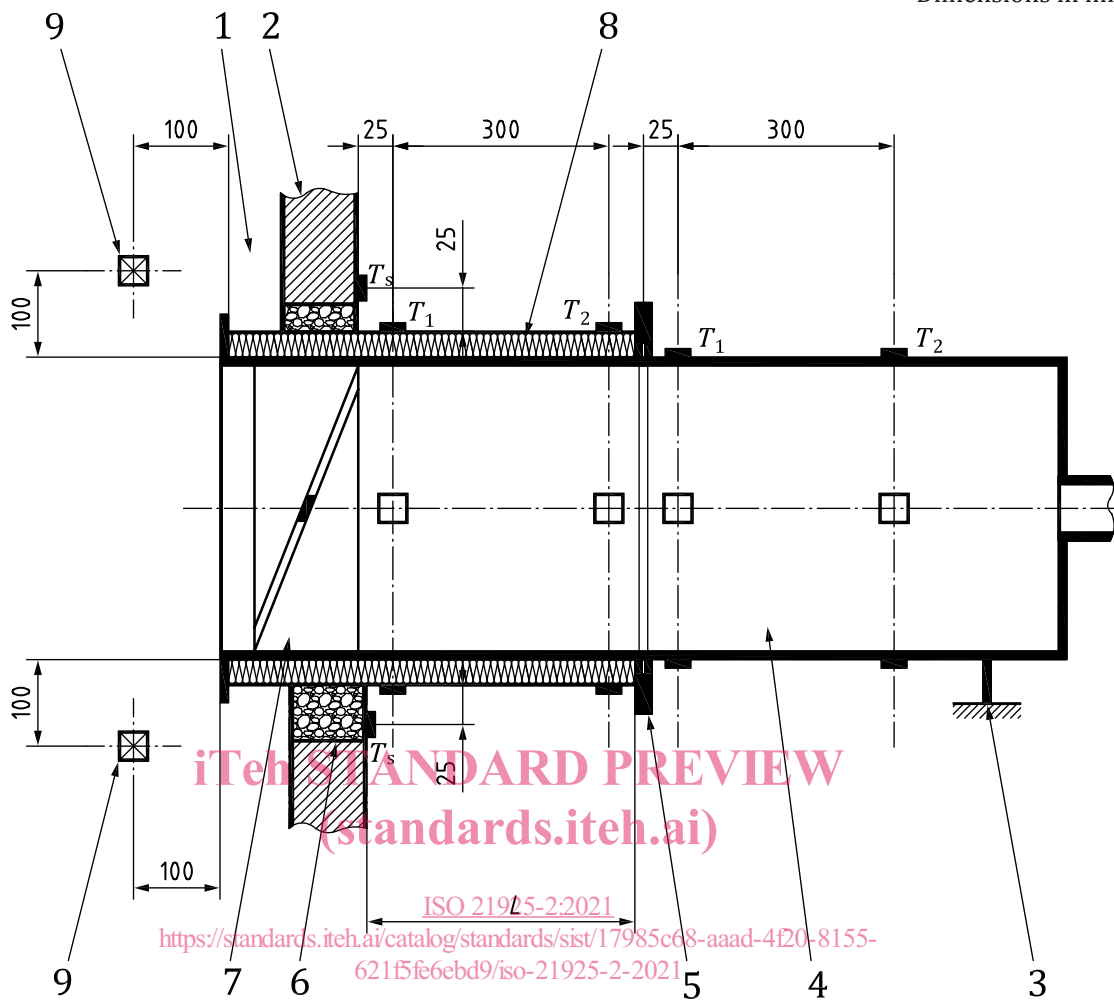

**Key**

- 1 furnace
- 2 supporting construction
- 3 support
- 4 connecting duct
- 5 connecting angle
- 6 infill material, provided it is necessary
- 7 test damper
- 8 insulated ductwork
- 9 furnace thermocouples, 4 places
- L* dimension to be specified by damper manufacturer
- T<sub>s</sub>* supporting construction unexposed surface thermocouples (minimum of one each side)
- T<sub>1</sub>, T<sub>2</sub>* unexposed surface thermocouples (minimum of one each side)

**Figure 3 — Position of surface thermocouples when damper is installed in an insulated duct**

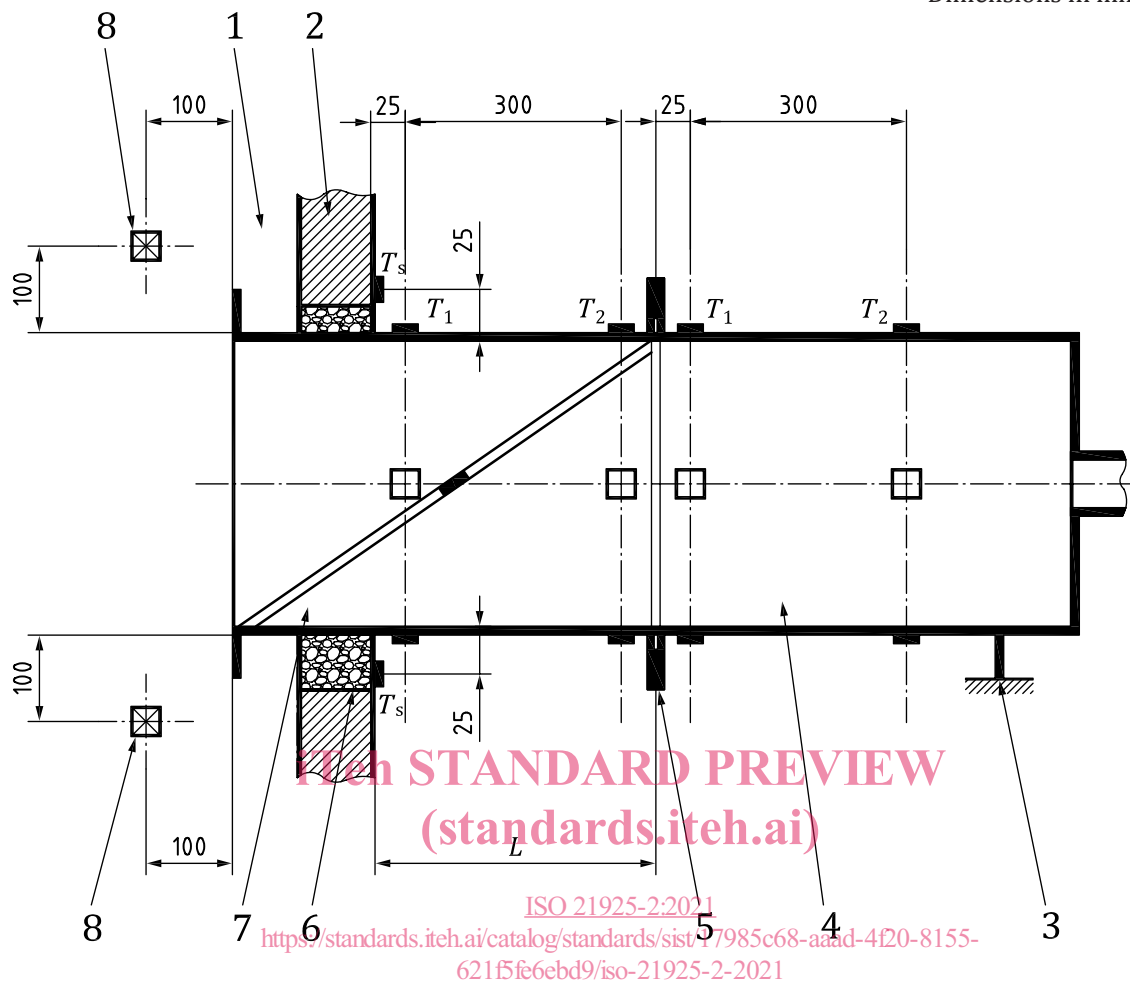

**Key**

- 1 furnace
- 2 supporting construction
- 3 support
- 4 connecting duct
- 5 connecting angle
- 6 infill material, provided it is necessary
- 7 test damper
- 8 furnace thermocouples, 4 places
- $L$  dimension to be specified by damper manufacturer
- $T_s$  supporting construction unexposed surface thermocouples (minimum of one each side)
- $T_1, T_2$  unexposed surface thermocouples (minimum of one each side)

**Figure 4 — Position of surface thermocouples when damper is installed in a non-insulated duct**

Dimensions in millimetres

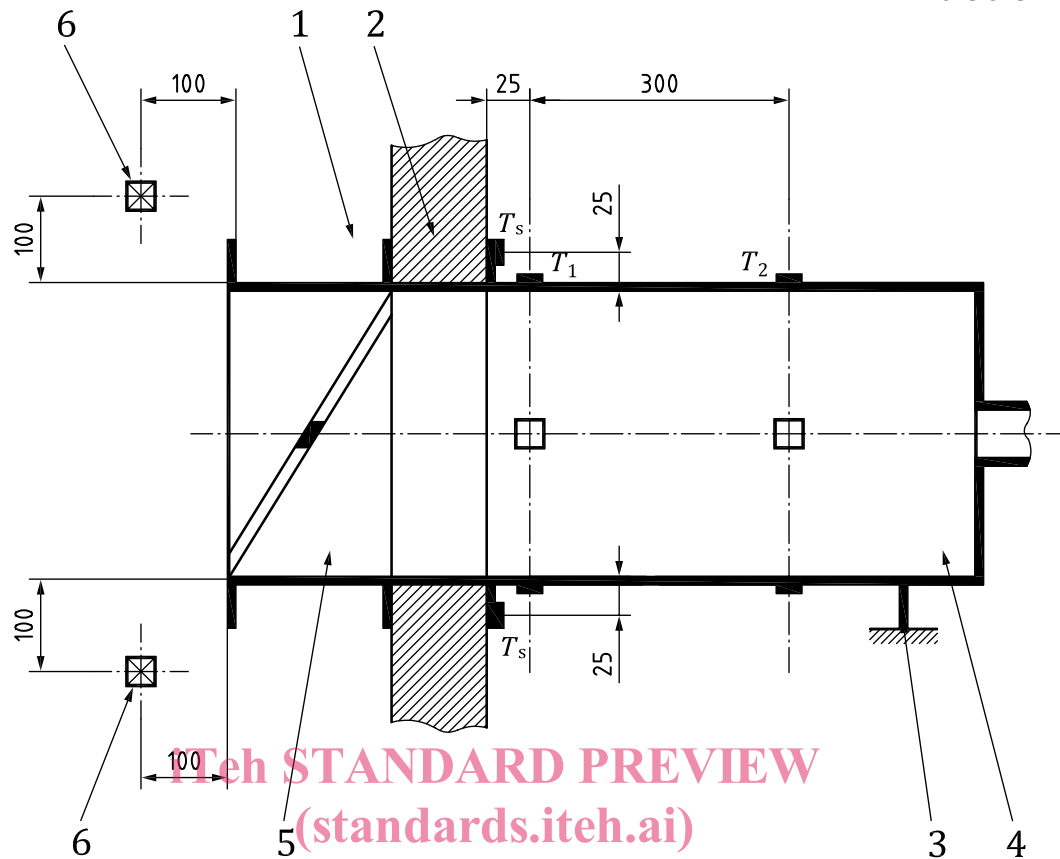
**Key**

- ISO 21925-2:2021
- 1 furnace <https://standards.iteh.ai/catalog/standards/sist/17985c68-aaad-4f20-8155-621f5fe6ebd9/iso-21925-2-2021>
- 2 supporting construction [621f5fe6ebd9/iso-21925-2-2021](https://standards.iteh.ai/catalog/standards/sist/17985c68-aaad-4f20-8155-621f5fe6ebd9/iso-21925-2-2021)
- 3 support
- 4 connecting duct
- 5 test damper
- 6 furnace thermocouples, 4 places
- $T_s$  supporting construction unexposed surface thermocouples (minimum of one each side)
- $T_1, T_2$  unexposed surface thermocouples (minimum of one each side)

**Figure 5 — Damper mounted onto face of supporting construction within the furnace**

Dimensions in millimetres

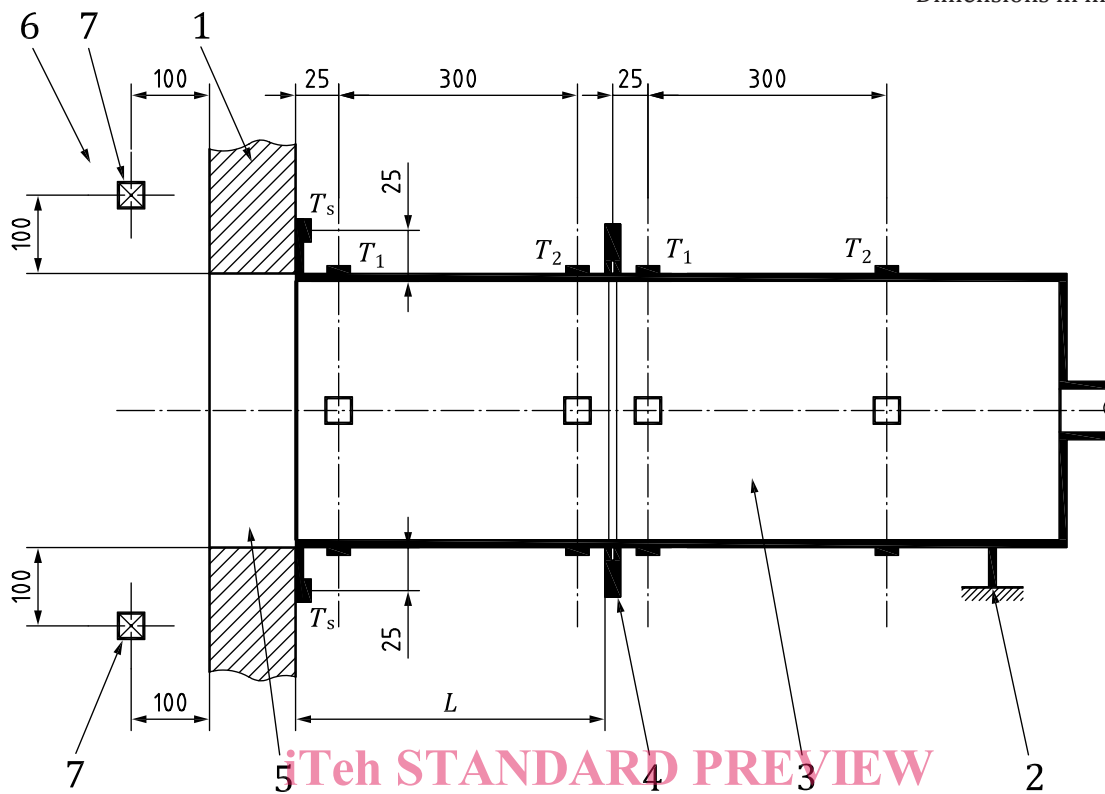

**Key**

- 1 supporting construction
- 2 support
- 3 connecting duct
- 4 test damper
- 5 connecting angle
- 6 furnace
- 7 furnace thermocouples, 4 places
- $L$  dimension to be specified by damper manufacturer
- $T_s$  supporting construction unexposed surface thermocouples (minimum of one each side)
- $T_1, T_2$  unexposed surface thermocouples (minimum of one each side)

Teh STANDARD PREVIEW  
(standards.iteh.ai)

[ISO 21925-2:2021](https://standards.iteh.ai/catalog/standards/sist/17985c68-aaad-4f20-8155-621f5fe6ebd9/iso-21925-2-2021)

<https://standards.iteh.ai/catalog/standards/sist/17985c68-aaad-4f20-8155-621f5fe6ebd9/iso-21925-2-2021>

**Figure 6 — Damper mounted onto face of supporting construction outside the furnace**

Dimensions in millimetres

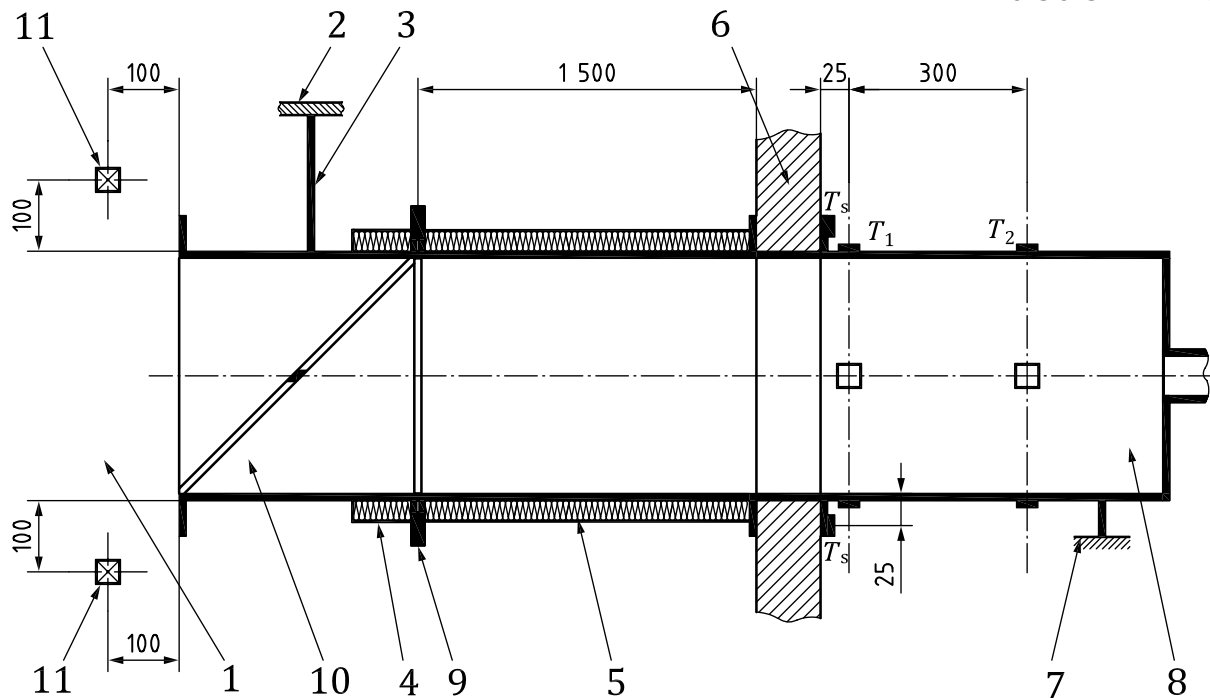

**Key**

- 1 furnace
- 2 floor, for example
- 3 suitable attachment as in practice
- 4 insulation, provided it is necessary
- 5 insulated duct
- 6 supporting construction
- 7 support
- 8 connecting duct
- 9 connecting angle
- 10 test damper
- 11 furnace thermocouples, 4 places
- $T_s$  supporting construction unexposed surface thermocouples (minimum of one each side)
- $T_1, T_2$  unexposed surface thermocouples (minimum of one each side)

**iTeh STANDARD PREVIEW**  
(standards.iteh.ai)

**Figure 7 — Damper mounted remote from the supporting construction and within the furnace chamber**