

FINAL  
DRAFT

INTERNATIONAL  
STANDARD

ISO/FDIS  
15245-1

ISO/TC 58/SC 2

Secretariat: AFNOR

Voting begins on:  
2021-02-18

Voting terminates on:  
2021-04-15

---

---

## Gas cylinders — Parallel threads for connection of valves to gas cylinders —

### Part 1: Specification

**iTeh STANDARD PREVIEW**  
*Bouteilles à gaz — Filetages parallèles pour le raccordement des robinets sur les bouteilles à gaz —*  
**(standards.iteh.ai)**  
*Partie 1: Spécification*

[ISO/FDIS 15245-1](#)

<https://standards.iteh.ai/catalog/standards/sist/2bff9941-00cb-46f7-8238-faf8bc654d5d/iso-fdis-15245-1>

RECIPIENTS OF THIS DRAFT ARE INVITED TO SUBMIT, WITH THEIR COMMENTS, NOTIFICATION OF ANY RELEVANT PATENT RIGHTS OF WHICH THEY ARE AWARE AND TO PROVIDE SUPPORTING DOCUMENTATION.

IN ADDITION TO THEIR EVALUATION AS BEING ACCEPTABLE FOR INDUSTRIAL, TECHNOLOGICAL, COMMERCIAL AND USER PURPOSES, DRAFT INTERNATIONAL STANDARDS MAY ON OCCASION HAVE TO BE CONSIDERED IN THE LIGHT OF THEIR POTENTIAL TO BECOME STANDARDS TO WHICH REFERENCE MAY BE MADE IN NATIONAL REGULATIONS.

**ISO/CEN PARALLEL PROCESSING**



Reference number  
ISO/FDIS 15245-1:2021(E)

© ISO 2021

**iTeh STANDARD PREVIEW**  
**(standards.iteh.ai)**

[ISO/FDIS 15245-1](https://standards.iteh.ai/catalog/standards/sist/2bff9941-00cb-46f7-8238-faf8bc654d5d/iso-fdis-15245-1)  
<https://standards.iteh.ai/catalog/standards/sist/2bff9941-00cb-46f7-8238-faf8bc654d5d/iso-fdis-15245-1>



**COPYRIGHT PROTECTED DOCUMENT**

© ISO 2021

All rights reserved. Unless otherwise specified, or required in the context of its implementation, no part of this publication may be reproduced or utilized otherwise in any form or by any means, electronic or mechanical, including photocopying, or posting on the internet or an intranet, without prior written permission. Permission can be requested from either ISO at the address below or ISO's member body in the country of the requester.

ISO copyright office  
CP 401 • Ch. de Blandonnet 8  
CH-1214 Vernier, Geneva  
Phone: +41 22 749 01 11  
Email: [copyright@iso.org](mailto:copyright@iso.org)  
Website: [www.iso.org](http://www.iso.org)

Published in Switzerland

# Contents

	Page
Foreword .....	iv
Introduction .....	v
<b>1 Scope</b> .....	<b>1</b>
<b>2 Normative references</b> .....	<b>1</b>
<b>3 Terms and definitions</b> .....	<b>1</b>
<b>4 Requirements</b> .....	<b>3</b>
4.1 Thread rotation .....	3
4.2 Thread profile .....	3
4.3 Pitch .....	4
4.4 Thread dimensions .....	6
4.5 O-rings .....	6
<b>5 Thread end finish</b> .....	<b>7</b>
<b>6 Marking</b> .....	<b>7</b>
<b>Bibliography</b> .....	<b>8</b>

## iTeh STANDARD PREVIEW (standards.iteh.ai)

[ISO/FDIS 15245-1](https://standards.iteh.ai/catalog/standards/sist/2bff9941-00cb-46f7-8238-faf8bc654d5d/iso-fdis-15245-1)

<https://standards.iteh.ai/catalog/standards/sist/2bff9941-00cb-46f7-8238-faf8bc654d5d/iso-fdis-15245-1>

## Foreword

ISO (the International Organization for Standardization) is a worldwide federation of national standards bodies (ISO member bodies). The work of preparing International Standards is normally carried out through ISO technical committees. Each member body interested in a subject for which a technical committee has been established has the right to be represented on that committee. International organizations, governmental and non-governmental, in liaison with ISO, also take part in the work. ISO collaborates closely with the International Electrotechnical Commission (IEC) on all matters of electrotechnical standardization.

The procedures used to develop this document and those intended for its further maintenance are described in the ISO/IEC Directives, Part 1. In particular, the different approval criteria needed for the different types of ISO documents should be noted. This document was drafted in accordance with the editorial rules of the ISO/IEC Directives, Part 2 (see [www.iso.org/directives](http://www.iso.org/directives)).

Attention is drawn to the possibility that some of the elements of this document may be the subject of patent rights. ISO shall not be held responsible for identifying any or all such patent rights. Details of any patent rights identified during the development of the document will be in the Introduction and/or on the ISO list of patent declarations received (see [www.iso.org/patents](http://www.iso.org/patents)).

Any trade name used in this document is information given for the convenience of users and does not constitute an endorsement.

For an explanation of the voluntary nature of standards, the meaning of ISO specific terms and expressions related to conformity assessment, as well as information about ISO's adherence to the World Trade Organization (WTO) principles in the Technical Barriers to Trade (TBT), see [www.iso.org/iso/foreword.html](http://www.iso.org/iso/foreword.html).

This document was prepared by Technical Committee ISO/TC 58, *Gas cylinders*, Subcommittee SC 2, *Cylinder fittings*, in collaboration with the European Committee for Standardization (CEN) Technical Committee CEN/TC 23, *Transportable gas cylinders*, in accordance with the Agreement on technical cooperation between ISO and CEN (Vienna Agreement).

This second edition cancels and replaces the first edition (ISO 15245-1:2001), which has been technically revised. It also incorporates the Amendment ISO 15245-1:2001/Amd.1:2013.

The main changes compared to the previous edition are as follows:

- modification of [Figure 2](#);
- addition of subclause [4.5](#);
- minor editorial changes throughout the document to fully align with ISO/IEC Directives Part 2.

A list of all parts in the ISO 15245 series can be found on the ISO website.

Any feedback or questions on this document should be directed to the user's national standards body. A complete listing of these bodies can be found at [www.iso.org/members.html](http://www.iso.org/members.html).

## Introduction

Cylinders intended to contain compressed, liquefied or dissolved gas under pressure are fitted with accessories (valves, straight or angle fittings) to allow release of and refilling with gas. In this document, the term “valve” applies to such accessories.

The connection between cylinder and valve is obtained by the assembly of two parallel threads with the same nominal pitch and thread profile – an external one on the valve stem and an internal one in the cylinder neck – and an O-ring seal.

## iTeh STANDARD PREVIEW (standards.iteh.ai)

[ISO/FDIS 15245-1](https://standards.iteh.ai/catalog/standards/sist/2bff9941-00cb-46f7-8238-faf8bc654d5d/iso-fdis-15245-1)

<https://standards.iteh.ai/catalog/standards/sist/2bff9941-00cb-46f7-8238-faf8bc654d5d/iso-fdis-15245-1>

**iTeh STANDARD PREVIEW**  
**(standards.iteh.ai)**

[ISO/FDIS 15245-1](#)

<https://standards.iteh.ai/catalog/standards/sist/2bff9941-00cb-46f7-8238-faf8bc654d5d/iso-fdis-15245-1>

# Gas cylinders — Parallel threads for connection of valves to gas cylinders —

## Part 1: Specification

### 1 Scope

This document specifies definitions, dimensions and tolerances of parallel screw threads of M30 x 2, M25 x 2 and M18 x 1,5, for the connection of valves to medical and industrial gas cylinders.

This document does not contain the connection requirements for:

- mechanical strength;
- gas tightness;
- capability of repeated assembly and dismounting operations (this aspect is covered in ISO 13341).

### 2 Normative references

The following documents are referred to in the text in such a way that some or all of their content constitutes requirements of this document. For dated references, only the edition cited applies. For undated references, the latest edition of the referenced document (including any amendments) applies.

ISO 724, *ISO general-purpose metric screw threads — Basic dimensions*

ISO 5408, *Screw threads — Vocabulary*

ISO 10286, *Gas cylinders — Terminology*

### 3 Terms and definitions

For the purposes of this document, the terms and definitions given in ISO 10286, ISO 5408 and the following apply.

ISO and IEC maintain terminological databases for use in standardization at the following addresses:

- ISO Online browsing platform: available at <https://www.iso.org/obp>
- IEC Electropedia: available at <http://www.electropedia.org/>

#### 3.1

##### valve stem

parallel sided end of valve body, with a thread formed on the external surface with a plain machined section close to the flange on the valve body for O-ring seating and seal

Note 1 to entry: See [Figure 1](#), thread X.

**3.2  
cylinder neck thread**

A

parallel sided axial threaded hole in the cylinder neck

Note 1 to entry: See [Figure 2](#).

Note 2 to entry: This includes a thread formed on the internal surface including a sealing recess for the O-ring and thread relief.

**3.3  
sealing recess diameter**

B

diameter of tapered recess machined in the top face of the cylinder neck, concentric with the *cylinder neck thread* ([3.2](#)), to provide a surface on which the O-ring can seal

Note 1 to entry: See [Figure 2](#).

**3.4  
sealing recess depth**

F

depth of tapered recess machined in the top face of the cylinder neck, concentric with the *cylinder neck thread* ([3.2](#)), to provide a surface on which the O-ring can seal

Note 1 to entry: See [Figure 2](#).

**3.5  
thread relief diameter**

C

diameter of plain machined parallel sided section, concentric with the *cylinder neck thread* ([3.2](#)), between the cylinder neck thread and the [sealing recess](#) ([3.3](#))

Note 1 to entry: See [Figure 2](#).

iTeh STANDARD PREVIEW  
(standards.iteh.ai)

<https://standards.iteh.ai/catalog/standards/sist/2bff9941-00cb-46f7-8238-faf8bc654d5d/iso-fdis-15245-1>

**3.6  
distance to start of thread**

E

distance from the top face of the cylinder neck to the start of the thread, including recess depth and *thread relief length* ([3.7](#))

Note 1 to entry: See [Figure 2](#).

**3.7  
thread relief length**

V

minimum length of plain machined parallel sided section on the *valve stem* ([3.1](#)), between the valve stem thread and the flange on the valve body, on to which the O-ring can seal

Note 1 to entry: See [Figure 1](#).

**3.8  
minimum full thread length**

D

minimum distance from the top face of the cylinder neck to the bottom of the *cylinder neck thread* ([3.2](#))

Note 1 to entry: See [Figure 2](#).



**3.9****O-ring diameter***R*

internal diameter of seal used to prevent unintentional escape of gas from the cylinder

Note 1 to entry: See [Figure 3](#).

**3.10****O-ring thickness***W*

diameter of seal cross section used to prevent unintentional escape of gas from the cylinder

Note 1 to entry: See [Figure 3](#).

**3.11****flange diameter***Y*

minimum diameter of the flange on the valve body which seals on to the O-ring and the top face of the cylinder neck

Note 1 to entry: See [Figure 1](#).

**3.12****length of valve stem***Z*

distance from the flange on the valve body to the bottom of the *valve stem* (3.1) thread

Note 1 to entry: See [Figure 1](#).

**3.13****vent groove***G*

groove(s) which are machined in the *valve stem* (3.1) thread such that any residual pressure within the cylinder will be vented when the valve is unscrewed

Note 1 to entry: See [Figure 4](#).

Note 2 to entry: Such grooves need to have smooth edges in order to ensure that they do not damage the cylinder threads during insertion or removal of valves.

**4 Requirements****4.1 Thread rotation**

The thread shall be a right-hand thread such that it moves away from an observer when rotated clockwise.

**4.2 Thread profile**

The thread profile is standard ISO form (see ISO 68-1) with a 60° angle. The form and thread height measurements are perpendicular to the axis of the thread.

### 4.3 Pitch

The pitches are as follows:

- M18: 1,5 mm (see ISO 724);
- M25: 2 mm (see ISO 724);
- M30: 2 mm (see ISO 724).

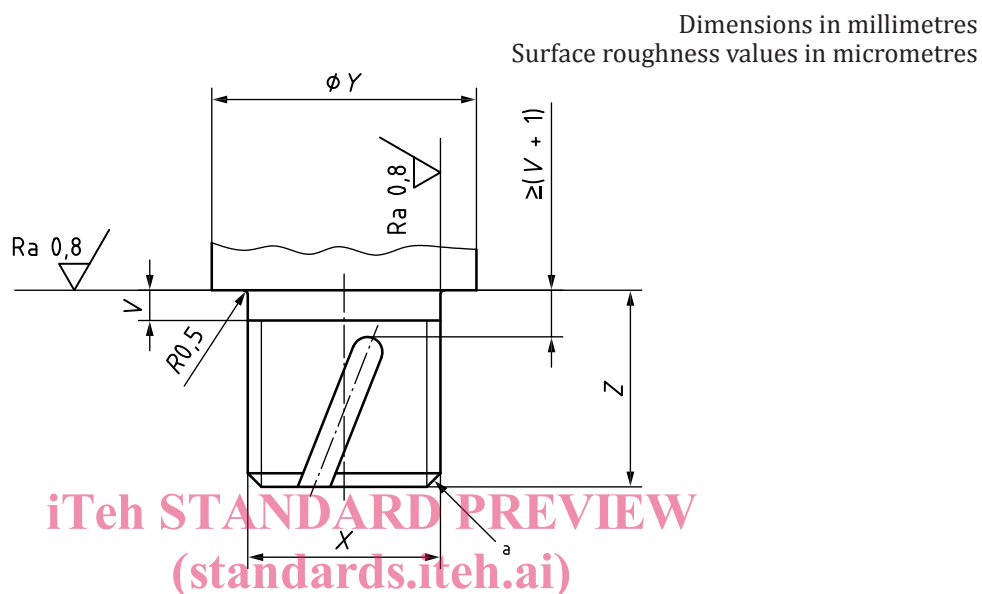

#### Key

<sup>a</sup> Chamfer 45° x root diameter or radius of 4 mm (M18 x 1,5) or 5 mm (M25 x 2,0 and M30 x 2,0).

If a chamfer option is preferred, ensure the form of the first thread is not sharp.

**Figure 1 — Valve body stem**