**Aerospace — Lead and runout
threads —**

**Part 2:
Internal threads**

Aéronautique et espace — Filets incomplets, débuts et fins de filets —

Partie 2: Filetages intérieurs

iTeh STANDARD PREVIEW
(standards.iteh.ai)

ISO 3353-2:2020

<https://standards.iteh.ai/catalog/standards/sist/5a177738-312a-48ea-b628-99a13d1b2956/iso-3353-2-2020>



iTeh STANDARD PREVIEW
(standards.iteh.ai)

ISO 3353-2:2020

<https://standards.iteh.ai/catalog/standards/sist/5a177738-312a-48ea-b628-99a13d1b2956/iso-3353-2-2020>



COPYRIGHT PROTECTED DOCUMENT

© ISO 2020

All rights reserved. Unless otherwise specified, or required in the context of its implementation, no part of this publication may be reproduced or utilized otherwise in any form or by any means, electronic or mechanical, including photocopying, or posting on the internet or an intranet, without prior written permission. Permission can be requested from either ISO at the address below or ISO's member body in the country of the requester.

ISO copyright office
CP 401 • Ch. de Blandonnet 8
CH-1214 Vernier, Geneva
Phone: +41 22 749 01 11
Email: copyright@iso.org
Website: www.iso.org

Published in Switzerland

Contents

	Page
Foreword	iv
1 Scope	1
2 Normative references	1
3 Terms and definitions	1
4 Symbols for threads	2
5 Requirements	2
5.1 General requirements	2
5.2 Lead threads	3
5.3 Runouts	4
5.4 Undercuts	5

iTeh STANDARD PREVIEW (standards.iteh.ai)

ISO 3353-2:2020

<https://standards.iteh.ai/catalog/standards/sist/5a177738-312a-48ea-b628-99a13d1b2956/iso-3353-2-2020>

Foreword

ISO (the International Organization for Standardization) is a worldwide federation of national standards bodies (ISO member bodies). The work of preparing International Standards is normally carried out through ISO technical committees. Each member body interested in a subject for which a technical committee has been established has the right to be represented on that committee. International organizations, governmental and non-governmental, in liaison with ISO, also take part in the work. ISO collaborates closely with the International Electrotechnical Commission (IEC) on all matters of electrotechnical standardization.

The procedures used to develop this document and those intended for its further maintenance are described in the ISO/IEC Directives, Part 1. In particular, the different approval criteria needed for the different types of ISO documents should be noted. This document was drafted in accordance with the editorial rules of the ISO/IEC Directives, Part 2 (see www.iso.org/directives).

Attention is drawn to the possibility that some of the elements of this document may be the subject of patent rights. ISO shall not be held responsible for identifying any or all such patent rights. Details of any patent rights identified during the development of the document will be in the Introduction and/or on the ISO list of patent declarations received (see www.iso.org/patents).

Any trade name used in this document is information given for the convenience of users and does not constitute an endorsement.

For an explanation of the voluntary nature of standards, the meaning of ISO specific terms and expressions related to conformity assessment, as well as information about ISO's adherence to the World Trade Organization (WTO) principles in the Technical Barriers to Trade (TBT), see www.iso.org/iso/foreword.html.

This document was prepared by Technical Committee ISO/TC 20, *Aircraft and space vehicles* Subcommittee SC 4, *Aerospace fastener systems*. [ISO 3353-2:2020](https://standards.iteh.ai/catalog/standards/sist/5a177738-312a-48ea-b628-)
<https://standards.iteh.ai/catalog/standards/sist/5a177738-312a-48ea-b628->

This second edition cancels and replaces the first edition (ISO 3353-2:2002), of which it constitutes a minor revision.

The main changes compared to the previous edition are as follows:

- update of the term “lead threads”;
- editorially revised.

A list of all parts in the ISO 3353 series can be found on the ISO website.

Any feedback or questions on this document should be directed to the user's national standards body. A complete listing of these bodies can be found at www.iso.org/members.html.

Aerospace — Lead and runout threads —

Part 2: Internal threads

1 Scope

This document specifies the lead and runout thread and undercut requirements for internal threads (blind tapped holes) for aerospace construction.

It is applicable whenever it is referenced in a definition document.

2 Normative references

The following documents are referred to in the text in such a way that some or all of their content constitutes requirements of this document. For dated references, only the edition cited applies. For undated references, the latest edition of the referenced document (including any amendments) applies.

ISO 5855-1, *Aerospace — MJ threads — Part 1: General requirements*

3 Terms and definitions (standards.iteh.ai)

For the purposes of this document, the following terms and definitions apply.

ISO and IEC maintain terminological databases for use in standardization at the following addresses:

- ISO Online browsing platform: available at <https://www.iso.org/obp>
- IEC Electropedia: available at <http://www.electropedia.org/>

3.1

lead thread

portion of the incomplete thread that is fully formed at the root but not at the crest which occurs at the beginning end of either an external or internal thread

3.2

runout thread

part of the screw thread in which is located the thread incompletely formed during cutting, between the completely formed threads and the end of the cylindrical part of the blind tapped hole

3.3

undercut

groove dug at the hole bottom to limit the threads with completely formed thread (except at the crossing between the last thread and the groove flank)

3.4

completely formed thread

thread, the profile of which (ABC) is located, over an axial distance of $1P$, within the limits specified in the definition document for the thread

Note 1 to entry: See [Figure 1](#).

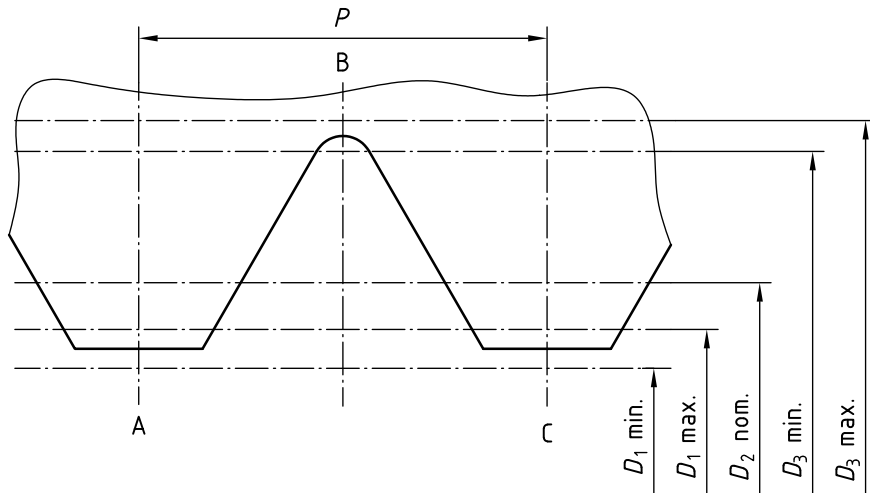

Figure 1 — Completely formed thread

4 Symbols for threads

D_1 the minor diameter of the thread

D_2 the pitch diameter of the thread

D_3 the major diameter of the thread

P the thread pitch

iTech STANDARD PREVIEW
(standards.iteh.ai)

[ISO 3353-2:2020](https://standards.iteh.ai/catalog/standards/sist/5a177738-312a-48ea-b628-99a13d1b2956/iso-3353-2-2020)

<https://standards.iteh.ai/catalog/standards/sist/5a177738-312a-48ea-b628-99a13d1b2956/iso-3353-2-2020>

5 Requirements

5.1 General requirements

The flanks at the root of the incompletely formed threads shall be joined by a radius or by two radii and a flat, that are smooth and devoid of abrupt tool marks not compatible with respect to the roughness specified in the product standard. This radius, or these radii shall be greater than or equal to the calculated radius of the root of the maximum profile specified ISO 5855-1 (diameter D_3 max.).

5.2 Lead threads

See [Figure 2](#).

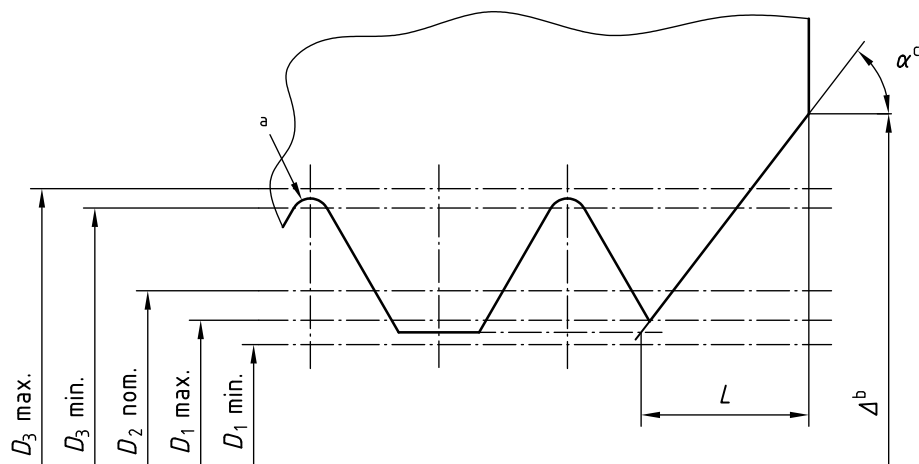

a Crest of first completely formed thread.

b

$$\Delta = D_3 \text{ max. } \begin{matrix} +0,6 \\ 0 \end{matrix}, \text{ for } D - 5 \text{ mm.}$$

$$\Delta = D_3 \text{ max. } \begin{matrix} +0,8 \\ 0 \end{matrix}, \text{ for } D > 5 \text{ mm.}$$

c $45^\circ - \alpha - 60^\circ$.

ITIH STANDARD PREVIEW
(standards.iteh.ai)

NOTE The length L corresponds to the length of the lead threads. It results from the intersection of the entering countersunk and of the minor diameter of the thread D_1 .

<https://standards.iteh.ai/catalog/standards/sist/5a177738-312a-48ea-b628-99a1611b3952/iso-3353-2-2020>

ISO 3353-2:2020
Figure 2 — Lead threads

5.3 Runouts

See [Figure 3](#).

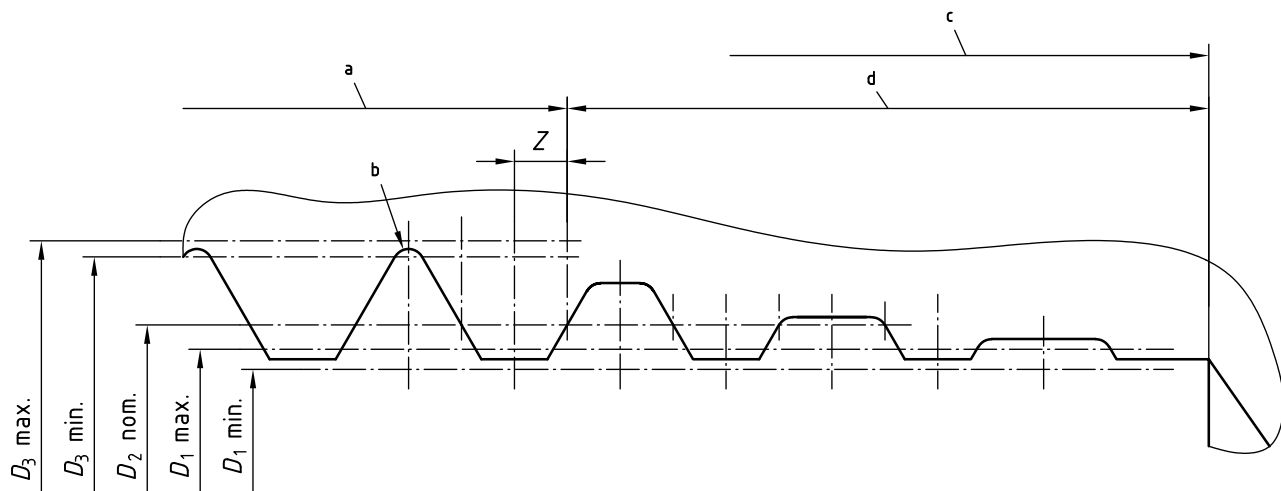

Over the area Z, the thread shall lie within the limits specified in the definition document for the thread.

- a Required minimum full thread depth as specified on the product standard or drawing.
- b Crest of first completely formed thread.
- c Maximum hole depth as permitted by the product standard or drawing.
- d Thread runout $-10P$.

ISO 3353-2:2020
<https://standards.iteh.ai/catalog/standards/sist/177738-312a-48ea-b628-99a13d1b2956/iso-3353-2-2020>
Figure 3 — Runouts

5.4 Undercuts

See [Figure 4](#).

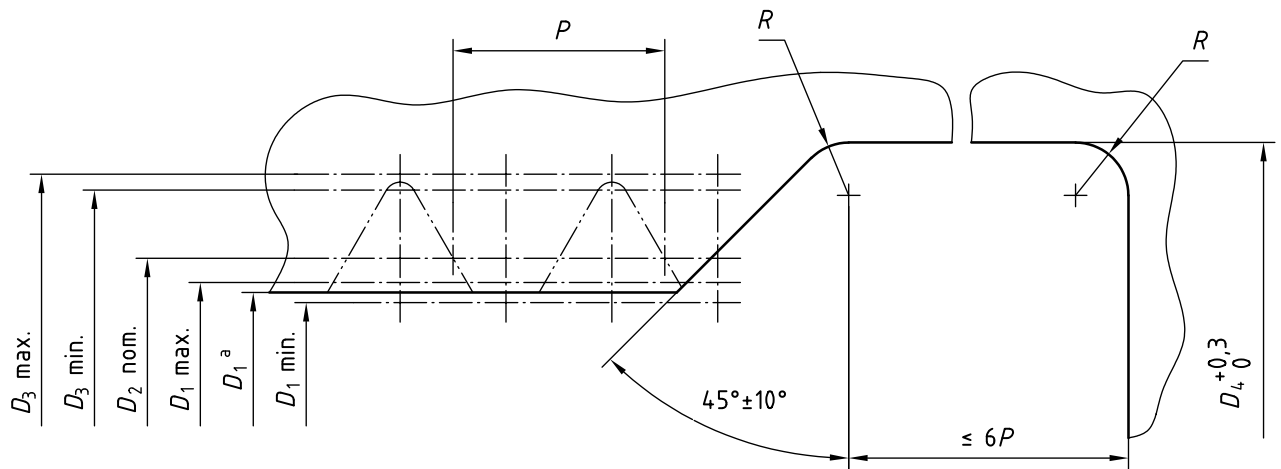

$$0,25P - R - 0,5P$$

$$D_4 = D_3 \text{ max.} + 0,3 \text{ mm for } P - 0,8 \text{ mm}$$

$$D_4 = D_3 \text{ max.} + 0,5 \text{ mm for } P > 0,8 \text{ mm}$$

iTeh STANDARD PREVIEW
(standards.iteh.ai)

^a Actual.

Figure 4 — Undercuts

ISO 3353-2:2020

<https://standards.iteh.ai/catalog/standards/sist/5a177738-312a-48ea-b628-99a13d1b2956/iso-3353-2-2020>