

Date: ~~2022-11-16~~ 2023-02-21

ISO 5718-2: ~~2022~~ 2023 (E)

ISO/TC 23/SC 7

Secretariat: ~~UNI~~

**Harvesting equipment — Requirements for cutting elements — Part 2: Blades
used on large rotary mowers**

*Matériel de récolte — Exigences relatives aux éléments coupants — Partie 2: Lames pour
grandes tondeuses rotatives*

iTeh STANDARD PREVIEW
(standards.iteh.ai)

ISO/PRF 5718-2

<https://standards.iteh.ai/catalog/standards/sist/f546026d-cf44-4f74-967f-875587cd35b9/iso-prf-5718-2>

~~COPYRIGHT PROTECTED DOCUMENT~~

~~© ISO 2023~~

All rights reserved. Unless otherwise specified, or required in the context of its implementation, no part of this publication may be reproduced or utilized otherwise in any form or by any means, electronic or mechanical, including photocopying, or posting on the internet or an intranet, without prior written permission. Permission can be requested from either ISO at the address below or ~~ISO's~~ISO's member body in the country of the requester.

~~ISO copyright office~~Copyright Office
~~Ch. de Blandonnet 8~~ • CP 401

~~•~~ CH-1214 Vernier, Geneva, ~~Switzerland~~
~~Tel. Phone:~~ + 41 22 749 01 11
~~Fax~~ + 41 22 749 09 47

~~copyright@iso.org~~

~~www.iso.org~~

~~Email:~~ copyright@iso.org

~~Website:~~ www.iso.org

~~Published in Switzerland.~~

~~ITeH STANDARD PREVIEW~~
(standards.iteh.ai)

ISO/PRF 5718-2

<https://standards.iteh.ai/catalog/standards/sist/f546026d-cf44-4f74-967f-875587cd35b9/iso-prf-5718-2>

Contents

Foreword	iv
Introduction	vi
1 Scope	1
2 Normative reference(s)	1
3 Terms and definitions	1
4 Requirements	2
4.1 Material requirements	2
4.2 Test procedures	3
4.2.1 Charpy impact strength test	3
4.2.2 Bend test	3
5 Marking and documentation	7
5.1 Marking	7
5.2 Documentation	7
Bibliography	8
Foreword	iv
Introduction	vi
1 Scope	1
2 Normative reference(s)	1
3 Terms and definitions	1
4 Requirements	2
4.1 Material requirements	2
4.2 Test procedures	3
4.2.1 Charpy impact strength test	3
4.2.2 Bend test	3
5 Marking and documentation	7
5.1 Marking	7
5.2 Documentation	7
Bibliography	8

Foreword

ISO (the International Organization for Standardization) is a worldwide federation of national standards bodies (ISO member bodies). The work of preparing International Standards is normally carried out through ISO technical committees. Each member body interested in a subject for which a technical committee has been established has the right to be represented on that committee. International organizations, governmental and non-governmental, in liaison with ISO, also take part in the work. ISO collaborates closely with the International Electrotechnical Commission (IEC) on all matters of electrotechnical standardization.

The procedures used to develop this document and those intended for its further maintenance are described in the ISO/IEC Directives, Part 1. In particular, the different approval criteria needed for the different types of ISO documents should be noted. This document was drafted in accordance with the editorial rules of the ISO/IEC Directives, Part 2 (see www.iso.org/directives).

Attention is drawn to the possibility that some of the elements of this document may be the subject of patent rights. ISO shall not be held responsible for identifying any or all such patent rights. Details of any patent rights identified during the development of the document will be in the Introduction and/or on the ISO list of patent declarations received (see www.iso.org/patents).

Any trade name used in this document is information given for the convenience of users and does not constitute an endorsement.

For an explanation of the voluntary nature of standards, the meaning of ISO specific terms and expressions related to conformity assessment, as well as information about ISO's adherence to the World Trade Organization (WTO) principles in the Technical Barriers to Trade (TBT), see www.iso.org/iso/foreword.html.

This document was prepared by Technical Committee ISO/TC 23, *Tractors and machinery for agriculture and forestry*, Subcommittee SC 7, *Equipment for harvesting and conservation*.

This first edition of ISO 5718-2, together with ISO 5718-1, cancels and replaces ~~ISO 5718:2013~~, which has been technically revised. It also incorporates the Amendment ISO 5718:~~2013~~Amd 1:2019.

The main changes ~~compared to the previous edition~~ are as follows:

- In Clause ~~1~~:
 - ~~additional information has been added to the Scope regarding applicability;~~
- In Clause ~~2~~:
 - ~~the normative references has been updated;~~
- In Clause 3:
 - some terms and definitions have been modified, added or removed;
 - former ~~figure~~Figure 1 has been removed;
 - former ~~figure~~Figure 2 has been removed;

- In Clause 4:
 - the test procedure requirements have been modified to address large rotary mowers;
 - an alternate test fixture and procedure for the blade test has been added;
 - all former figures has been removed and/or replaced to address large rotary mowers;
- Bibliography has been added;
- ~~Document has been editorially revised.~~

A list of all parts in the ISO 5718 series can be found on the ISO website.

Any feedback or questions on this document should be directed to the user's national standards body. A complete listing of these bodies can be found at www.iso.org/members.html.

iTeh STANDARD PREVIEW
(standards.iteh.ai)

<https://standards.iteh.ai/catalog/standards/sist/f546026d-cf44-4f74-967f-875587cd35b9/iso-prf-5718-2>

Introduction

There are a variety of cutting elements that can be used on large rotary mowers. This document provides specific requirements for blades.

iTeh STANDARD PREVIEW
(standards.iteh.ai)

ISO/PRF 5718-2

<https://standards.iteh.ai/catalog/standards/sist/f546026d-cf44-4f74-967f-875587cd35b9/iso-prf-5718-2>

Harvesting equipment — Requirements for cutting elements — Part 2: Blades used on large rotary mowers

1 Scope

This document specifies requirements for blades used as cutting elements on large rotary mowers (as defined in ISO 4254-13) for shredding crop residue, grass and small brush by impact.

It specifies requirements for testing and marking of such blades.

This document is not applicable to blades used on:

- rotary disc mowers, rotary drum mowers, and flail mowers designed for forage crop harvesting as covered by ISO 4254-12;
- arm-type large rotary mowers;
- pedestrian-controlled motor mowers;
- lawn mowers covered by [the ISO 5395 \(all parts\) series](#).

NOTE 1 The main purpose of this document is to set material characteristics. Blades on large rotary mowers are exposed to considerable centripetal forces and impacts with foreign objects. A bend test and Charpy impact test to check the brittleness and toughness of the material is therefore included in this document.

NOTE 2 This document does not specify dimensional requirements.

2 Normative reference(s)

The following documents are referred to in the text in such a way that some or all of their content constitutes requirements of this document. For dated references, only the cited applies. For undated references, the latest edition of the references document (including any amendments) applies.

ISO 148-1, *Metallic materials — Charpy pendulum impact test — Part 1: Test method*

ISO 3785, *Metallic materials — Designation of test specimen axes in relation to product texture*

ISO 6508-1, *Metallic materials — Rockwell hardness test — Part 1: Test method (scales A, B, C, D, E, F, G, H, K, N, T)*

3 Terms and definitions

For the purpose of this document **International Standard**, the following terms and definitions apply.

ISO and IEC maintain terminological databases for use in standardization at the following addresses:

- ISO Online Browsing Platform: available at <https://www.iso.org/obp>
- IEC Electropedia: available at <http://www.electropedia.org/>

3.1

blade

pivoting element, which may be flat, twisted, wrenched or otherwise formed, that performs the shredding of the crop residue, grass and small brush

3.2

blade lot

quantity of *blades* (3.1), as determined by the blade manufacturer, which is traceable to a single *heat of steel* (3.3) and *manufacturing process* (3.4)

3.3

heat of steel

mill heat

metal produced by a single cycle of a batch-melting process

Note 1 to entry:—The heat analysis is obtained from a small sample of molten metal from the ladle or furnace. The sample is allowed to solidify, then, a spectrochemical analysis is performed. If the chemical analysis is within specification, the balance of molten metal can be cast as one heat treat number. Typically, heats are over 50-t with many mills running heats about 300-t.

3.4

manufacturing process

series of thermal operations applied to the steel material to transform it into a finished *blade* (3.1)

Note 1 to entry:—Examples include: heating the material for forming purposes, heat treatment operation.

3.5

permanent set angle

angle formed by the back of the cutting element or *test coupon* (3.7) in the area of the bend after removal from the cutting-element bend-test fixture

Note 1 to entry: See Figure-1.

3.6

total deflection angle

sum of the permanent set angle and the estimated spring back

Note 1 to entry: This angle is for ease of fixture design and not acceptance criteria. (See Table-1.)

3.7

test coupon

flat specimen with the same cross-section and of the same *blade lot* (3.2) as the *blade* (3.1) it represents

3.8

visible crack

linear discontinuity in the material that is visible by the naked eye

4 Requirements

4.1 Material requirements

Blades shall be made of steel chosen by the manufacturer. The values of Rockwell hardness shall be at least 38-HRC, in accordance with ISO-6508-1. The degree of brittleness shall meet the requirements of 4.2.

4.2 Test procedures

4.2.1 Charpy impact strength test

4.2.1.1 Test procedure

The following test procedures shall be followed.

- a) Determine the Charpy impact strength for the lot after heat treatment₂.
- b) Conduct the Charpy impact testing in accordance with ISO 148-1 methods₂.
- c) Test three specimens from one blade or test coupon for each heat of steel₂.
- d) Arrange specimens using the X-Y orientation as defined in ISO 3785.

NoteNOTE The test can be performed on the sample blade or test coupon after the bend test.

4.2.1.2 Acceptance criteria

If any test blade or test coupon from a heat of steel does not have an average Charpy value of 20,3-joules or greater, the entire lot shall be totally rejected and blades from that lot cannot be used without corrective measures.

4.2.1.3 Corrective measures

If a corrective measure such as annealing or reheat treating is performed on the blade lot, the blade lot shall then be retested. If all sample blades pass the retest, then the lot is accepted.

4.2.2 Bend test

4.2.2.1 Sampling

Random samples shall be selected from each blade lot at a minimum rate of one blade for each 200-blades, but not less than two blades from any one blade lot.

4.2.2.2 Test fixture

The test fixture:

- a) shall be constructed according to the fixture specified in Figure-2 (except as noted in 4.2.2.4) using the ram diameter selected from Table-1 based on the thickness of the blade in the area to be bent;
- b) may use stops on the ram which will stop against the roller area of the bottom die, but not make contact in the area of the bend in the blade, and if used, shall be positioned to provide the minimum permanent set angle per Table-1.

NOTE Suggested stop angles (total deflection angles) are specified in Table-1.

4.2.2.3 Blade bend test procedure

The following test procedure shall be followed.

- a) All parts are to be placed flat on the bend test die and bent at least enough to give the permanent set, total included angle over a time period not to exceed 15-seconds_s and at a maximum temperature of 49-°C (120-°F).
- b) The blade area placed between the support points in the die shall not be in a fin area, near a mounting hole or in an area of other bends or distortions. If this is not possible due to blade geometry, use test coupon.

c) When the beginning of a crack or break is indicated, stop the test and remove the blade.

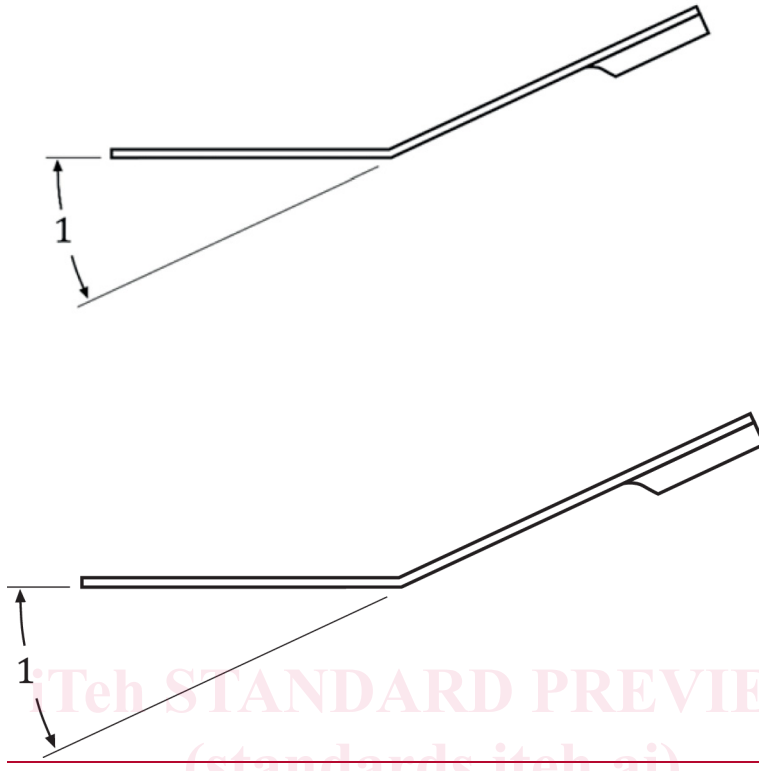

Key
1 permanent set angle

Figure 1 — Permanent set angle of blade after test

4.2.2.4 Alternate procedure

The following alternate procedure may be utilized.

- a) The objective of this test fixture and procedure is to produce 14,5% permanent elongation in the surface of the metal all the way across the blade.
- b) This is based on the assumption that the neutral axis of the blade is located in from the inside bend surface a distance equal to 40% of the thickness.
- c) Any other form of blade bend test fixture and procedure may be substituted as long as this objective is achieved.

4.2.2.5 Acceptance criteria

If any blade or test coupon from a blade lot breaks or incurs a visible crack before reaching the permanent set angle specified in Table-1, that entire blade lot shall be rejected, and blades from that blade lot shall not be used without corrective measures.

Table 1 — Blade bend angles

Blade material thickness (mm)	Ram diameter ±1 (mm)	Minimum permanent set angle (degrees)	Approximate total deflection angle (degrees)
-------------------------------	----------------------	---------------------------------------	--