

---

---

**Fine bubble technology —  
Environmental applications —**

**Part 1:  
Inspection method using online  
particle counter in dissolved air  
flotation (DAF) plant**

iTeh STANDARD PREVIEW  
(standards.iteh.ai)

[ISO/TS 4240-1:2023](https://standards.iteh.ai/catalog/standards/sist/80ea0475-e0e1-4dee-a9c9-9680009ce941/iso-ts-4240-1-2023)

<https://standards.iteh.ai/catalog/standards/sist/80ea0475-e0e1-4dee-a9c9-9680009ce941/iso-ts-4240-1-2023>



iTeh STANDARD PREVIEW  
(standards.iteh.ai)

ISO/TS 4240-1:2023

<https://standards.iteh.ai/catalog/standards/sist/80ea0475-e0e1-4dee-a9c9-9680009ce941/iso-ts-4240-1-2023>



**COPYRIGHT PROTECTED DOCUMENT**

© ISO 2023

All rights reserved. Unless otherwise specified, or required in the context of its implementation, no part of this publication may be reproduced or utilized otherwise in any form or by any means, electronic or mechanical, including photocopying, or posting on the internet or an intranet, without prior written permission. Permission can be requested from either ISO at the address below or ISO's member body in the country of the requester.

ISO copyright office  
CP 401 • Ch. de Blandonnet 8  
CH-1214 Vernier, Geneva  
Phone: +41 22 749 01 11  
Email: [copyright@iso.org](mailto:copyright@iso.org)  
Website: [www.iso.org](http://www.iso.org)

Published in Switzerland

# Contents

	Page
Foreword.....	iv
Introduction.....	v
<b>1 Scope.....</b>	<b>1</b>
<b>2 Normative references.....</b>	<b>1</b>
<b>3 Terms and definitions.....</b>	<b>1</b>
<b>4 Principle.....</b>	<b>2</b>
<b>5 BVC measurement technique.....</b>	<b>2</b>
5.1 Test equipment.....	2
5.2 Procedure.....	3
<b>6 Bubble bed depth measurement technique.....</b>	<b>4</b>
6.1 Test equipment.....	4
6.2 Procedure.....	5
<b>7 Advantages and limitations.....</b>	<b>6</b>
7.1 Advantages.....	6
7.2 Limitations.....	7
<b>Annex A (informative) Measurement of bubble size and size distribution by PCM.....</b>	<b>8</b>
<b>Annex B (informative) Height from the water surface to the bubble bed depth.....</b>	<b>9</b>
<b>Annex C (informative) Comparison of the results of bubble bed depth obtained by using the naked eye and by using a particle counting method.....</b>	<b>10</b>
<b>Annex D (informative) Measuring bubble bed depth of DAF process in full scale.....</b>	<b>12</b>
<b>Annex E (informative) Change of bubble bed depth at different operating conditions.....</b>	<b>14</b>
<b>Annex F (informative) Contribution of particles and bubbles in particle count measurements.....</b>	<b>15</b>
<b>Annex G (informative) Effect of sampling tube length.....</b>	<b>17</b>
<b>Bibliography.....</b>	<b>18</b>

## Foreword

ISO (the International Organization for Standardization) is a worldwide federation of national standards bodies (ISO member bodies). The work of preparing International Standards is normally carried out through ISO technical committees. Each member body interested in a subject for which a technical committee has been established has the right to be represented on that committee. International organizations, governmental and non-governmental, in liaison with ISO, also take part in the work. ISO collaborates closely with the International Electrotechnical Commission (IEC) on all matters of electrotechnical standardization.

The procedures used to develop this document and those intended for its further maintenance are described in the ISO/IEC Directives, Part 1. In particular, the different approval criteria needed for the different types of ISO documents should be noted. This document was drafted in accordance with the editorial rules of the ISO/IEC Directives, Part 2 (see [www.iso.org/directives](http://www.iso.org/directives)).

Attention is drawn to the possibility that some of the elements of this document may be the subject of patent rights. ISO shall not be held responsible for identifying any or all such patent rights. Details of any patent rights identified during the development of the document will be in the Introduction and/or on the ISO list of patent declarations received (see [www.iso.org/patents](http://www.iso.org/patents)).

Any trade name used in this document is information given for the convenience of users and does not constitute an endorsement.

For an explanation of the voluntary nature of standards, the meaning of ISO specific terms and expressions related to conformity assessment, as well as information about ISO's adherence to the World Trade Organization (WTO) principles in the Technical Barriers to Trade (TBT), see [www.iso.org/iso/foreword.html](http://www.iso.org/iso/foreword.html).

This document was prepared by Technical Committee ISO/TC 281, *Fine bubble technology*.

A list of all parts in the ISO 4240 series can be found on the ISO website.

Any feedback or questions on this document should be directed to the user's national standards body. A complete listing of these bodies can be found at [www.iso.org/members.html](http://www.iso.org/members.html).

## Introduction

The dissolved air flotation process is widely used for water treatment plant. This process used micro bubbles to remove particles by floating them on the surface. There are various factors to check the operation of the DAF plant. Many of these factors can be measured in field scale DAF plant. However, some factors are very difficult to measure in the field.

One of these factors is bubble volume concentration (BVC). BVC is usually used as index of the number of bubbles. Generally, BVC is evaluated by the water displacement method. This method measures the volume of bubbles as the volume of water displaced. The water displacement method is a direct way to give accurate BVC of bubble water. However, this method needs large equipment depending on the capacity of the bubble generator. So, it is almost impossible to measure BVC directly from the DAF plant. Lab and pilot test with the same nozzle of DAF plant and predictions based on the test results are most widely used.

Bubble bed depth is also difficult to measure in DAF plant. It is easy to observe the creation of a bubble bed interface in the middle part of the reactor by the naked eye in a lab and pilot scale DAF reactor manufactured with a transparent wall. Although it is not possible to present the interface by a single straight line, a bubble interface zone exists in which above the interface there are clouds of bubbles and below the interface almost no bubbles are observed. The centre of the bubble interface zone is defined as the bubble bed interface. Bubble bed depth is defined by the height from the water surface to the bubble bed interface as presented in Figure A.1. However, in a full-scale DAF plant, it is not easy to locate the bubble bed interface. The difficulty is that observation by the naked eye is not possible due to structural constraints.

Therefore, this document specifies indirect measurement methods of BVC and bubble bed depth. This approach can be useful for on-site inspection of DAF plant.

[ISO/TS 4240-1:2023](https://standards.iteh.ai/catalog/standards/sist/80ea0475-e0e1-4dee-a9c9-9680009ce941/iso-ts-4240-1-2023)

<https://standards.iteh.ai/catalog/standards/sist/80ea0475-e0e1-4dee-a9c9-9680009ce941/iso-ts-4240-1-2023>



# Fine bubble technology — Environmental applications —

## Part 1:

# Inspection method using online particle counter in dissolved air flotation (DAF) plant

## 1 Scope

This document specifies the bubble volume concentration and bubble bed depth measurement methods by online particle counter for checking DAF process performance in plant.

The test method of bubble volume concentration is made by measuring bubble size distribution in contact zone of DAF tank and calculating using formula. And bubble bed depth is evaluated by measuring the number of bubbles and particles according to the depth at five points in separation zone of DAF tank.

This document provides the advantages and limitations of using online particle counter in plant.

## 2 Normative references

The following documents are referred to in the text in such a way that some or all of their content constitutes requirements of this document. For dated references, only the edition cited applies. For undated references, the latest edition of the referenced document (including any amendments) applies.

ISO 20480-4, *Fine bubble technology — General principles for usage and measurement of fine bubbles — Part 4: Terminology related to microbubble beds*

## 3 Terms and definitions

For the purposes of this document, the terms and definitions given in ISO 20480-4 and the following apply.

ISO and IEC maintain terminology databases for use in standardization at the following addresses:

- ISO Online browsing platform: available at <https://www.iso.org/obp>
- IEC Electropedia: available at <https://www.electropedia.org>

### 3.1

#### **bubble volume concentration**

#### **BVC**

index of the volume of bubbles contained in the unit volume of water

Note 1 to entry: It is calculated by the ratio of the total bubble volume to the volume of generated bubble water during any given time, expressed in %.

[SOURCE: ISO 20480-4:2021, 3.16, modified — "index" has been removed from the term.]

### 3.2

#### **particle counting method**

indirect method to count the number of bubbles and its size distribution in a measurement

Note 1 to entry: Particle counting method (PCM) can trace the variation tendency of the BVC index.

Note 2 to entry: Effective range of particle counter to measure bubble size is from 1 µm to 100 µm.

Note 3 to entry: The sampling flowrate is normally adjusted, and the numbers of bubble are counted in the applied volume of sample.

### 3.3

#### **bubble and particle size distribution**

range (minimum to maximum) of bubble and particle size in a measurement

## 4 Principle

A particle counter is an instrument which is widely used for the determination of bubble size distribution (see [Annex A](#))<sup>[1]-[4]</sup>. Based on this characteristic, it can be used to evaluate BVC in DAF plant. Even though the result of this method is not accurate, it can be used to show the tendency of BVC according to time by real-time monitoring in DAF plant.

## 5 BVC measurement technique

### 5.1 Test equipment

This document aimed to evaluate BVC in DAF plant. Therefore, test equipment should be easy to move. [Figure 1](#) shows the example of equipment for BVC evaluation. The list of equipment is shown below.

- a) Online particle counter:
  - detecting range: approximately 10 µm to 100 µm;
  - support online-mode;
  - portable.
- b) Metering pump which can be operated at flowrate approximately 100 l/min to 200 l/min.
- c) Tube of sufficient length (the effect of sampling tube length is shown in [Annex G](#)).



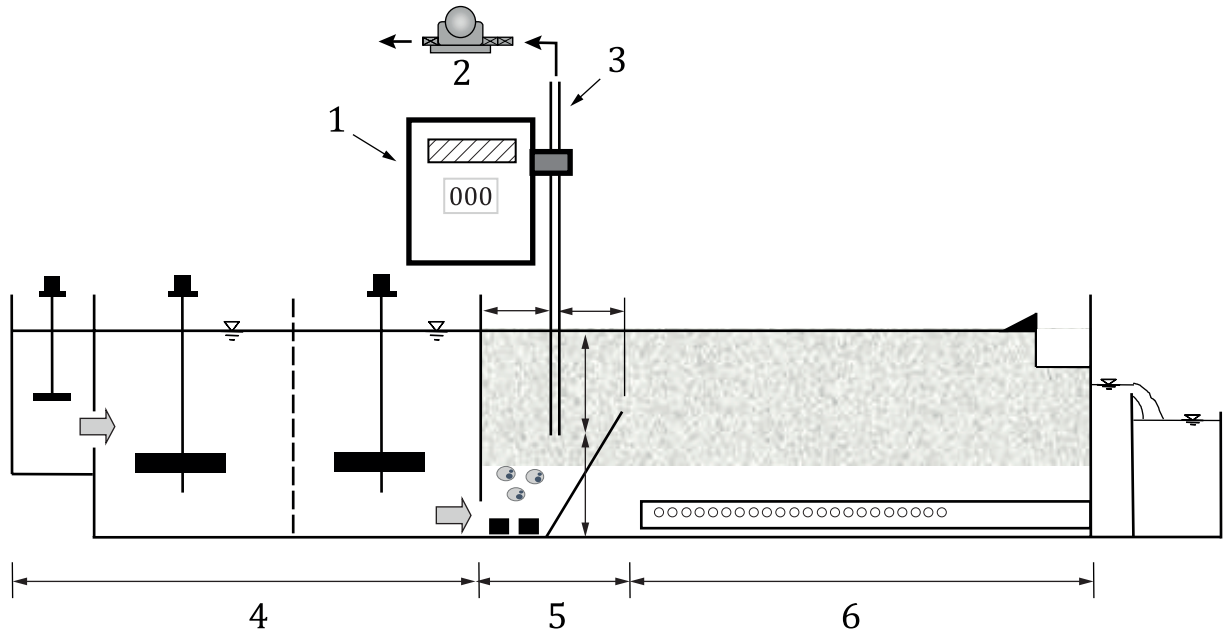

### Key

- 1 online particle counter
- 2 pump
- 3 tube
- 4 flocculation basin
- 5 contact zone
- 6 separation zone

**Figure 1 — Schematic diagram of equipment for BVC evaluation**

## 5.2 Procedure

- a) To minimize errors caused by particles entering the DAF tank, the inflow valve is locked in the DAF tank to prevent entry of untreated water. In this state, the bubble generator is operated to remove residual particles in the DAF tank and to make a stable state.
- b) The test equipment should be installed near the contact zone for evaluating BVC. The sample is taken in the middle of the point at the contact zone of the inlet and the outlet. Sampling depth is at half the depth of the contact zone. Tube for sampling is installed 1 m away from the sidewall to prevent from interruption of sidewall. Metering pump flowrate shall be approximately 100 l/min to 200 l/min to minimize the influence on the DAF bubble bed.
- c) The bubble size distribution is measured using online particle counter. The measurement time shall be  $5 \pm 1$  min to obtain stable data.
- d) Based on the measurement results, the bubble size distribution graph shall be drawn. The horizontal axis represents the bubble size range, and the vertical axis represents the number of bubbles. The example is shown in Figure A.1.
- e) Calculate BVC using [Formula \(1\)](#).

$$\text{BVC} = \frac{\sum n_i^* \times i^*}{Q} \times 100 \quad (1)$$

where

- BVC is the bubble volume concentration in %;
- $i^*$  is the volume of median size bubble of a certain range in ml;
- $n_i^*$  is the number of bubbles of a certain range whose median size bubble volume is  $i^*$  ;
- Q is the volume of sampled water from the contact zone in ml.

## 6 Bubble bed depth measurement technique

In the case of laboratory and pilot test, bubble bed depth can be measured with the naked eye by making DAF tank of transparent wall. However, it is impossible in DAF plant. This document provides the measurement method of bubble bed depth based on particle counting method. The accuracy of particle counting method was verified in [Annex C](#) through the experiments in pilot plant.

### 6.1 Test equipment

This document aimed to measure bubble bed depth in plant. Therefore, test equipment should be easy to move. [Figure 2](#) shows the typical example of equipment for bubble bed depth measurement. The list of equipment is shown below.

- a) Online particle counter:
- detecting range: approximately 10  $\mu\text{m}$  to 100  $\mu\text{m}$ ;
  - support online-mode;
  - portable.
- b) Metering pump which can be operated at flowrate 100 l/min stably.
- c) Tube of sufficient length from the bottom of DAF tank to online particle counter.
- d) Scaled pole with sufficient length for marking the position of the hose.

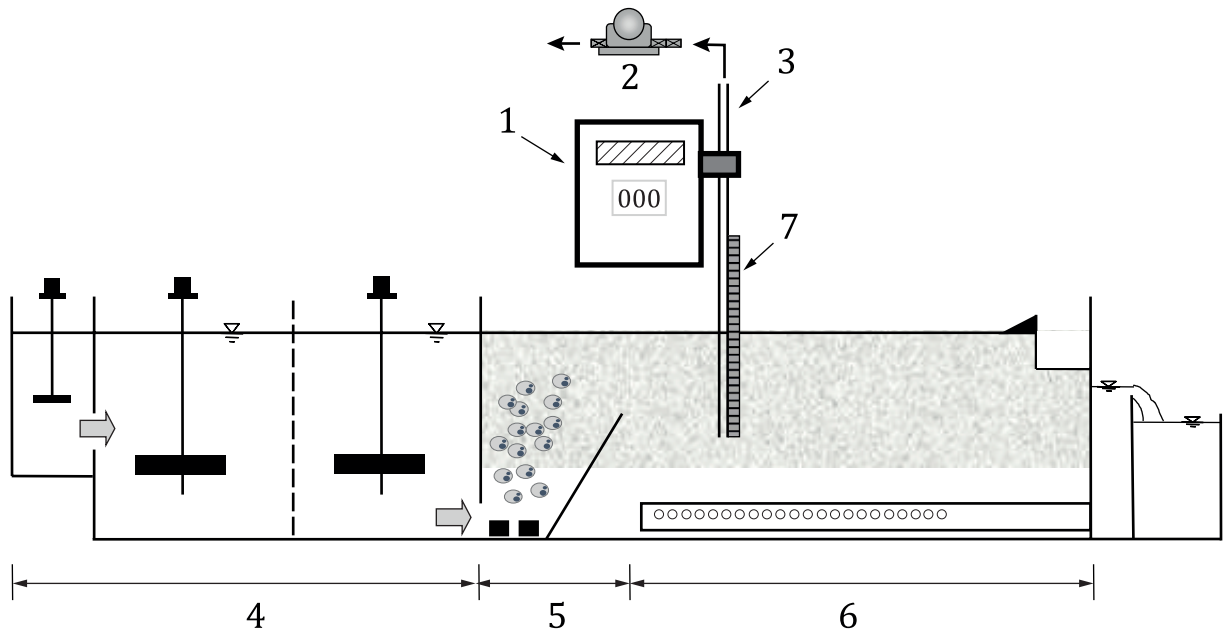

### Key

- 1 online particle counter
- 2 pump
- 3 tube
- 4 flocculation basin
- 5 contact zone
- 6 separation zone
- 7 scaled pole

Figure 2 — Schematic diagram of equipment for bubble bed depth measurement

## 6.2 Procedure

- a) In order to determine the horizontal profile, five points are selected as investigating point. They are inflow and outflow points of separate zone and three more points with equal interval between them.
- b) At each point, bubble and particle size distribution is investigated using online particle counter and metering pump according to depth while DAF process is operated. To make bubble bed depth constant, pressure of bubble generator and recycle ratio should remain constant during the measurement (see [Annex E](#)). Particles from inflow do not affect the measurement of the bubble layer (see [Annex F](#)). Detection range shall be set to approximately 10  $\mu\text{m}$  to 100  $\mu\text{m}$ . The samples are taken from 1 m away from the sidewall using a tube tied on a scaled pole at different depths. In this time, measuring depths shall have same interval. Metering pump flowrate shall be 100 l/min to minimize the influence on the DAF bubble bed.
- c) Based on the results of investigation at each point, bubble bed depth of the point is determined. After getting bubble and particle distribution according to depth, the number of bubbles and particles can be known. Based on the measurement results, the middle value of the interval in which the number is suddenly changed is determined as the bubble bed depth at that point. [Figure 3](#) shows one example of how to locate the bubble bed interface. For the operating conditions given above and listed in [Figure 3](#), the particle and bubble counts decreased rapidly in the depth range of 95 to 135 cm. From this result, the bubble bed depth is determined as  $105 \pm 0,5$  cm. Details of the experiment are shown in [Annex D](#).