



Designation: ~~E1974-06~~ Designation: E1974 - 11

Standard Specification for Shelter, Electrical Equipment S-250/G¹

This standard is issued under the fixed designation E1974; the number immediately following the designation indicates the year of original adoption or, in the case of revision, the year of last revision. A number in parentheses indicates the year of last reapproval. A superscript epsilon (ϵ) indicates an editorial change since the last revision or reapproval.

This standard has been approved for use by agencies of the Department of Defense.

1. Scope

1.1 This specification covers one type of lightweight field and mobile rigid wall shelter designed for transport by cargo truck, fixed or rotary winged aircraft, by rail, and ship, designated as Shelter, Electrical Equipment S-250/G.

1.2 The values stated in inch-pound units are to be regarded as the standard. The values given in parentheses are for information only.

1.3 The following safety hazards caveat refers only to the test methods portion of this specification. *This standard does not purport to address the safety concerns, if any, associated with its use. It is the responsibility of the user of the standard to establish appropriate safety and health practices and determine the applicability of regulatory limitations prior to use.*

2. Referenced Documents

2.1 ASTM Standards:²

C273 Test Method for Shear Properties of Sandwich Core Materials

D1621 Test Method for Compressive Properties of Rigid Cellular Plastics

D1622 Test Method for Apparent Density of Rigid Cellular Plastics

D2842 Test Method for Water Absorption of Rigid Cellular Plastics

E1370 Guide for Air Sampling Strategies for Worker and Workplace Protection

E1749 Terminology Relating to Rigid Wall Relocatable Shelters

E1773 Practice for Sealing Rigid Wall Tactical Shelters with Polysulfide Based Sealants

E1800 Specification for Adhesive for Bonding Foam Cored Sandwich Panels (160F Elevated Humidity Service), Type I Panels

E1801 Practice for Adhesive Bonding of Aluminum Facings in Foam and Beam Type Shelters

E1851 Test Method for Electromagnetic Shielding Effectiveness of Durable Rigid Wall Relocatable Structures

E1925 Specification for Engineering and Design Criteria for Rigid Wall Relocatable Structures

2.2 Commercial Standards:³

SAE AMS-W-6858 Welding, Resistance: Spot and Seam

2.3 Federal Air Regulation (FAR):⁴

FAR 25.853 Compartment Interior

2.4 Military Standards:⁵

MIL-F-14072 Finishes for Ground Based Electronic Equipment

MIL-DTL-55507 Shelter, Electrical Equipment (With or Without Equipment), Packaging of

MIL-STD-252 Wired Equipment, Classification of Visual and Mechanical Defects

MIL-STD-810 Environmental Engineering Considerations and Laboratory Tests

MIL-STD-2219 Fusion Welding for Aerospace Applications

MIL-STD-13231 Marking of Electronic Items

2.5 Drawings:⁶

DL-SM-B-563500 Shelter, Electrical Equipment, S-250/G

¹ This specification is under the jurisdiction of ASTM Committee E06 on Performance of Buildings and is the direct responsibility of Subcommittee E06.53 on Materials and Processes for Durable Rigid Wall Rigidwall Relocatable Structures.

Current edition approved Oct. Sept. 1, 2006; 2011. Published October 2006; 2011. Originally approved in 1998. Last previous edition approved in 2004; 2006 as E1974-01a; E1974-06. DOI: 10.1520/E1974-06; 10.1520/E1974-11.

² For referenced ASTM standards, visit the ASTM website, www.astm.org, or contact ASTM Customer Service at service@astm.org. For Annual Book of ASTM Standards volume information, refer to the standard's Document Summary page on the ASTM website.

³ Available from AMS Publications, Society of Automotive Engineers (SAE), 400 Commonwealth Dr., Warrendale, PA 15096-0001, http://www.sae.org.

⁴ Available from Flight Standards Service, Federal Aviation Administration (FAA), 800 Independence Ave., SW, Washington, DC 20591, http://www.faa.gov.

⁵ Available from Standardization Documents Order Desk, DODSSP, Bldg. 4, Section D, 700 Robbins Ave., Philadelphia, PA 19111-5098, http://www.dodssp.daps.mil.

⁶ Available from US Army Natick Soldier Center, ATTN: AMSRD-NSC-CP-CS, Kansas Street, Natick, MA 01760-5018.

DL-SM-B-649950 Modification Kit, EMI, MK-1092/G
DL-SM-B-650123 Shelter, Electrical Equipment, S-250/G (Shielded)
SM-D-208679 Outer Door Assembly
SM-D-208682 Inner Door Assembly
SM-C-435904 Keeper
SM-C-435937 Nameplate
SM-B-563559 Adhesive
SM-B-563655 Foam, Rigid, Plastic
SM-D-563754 Diagram, Flatness and Squareness
SM-C-564839 Gasket, Silicone
SC-C-595537 Padlock and Key
SC-B-595538 Bonding Procedure
SC-B-595539 Cleaning Procedure
SC-B-595564 Core Material Urethane, Light
SC-B-595565 Core Material Urethane, Heavy
SM-D-649951 Modification Kit EMI MK-1092/G
SM-D-649952 Sling Assembly
SM-D-649953 Shelter, Electrical Equipment S-250/G
SM-C-650082 Skid Assembly
SM-D-650085 Test Weight Installation
SM-C-650125 Nameplate
SC-D-781228 Door Fixture Construction Tightness Test
SC-D-781235 Drain, Fixture, Construction Tightness Test
SC-D-781236 Test Fixture Installation Construction Tightness Test
SC-B-964240 Nameplate, S-250 Shelter (With Rivnuts)

3. Terminology

3.1 Definitions:

3.1.1 *delaminations*—for purpose of this specification, a delamination is defined as the condition that exists within a shelter section or panel when two surfaces that once were bonded together are no longer bonded together. Delaminations may occur between any two bonded surfaces; examples include: separations between thermal barriers and members, between thermal barriers and skins, between members and core, or between skins and core. They may be the result of a poor quality bond or they could occur due to misuse or severe handling of the panels or the shelter after bonding. Test requirements of this specification shall not be construed as misuse or severe handling as these terms apply to the definition of delaminations.

3.1.2 *examination*—examination consists of simple, generally nondestructive determinations of compliance, without the use of special testing equipment.

3.1.3 *inspection*—inspection is the examination or testing, or both, of supplies to determine compliance with the applicable requirements. Sampling an element of inspection.

3.1.4 *testing*—testing consists of determinations of compliance using technical means.

3.1.5 *voids*—for the purpose of this specification, a void is defined as any unauthorized separation or space within a shelter panel or section, that is, any separation or space that is in conflict with the drawings or other contractual requirements. Voids range from gaps as wide as the space created by a missing piece of core material to as thin as a break in the continuity of material. Voids may be located solely within one type of material, such as a core material separation; they may exist between adjacent materials, such as unbonded core material; or they may be located between other parts within a panel, such as where a piece of material is missing, damaged, or undersized. Voids may have been created at the time of construction such as where a part was omitted; or may be created at a later time, such as a core separation or delaminated skin.

NOTE 1—All other terminology related to this specification is defined in Terminology E1749.

4. Materials Requirements

4.1 *General*—The materials and components shall be as specified herein and on the applicable drawings. Materials and components not definitely specified shall be of the quality normally used by the manufacturer provided the completed item complies with all the provisions of this specification.

4.2 *Adhesive*—The adhesive used to laminate in accordance 5.2 shall meet the requirements of Specification E1800 and the physical properties required by Drawing SM-B-563559 when tested in accordance with 10.1.

4.3 *Sealer*—The sealer, when tested in accordance with 10.1, used to meet the requirements of 5.3, shall have the following properties:

4.3.1 *Sealer Shear, Ambient*—The sealer and its bond to the aluminum shall have a minimum average shear strength of 200 psi (1.4 MPa) when tested at $80 \pm 10^\circ\text{F}$ ($27 \pm 6^\circ\text{C}$).

4.3.2 *Sealer Shear, Temperature Extreme*—The sealer and its bond to the aluminum shall have a minimum average shear strength of:

4.3.2.1 200 psi (1.4 MPa) when tested at $-65 \pm 5^\circ\text{F}$ ($-54 \pm 3^\circ\text{C}$), and

4.3.2.2 75 psi (520 KPa) when tested at $200 + 0 - 5^\circ\text{F}$ ($93 + 0 - 3^\circ\text{C}$)

4.3.3 *Sealer Shear, Humidity Exposure*—The sealer and its bond to the aluminum shall withstand exposure to 95 % relative humidity ± 5 % at $160 \pm 5^\circ\text{F}$ ($71 \pm 3^\circ\text{C}$) for fourteen days. After exposure the sealer shall have a minimum average shear strength of 75 psi (520 kPa) when tested at $160 \pm 5^\circ\text{F}$ ($71 \pm 3^\circ\text{C}$).

4.3.4 *Sealer Shear, Salt Spray Exposure*—The sealer and its bond to the aluminum shall withstand exposure to the salt spray test, Method 509.4 of MIL-STD-810F using a 20 % NaCl solution at $95 \pm 5^\circ\text{F}$ ($35 \pm 3^\circ\text{C}$) for fourteen days. After exposure the sealer shall have a minimum average shear strength of 200 psi (1.4 MPa) when tested at $80 \pm 10^\circ\text{F}$ ($27 \pm 6^\circ\text{C}$).

4.4 *Core Material*—The core material shall be a slab type foamed plastic. All three densities shall be used in the shelter. Disbursement within the shelter shall be in accordance with Specification E1370 and the drawings listed on DL-SM-B-563500. Density, compressive strength, flammability, water absorption, and shear strength properties shall be in accordance with Drawings SC-B-595564, SC-B-595565, and SM-B-563655, as applicable when tested in accordance with 10.2.

5. Construction Requirements

5.1 *General*—All parts, sub-assemblies, and the final assembly of Shelter, Electrical Equipment, S-250/G shall be constructed as specified herein and in accordance with the drawings listed on DL-SM-B-563500 or DL-SM-B-650123 when electromagnetic interference suppression is required (see 15.2). Shelters shall not be fork lifted at anytime during or after construction.

5.2 *Lamination*—During the laminating (bonding) process the mating of all panel constituents shall be bonded without delaminations, that is, discontinuation in, or separation between the constituents. Bonding shall be in accordance with Practice E1801 and SC-B-595538. Both sides of all panels prior to assembly into shelter form and all shelters shall be acoustically interrogated for delaminations using a tap hammer fabricated in accordance with Fig. 1. The shelter may be considered acceptable if it contains less than twelve distinctly individual delaminations or unbond type voids, provided none is greater than 2 in. (50 mm) across measured in any direction, and provided the shelter meets all other requirements.

5.3 *Seal*—All inner and outer skins, joints, edges, and hardware shall be sealed in a manner that will prevent collection and retention of water and provide a barrier against the entrance of water into any panel or the interior of the shelter. Unless otherwise specified on the shelter drawings, all exterior rivets, rivnuts, screws, and bolts shall be dipped in sealer prior to installation and the heads of rivets shall be covered with sealant after installation. (See Practice E1773).

5.4 *Cleaning*—All metal parts shall be cleaned at that stage of assembly indicated on the applicable drawing listed on DL-SM-B-563500 or DL-SM-B-650123, by a process in accordance with Practice E1773 and Drawing SC-B-595539 or as specified in the applicable portion of MIL-F-14072. All foam and wood parts shall be cleaned in accordance with the applicable portions of Practice E1801 and Drawing SC-B-595538, and Drawing SC-B-595538.

5.5 *Welding*—Arc and spot welding shall be applied as specified by the drawings. No grinding of welds shall be required except as specified by the drawings. The purchaser reserves the right to perform any of the inspections where such inspections are deemed necessary to ensure supplies and services conform to prescribed requirements.

5.5.1 *Arc Welding*—Inert gas shielded arc welding shall be in accordance with MIL-STD-2219.

5.5.2 *Spot Welding*—Spot welding shall be in accordance with SAE AMS-W-6858 Class B. Samples of the production items produced in accordance with the drawings shall be inspected by the supplier for appearance, external defects, sheet separation, surface identification, and weld location.

5.5.2.1 Test specimens shall be used to represent the manufacturing practice. Three single-spot shear specimens shall be used for checking purposes. Three single shear specimens shall be tested for ultimate strength and variation in shear strength.

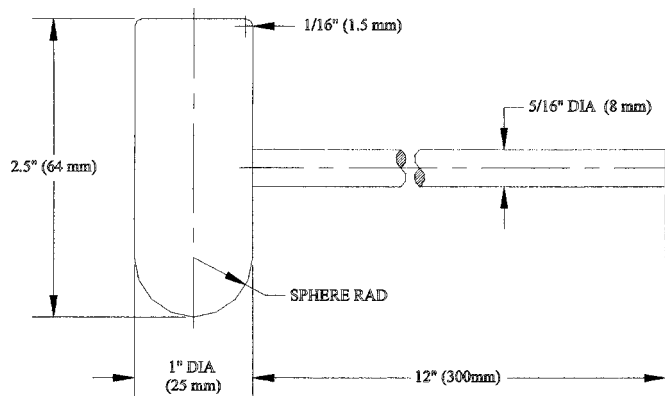

NOTE 1—Material—Aluminum 6061-T6 or equivalent.

NOTE 2—Tolerance— $\pm 1/32$ (1 mm).

FIG. 1 Tap Hammer

5.5.2.2 Failure of a test specimen or samples of a welded item shall be cause for rejection of the production quantity the specimen or sample represents.

5.6 *Riveting*—No more than one rivet/rivnut in ten and no more than two adjacent rivets/rivnuts shall exhibit any of the defects specified below, when inspected as specified in 10.6.

5.6.1 *Looseness*—There shall be no evidence of looseness parallel to the plane of the mating surface due to oversized holes or looseness perpendicular to the plane of the mating surfaces due to rivets/rivnuts not being tightly seated.

5.6.2 *Heads*—Rivet and rivnut heads shall not be cut, marred, chipped, eccentric, distorted, or otherwise mutilated. Countersunk rivets and rivnuts shall not project above or below the mating surface more than 15 % of the netting material thickness.

5.6.3 *Mating Surface and Materials*—The mating surface shall not be marred or indented due to rivet or rivnut installation, nor shall there be any distortion or warpage of the mating materials. There shall be no foreign material between riveted surfaces.

5.7 *Hardware*—All locks, latches, hinges, hinge pins, fasteners, bolts lifting and towing eyes, steps and other shelter hardware shall be made corrosion resistant in accordance with the applicable drawings listed on DL-SM-B-563500 or DL-SM-B-650123. The hardware shall be subjected to the test of 10.7 and shall show no evidence of corrosion or damage which in any way impairs the specified performance of the individual part.

5.7.1 *Padlocks and Keys*—All padlocks and keys shall be in accordance with SC-C-595537 and shall be interchangeable to the extent determined by 10.10.

5.8 *Finish Protective*—Protective finishes shall be in accordance with the applicable drawings listed on DL-SM-B-563500 or DL-SM-B-650123 and shall be free of the defects cited in the classification of visual finish defects of MIL-F-14072 when inspected as specified in 10.8 and 10.12.

5.9 *Marking*—Member centerline, punch marks, nameplates, instruction and data plates, and other markings shall be in accordance with MIL-STD-13231 and the applicable drawings listed on DL-SM-B-563500 or DL-SM-B-650123. Marking shall be inspected as specified in 10.9 and 10.12.

5.10 *Interchangeability*—Like units, subassemblies, assemblies and replaceable parts shall be physically and functionally interchangeable without modification of such items or of the shelter. Dimensions shall be within the limits specified on the applicable drawings listed on DL-SM-B-563500 or DL-SM-B-650123. Reliance shall not be placed on any unspecified dimension, rating, characteristic, etc. Individual items shall not be hand picked for fit or performance. To determine compliance with this requirement the items listed in 10.10 shall be measured and shall be in accordance with the dimensions and tolerances specified on the applicable drawings.

5.11 *Facsimiles*—When specified (see 15.2), the contractor shall provide facsimiles of the nameplate and all data and instruction plates required by DL-SM-B-563500 and DL-SM-B-650123. Each facsimile shall be in accordance with its drawing and shall include any and all information required to be inserted, except shelter serial number. Artwork shall be of a quality at least comparable to the drawings.

5.12 *Shelter Weight*—When inspected as specified in 10.12 and 10.13, the gross weight of the shelter, excluding the lift and tie-down device, (Drawing SM-D-649952) shall be as follows:

5.12.1 770 ± 20 lb (350 ± 9kg) without Mod Kit, EMI, MK-1092/G, and

5.12.2 782 ± 20 lb (355 ± 9 kg) with Mod Kit, EMI, MK-1092/G installed.

5.12.3 *Records*—Records shall be maintained of Serial numbers and actual weight of shelters and shall indicate if EMI Kit MK-1092/G is installed.

5.13 *Service Integrity*—Unless otherwise specified, tests specified herein shall not result in any discontinuity in the bond between the aluminum, foam, or wood thermal barriers, or all of these (that is, a delamination), or in any bulking, splitting, or any other deformation or structural weakening, or both of the shelter. The seal of 5.3 shall remain intact. All dimensions shall remain in accordance with the drawings listed on DL-SM-B-563500 or DL-SM-B-650123. Brackets, lugs, flanges, inserts, bolts, and any other mounting arrangement shall securely retain test loads, doors, and hardware. Any deformation of any mounting arrangement resulting from any specified test shall be within drawing tolerances and shall not cause degradation of its retaining ability or of specified shelter performance.

6. Environmental Requirements

6.1 *General*—The shelter shall be capable of meeting the following environmental test requirements with no harmful effect to any finish or performance capability (see 5.13).

6.2 *Moisture Resistance*—The shelter shall withstand daily exposure of up to 97 % relative humidity for 20 h and exposure at 100 % relative humidity (with condensation) for 4 h when tested as specified in 10.7.

6.3 *Temperature*—The shelter shall be capable of withstanding the following operating temperatures when tested as specified in 10.14:

6.3.1 *Operating Temperature*—Exposure to an ambient temperature in the range of –65 to 125°F (–54 to 52°C) plus a solar load such that the outside skin reaches a minimum temperature of 195°F (90°C); exposure at any one time not to exceed 75 h at the low temperature extreme and 4 h at the high temperature extreme.

6.3.2 *Non-Operating Temperature*—Exposure to an ambient temperature in the range of –80 to 160°F (–62 to 71°C); exposure at any one time not to exceed 24 h at the low temperature extreme and 4 h at the high temperature extreme.

6.4 *Heat Transfer*—The thermal characteristics of the shelter shall be such that the overall coefficient of heat transfer of the

shelter shall not exceed 0.50 BTUs per hour per square foot per degree Fahrenheit (2.9 Watts per square metre per degree Kelvin) when tested accordance with 10.15.

7. Structural Integrity Requirements

7.1 *General*—The shelter shall be capable of complying with the requirements of 7.2-7.6. When a payload is required, 1900 lb (860 kg) in accordance with Drawing SM-D-650085 shall be used. The requirements of 5.13 are applicable to all tests.

7.2 *Transportability*—The shelter, with payload, shall be capable of being picked up by a crane, transported while suspended from the crane, and lowered to any predetermined point on the ground. The shelter shall also be capable of being transported as follows:

7.2.1 *Rail Transport*—The shelter, with payload, shall be capable of being transported by railroad. Compliance with 10.16 shall constitute compliance with this requirement.

7.2.2 *Lift Transport Simulated*—The shelter, with payload, shall be capable of being suspended by its lifting eyes and exposed to 3.5 g's acceleration. Compliance with 10.17 shall constitute compliance with this requirement.

7.3 *Drop*—The shelter, with payload, shall be capable of being dropped as specified in 10.18. Every shelter subjected to drop tests shall be shipped only to a depot and shall have its nameplate “S-250 Shelter” (with rivnuts) in accordance with Drawing SC-B-964240 attached with rivets over the shelter nameplate, Drawing SM-C-435937 (SM-C-650125 if shielded) prior to shipment. Shipping document annotated (FOR DEPOT USE ONLY).

7.4 *Towing Simulated*—The shelter, with payload, shall withstand a force of a least 2000lb (900 kg) applied to each of the skid assemblies, and their attachment to the shelter, as specified in 10.19.

7.5 *Lifting and Towing Eye Assembly*—Each lifting and towing eye assembly, as attached to the shelter, shall withstand a minimum load of 5000 lb (2270 kg) applied in accordance with 10.20.

7.6 *Steps, Roof Access*—Each of the two recessed folding steps installed to provide access to the shelter roof shall withstand a load of 400 lb (180 kg) applied in accordance with 10.21.

8. Tightness Requirements

8.1 *General*—The shelter shall be capable of complying with the following:

8.2 *Torque, Door Latches*—Torques shall be measured as specified on Drawings SM-D-649951 and SM-D-649953 and shall be as specified in 10.22.

8.3 *Electromagnetic Interference (EMI) Shielding*—The shelter shall be capable of being shielded from electromagnetic interference (EMI) by the installation of Modification Kit, electromagnetic interference, MK-1092/G in accordance with DL-SM-B-649950 and with no other modification. Shielding shall provide a minimum attenuation of radiated and induced EMI fields as specified in Specification E1925 within the frequency range of 100 kHz to 10 GHz when tested in accordance with 10.23. Should a shelter subjected to the EMI test fail to pass, another shelter from the same lot shall be subjected to the EMI test.

8.4 *Construction Tightness*—The shelter shall be airtight to the extent that it shall be capable of achieving and maintaining a pressurized state without leakage when tested in accordance with 10.24.

8.5 *Watertightness*—The shelter shall be watertight when tested in accordance with 10.25. Shelter weight after testing shall be as specified in 5.12 after allowing 2 lb (1 kg) for the test weight mounting hardware of Drawing SM-D-650085, if applicable.

8.6 *Fording*—The shelter, without the use of special fording kits, shall be capable of being immersed in water to a depth of 30 in. (760 mm), as measured from the bottom of the shelter skids, with no failure of the seal specified in 5.3 or damage to the structure when tested and inspected as specified in 10.26. Shelter weight after testing shall be as specified in 5.12 after allowing 2 lb (1 kg) for the test weight mounting hardware of Drawing SM-D-650085 if applicable.

8.7 *Light Tightness*—No direct rays of light shall be visible through or around the air inlet louver assembly, as installed in the shelter and with the weather cover fully open, when tested in accordance with 10.27.

9. Other Requirements

9.1 *First Article*—When specified (see 15.2), a sample shall be subjected to first article inspection (see 15.3) in accordance with 11.1.

9.2 *Lift and Tie Down Device*—A combination lift and tie down device (sling) conforming to Drawing SM-D-649952 shall be provided as part of each shelter. Each leg of the device shall be capable of exceeding a tensile load of 9500 lb (4300 kg) as specified on the drawing and shall fail before slippage occurs at the sling sleeves when tested as specified in 10.28.

9.3 *Impact Panel*—The shelter panels shall withstand the test of 10.29. After the test, the panel shall be cross sectioned through the impact area and examined. Impact shall not result in rupture to either skin. No delaminations between skin and core or crushing of core is allowed outside a 3 in. (75 mm) radius from the center of impact.

9.4 *Fabrication and Assembly*—Samples (see 10.1.1) shall be assembled using parts, materials (and their amounts), and processes that will be employed in production, be fabricated and assembled in accordance with the specification, and meet all requirements specified herein.

9.5 *Workmanship*—The shelter shall be manufactured with the degree of workmanship normally considered appropriate for each of the areas listed under 5.0 (see 10.12).

10. Tests Required

10.1 *Coupon Samples*—Fabricate coupon samples for both adhesive and sealer tests in accordance with the physical properties paragraph of Drawing SM-B-563559-. Ten coupons are required for each of the five conditions for first article samples. Five coupons are required for each of the test conditions for production inspection.

10.1.1 *Comparability of Fabrication and Cure*—Fabricate samples and cure using materials, processes, and conditions compatible with those used on panels or shelters, or both, including:

10.1.1.1 Surface conditions of and method of preparing materials to be bonded,

10.1.1.2 Same batch and type of material,

10.1.1.3 Duration of, temperature, and pressure during cure,

10.1.1.4 Minimum cure time before handling, and

10.1.1.5 Time elapsed between application of adhesive to the first item (coupon or panel) in a lot to the application of pressure to the lot of items. Verify two or more part mixes of adhesive or sealer, or both, as being in accordance with the manufacturer’s recommendations before shear tests and range on coupons. Calibrate automatic dispensing machines, when used to mix or deliver, or both, two or more part adhesive or sealer, or both, at least once every 4 h. Cure sealer coupons at ambient temperature and the lap joint shall be under a pressure of approximately 5 psi (34 KPa).

10.1.2 *Shear Strength Tests*—Test coupons after being subjected to the specified exposure, if applicable, and at the specified temperature. Stabilize the temperature of the coupons at the specified level and measure by a thermocouple attached to the coupons over the lap joint. The thermocouple shall not be attached on that side of the lap joint closest to the heat or cold source nor shall the method of attachment impair the application or measurement of the shear force in any way. Apply the shear force to destruction with the rate of application constant at less than or equal to 1 in./min (25 mm/min). Any noncompliance with 4.2 for adhesive and 4.3 for sealer shall constitute failure of this test.

10.2 *Core Material Tests*—Subject core material samples to the following tests: for each test a set of five specimens is required for each type or grade of core material used in the shelter. Fabricate specimens from actual shelter core material pieces randomly selected from production core material parts. Specimen dimensions shall be within ± 0.015 in (± 0.40 mm). Except for flammability, compliance with 4.4 shall be determined by the average of the specimen results, with the lowest result no less than 90 % of the required value. Failure to meet the requirements of 4.4 shall constitute failure of this test.

10.2.1 *Apparent Density, Core Material*—Test five specimens, each 2 by 3 by 3 in. (50 by 75 by 75 mm) in accordance with Test Method D1622.

10.2.2 *Compressive Strength, Core Material*—Test five specimens each 2 by 3 by 3 in. (50 by 75 by 75 mm) in accordance with Procedure A of Test Method D1621, with the load applied to the 3 by 3 in. (75 by 75 mm) faces.

10.2.3 *Flammability*—Determine flame resistance of the five specimens, each ½ by 2 by 6 in. (13 by 50 by 150 mm), in accordance with Appendix F of FAR 25.853. The average extinguish time shall not exceed 15 s and average burn distance shall not exceed 6 in. (150 mm).

10.2.4 *Water Absorption*—Test three specimens, each 6 by 6 by 3 in. (150 by 150 by 75 mm) in accordance with Test Method D2842 with the following changes: weigh each specimen as it is first submerged; the weighing jig shall also be weighed at this time; for the final weight, the specimens must be weighed and removed from the water in reverse order, the water absorption shall be calculated as follows: (see Table 1):

$$\text{lb water/ft}^2 = (W_{2a} - W_{1a}) - (W_2 - W_3) / A \times 2.048 \text{ lb/ft}^2 / \text{g/cm}^2 \quad (1)$$

TABLE 1 First Article Specimens

Inspection	Quantity	Requirements Subsection	Test Subsection
Adhesive	50 coupons	4.2	10.1
Sealer	50 coupons	4.3	10.1
Core material:			
Density	5 for every grade or type	4.4	10.2.1
Compressive strength	5 for every grade or type	4.4	10.2.2
Flammability	5 for every grade or type	4.4	10.2.3
Water absorption	3 for every grade or type of urethane	4.4	10.2.4
Shear strength	5 for every grade or type	4.4	10.2.5
Lift and tie down device	1 complete	9.2	10.28
Impact panel	1 for every type core	9.3	10.29

where:

- W_{1a} = initial submerged weight of jig and samples (gm)
- W_{2a} = initial submerged weight of jig (gm),
- W_2 = final submerged weight of jig (gm),
- W_3 = final submerged weight of jig and samples (gm), and
- A = specimen surface area (cm²).

10.2.5 *Shear Strength*—Test five specimens, each ½ by 1½ by 6 in. (13 by 38 by 150 mm) in accordance with Test Method C273, except that the load shall be applied at a constant rate such that the maximum load will occur in one minute or more.

10.3 *Delamination Testing and Repair*—Individual panels and shelters shall be tested for delaminations by use of the tap hammer (see Fig. 1). Accomplish detection by tapping with the spherical end with a force equal to that produced when the head is raised approximately 1 in. (25 mm) above the panel and allowed to fall against the panel. A hammer blow on a laminated area produces a solid or firm or ringing sound whereas a delaminated area produces a deadened or hollow or metallic slap sound. Use the flat end of the hammer for tapping into corners. The extent of interrogation of each side of each panel shall be at least four hammer impacts per square foot of panel area between members and at least four hammer impacts per square foot over members on the interior side of the panel. Once a suspect area has been located, interrogate said area in detail by at least one hammer impact per inch in all directions. The delamination boundaries shall be marked as the point of acoustic change (deadening) plus ½ in. (13 mm). Failure to meet the requirements of 5.2 shall constitute failure of this test.

10.3.1 *Disposition of Delaminated Panels*—Reject all delaminated panels found before assembly into shelter form. Limit the number of rejected panels per calendar month to 5 % of all panels fabricated during that entire calendar month. Rejected panels in excess of this amount, even though repaired, shall not be accepted without the written approval from the purchaser.

10.3.2 *Disposition of Shelters Containing Delaminated Panels*—Reject all shelters found to contain delaminated panels. Limit the number of rejected shelters per calendar month to 1.0 % of the total contract quantity with the total no more than 5 % of the total contract quantity. A shelter shall not contain more than two repaired panels regardless of when it was repaired, that is, before or after use in the shelter. Shelters not complying with these limitations shall only be accepted by written approval of the purchaser. Maintain a record of the shelters containing a repaired panel, including which panel, location, and extent, and report as required elsewhere in the contract.

10.3.3 *Condition of Shelter Exterior Skins*—The exterior skin of the shelter panels may contain dents between structural members provided the skin is not punctured and provided the maximum depth of the dent does not exceed ¼ in. (1.5 mm) and no more than one shelter in ten contains one dent not exceeding ⅛ in. (3 mm) in depth.

10.3.4 *Delamination Repair:*

10.3.4.1 Document repair procedures for delaminations. The contractor may utilize a procedure only after receiving approval from the purchaser designated in the contract. The contractor should be aware and fully understand, however that should the purchaser later determine that the procedure is objectionable or inadequate, or its implementation does not fulfill its intended purpose, the purchaser may require that its use be discontinued and another consultation be held to resolve the inadequacy.

10.3.4.2 The maximum area of any single delamination and the maximum number of single delaminations per panel allowed is stated in 5.2. Multiple delaminations on a panel shall be separated by a structural member in order for that panel to be considered eligible for repair. A delamination on the interior side of a panel and another delamination on the exterior side of the same panel and with both delaminations being between the same two members shall not be considered separated.

10.4 *Cleaning Inspection*—Inspection of the cleaning process shall be in accordance with Practice E1773 and ~~SC-B-595539~~ SC-B-595539. Any noncompliance shall require re-cleaning of the parts processed since the last acceptable inspection.

10.5 *Welding Inspection*—Visually inspect arc welding in accordance with the requirements of maintenance sampling for production in accordance with MIL-STD-2219. For resistance welding, fabrication and inspection of production specimens and inspection of production parts shall be in accordance with SAE AMS-W-6858. Failure to meet the requirements of 5.5, with sub-paragraphs, shall constitute failure of this test.

10.6 *Riveting Inspection*—Examine riveted joints or rivnuts for tightness, the joined parts for damage, and for the rivet/rivnut heads to be properly seated and tight against their bearing surfaces. Replace rivets/rivnuts not meeting the requirements of 5.6 with properly installed rivets/rivnuts and then reinspect as specified above.

10.7 *Moisture Resistance Test*—Subject the shelter with doors open to the moisture resistance test of MIL-STD-810E, Method 507.3, Procedure II. After cycling has been completed, there shall be no evidence of delamination, cracking, corrosion, or deterioration to any part of the shelter and there shall be no malfunction of doors, latches, hinges, or any other hardware. Failure to meet the requirements of 5.7 and 6.2 shall constitute failure of this test.

10.8 *Finish Inspection*—Inspect finish in accordance with the quality assurance provisions of MIL-F-14072 including paint adhesion, and 10.12 of this specification. Failure to meet the requirements of 5.8 shall constitute failure of this test.

10.9 *Marking Inspection*—Visually inspect marking to determine compliance with 5.9. Failure to meet the requirements of 5.9 shall constitute failure of this test.

10.10 *Interchangeability Inspection*—Gauge or measure the dimensions listed below to determine compliance with the physical interchangeability requirements of 5.10. When a dimension is not within specified or design limits, it shall be considered a defect:

10.10.1 Dimension of doors and door openings,

- 10.10.2 Mounting dimensions of hinges and latches,
- 10.10.3 Size and mounting dimensions of skids,
- 10.10.4 Size and mounting dimensions of towing eyes,
- 10.10.5 Size and mounting dimensions of lifting eyes,
- 10.10.6 Dimensions of drain and drain plug, and
- 10.10.7 Check padlocks and keys for proper operation. Keys (four) shall be checked against at least three different padlocks.
- 10.11 *Dimensional Inspection*—Inspect the shelters and panels for conformance with the drawings in the following areas (see Footnotes A and B of Table 2):
 - 10.11.1 Items listed in Table 2,
 - 10.11.2 Interior and exterior dimensions,
 - 10.11.3 Location and visibility of punch marks for mounting members. Verify location at the individual panel stage of fabrication, and
 - 10.11.4 Verify locations of holes on painted interior shelter panel surfaces at the shelter assembled stage of fabrication.

10.12 *Visual and Mechanical Inspection*—Examine equipment for the requirements of construction (see Section 5). Comply with the item requirements listed in MIL-STD-252₂, Type 4, 5, 7, 8, 9 and 11 defects only. Further, classify a shelter weight above the required maximum (see 5.12) as a major defect.

10.13 *Shelter Weight Test*—Determine compliance with 5.12 by weighing on a platform beam or dial indicator scale. The platform of the scale shall be of sufficient extent so as to allow the placement of the entire shelter on it. The beam or indicator shall have 1 lb (± 0.5 kg) or less graduations. The scale shall have an accuracy of at least ± 1 lb (± 0.5 kg) or one-sixth of 1 % of full scale reading, whichever is smaller. Calibrate the scale at least twice per month using standard weights traceable to the National Institute for Standards and Technology. Failure to meet the requirements of 5.12 shall constitute failure of this test.

10.14 *Temperature Test*—Place the shelter, with both doors and the louver cover closed and with the drain hole closed in a manner acceptable to the purchaser in a temperature controlled room and subjected to the tests of 10.24.1 and 10.24.2. Measure air temperature by ten thermocouples located in accordance with Fig. 2. Outside thermocouples shall be provided with radiation shields of aluminum foil between the thermocouple and radiation surface. Air circulation shall not exceed a velocity of 7 miles per hour (11 kg/h) at 3 in. (75 mm) away from any shelter surface. Conduct inspection to determine compliance with 5.13 after completion of each test.

10.14.1 *Operating Temperature*—Stabilize the air temperature inside and outside the shelter at 120 to 125°F (49 to 52°C) for a period of 5 min, during which time check the doors and latches for ease of operation and freedom from binding. Then subject the exterior of the shelter roof panel to an additional simulated solar load applied as rapidly as possible to produce a temperature of 195°F (90°C) (minimum) on the outside skin of the roof panel as measured by 12 thermocouples located in accordance with Fig. 3. Obtain the simulated solar load using at least 28 lamps, type 1000T3, 230 volts.⁷ Arrange the lamps in four rows of seven lamps each and operate within 10 % of rated voltage. Maintain the 120 to 125° (49 to 52°C) ambient air temperature plus the roof solar load for a period of 4 h at which time remove the solar load and increase the air temperature both inside and outside the shelter

<https://standards.iteh.ai/catalog/standards/sist/e50c7838-728c-422f-9809-0e55c8f8ebca/astm-e1974-11>

⁷ Commercially available from several sources.

TABLE 2 Dimensional Inspection

Inspection	Drawing	Flatness Required
Frame flatness ^A		Within 0.03 in.
Door handle torque	SM-D-649953	<i>Torque required:</i> Small door 10 ft-lb (14 j) Large door 15 ft-lb (20 j)
Door handle torque (Shielded shelter)	SM-D-649951	Small door 20 ft-lb (27 j) Large door 25 ft-lb (34 j)
Shelter flatness ^{B, C}	SM-D-563754	<i>Deviation allowed:</i> 3 out of 36 ^D
Shelter squareness ^{B, C}	SM-D-563754	6 out of 36 ^{E, F}

^AFlatness of doors and openings at gasket and contact surfaces. This shall be inspected by checking the flatness of the four sides and the flatness at the corners using a straight edge. JO-Blocks, dial indicator height gage or surface plate, or both. Flatness shall be within 0.030 in. (1 mm) total.

^BMethod of measurement and tolerances with tools and gages used shall be subjected to approval by the purchaser technical activity designated in the contract.

^CThe purchaser technical activity designated in the contract shall be notified by the contractor 15 days before this inspection is to be performed.

^DFour deviations out of the 36 interior measurements on any one sample shall be cause for rejection of the shelter.

^ESeven deviations out of the 36 interior measurements on any one sample shall be cause for rejection of the shelter.

^FMore than two deviations in any one corner of the shelter be cause for rejection of the shelter.

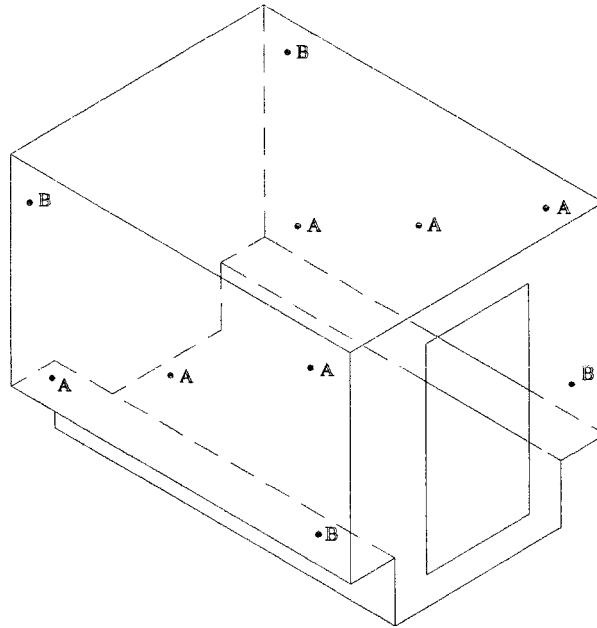

NOTE 1—A = Outside T.C.s approximately 10 in (250 mm) from corners.

NOTE 2—B = Inside T.C.s as shown

FIG. 2 Thermocouple Location on Sidewalls

TABLE 3 Sequence of First Article Inspection^A

Inspection	Requirements Subsection	Test Subsection
Cleaning	5.4	10.4
Welding	5.5	10.5
Lamination	5.2	10.3
Interchangeability	5.10	10.10
Riveting	5.6	10.6
Construction tightness	8.4	10.24
Finish	5.8	10.8
Marking	5.9	10.9
Dimensional (in accordance with stated drawing)	5.1	10.11
Visual and mechanical	5.1	10.12
Shelter weight	5.12	10.13
Door latch torque	8.2	10.22
Moisture resistance ^B	6.2	10.7
Temperature	6.3	10.14
Heat transfer	6.4	10.15
Rail transport	7.2.1	10.16
Drops ^C	7.3	10.18
Construction tightness ^{D,E}	8.4	10.24
Towing, simulated	7.4	10.19
Lifting and towing eye pulls	7.5	10.20
Lift transport, simulated	7.2.2	10.17
Steps, roof access	7.6	10.21
Light tightness	8.7	10.27
EMI shielding	8.3	10.23
Watertightness	8.5	10.25
Fording	8.6	10.26
Door latch torque (second time)	8.2	10.22

^AFirst article sample testing and shelter testing shall not begin until at least seven days after the sealer application, including application of touch-up sealer.

^BFirst article specimen testing shall be completed no later than the end of this test (see 11.1.1). This inspection shall not begin until at least seven days after final finish application including touch-up paint.

^CSee Note 10 of Table 7.

^DFor correlation data purposes only. CTT (construction tightness test) results are not to be used as accept/reject criteria for the drop test.

^EDoor portion and gasket portion only.

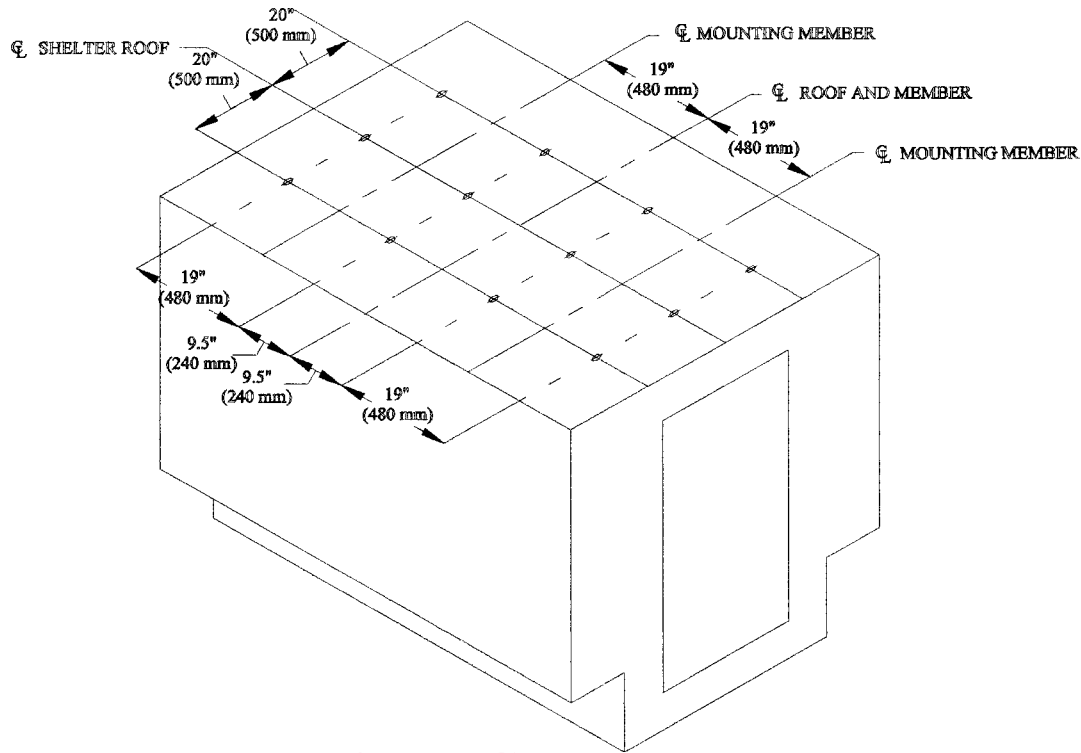

NOTE 1—Tolerance $\pm 1/2$ (13 mm).

FIG. 3 Thermocouple Location of Roof

to 160 – 0 + 5°F (71 – 0 + 3°C) (as measured by the ten thermocouples of Fig. 2) as rapidly as possible and maintain for 5 min. Then completely remove the shelter from the heated chamber to an ambient temperature between 60 and 85°F (16 and 29°C).

NOTE 2—The length and position of the thermocouple's wires shall permit complete removal. Open the shelter drain hole prior to shelter removal.

10.14.2 *Storage Test*—Subject the shelter alternately to Method 501.4 and Method 502.4 of MIL-STD-810EF, except perform three cycles of each test (high temperature and low temperature). The cycles shall range from 160°F (71°C) for the high temperature tests and –80°F (–62°C) for low temperature tests (as measured by the ten thermocouples of Fig. 2). In addition, all doors and latches shall operate freely without binding at either temperature extreme.

10.15 *Heat Transfer Test*—Place the shelter in a temperature controlled room that is at a constant temperature of –40 + 5°F (–40 + 3°C) outside the shelter. The walls and ceiling of the chamber shall be a minimum distance of 2½ ft (750 mm) from the walls and ceiling of the shelter. Place a 3KW electric coil open frame heater at the center of the shelter floor. Place a multi-speed 10 or 12 in. (250 or 300 mm) diameter fan 6 in. (150 mm) in the back of the heater such as to direct air through the heater toward the front of the shelter at an inclined angle of 15 degrees. Maintain a stabilized temperature inside the shelter of not less than 100°F (38°C) above the outside. Air circulation shall not exceed a velocity of seven miles per hour (11 kg/h) at 3 in. (75 mm) away from any shelter surface. Stabilize electrical power input and temperatures when the inside and outside groups of thermocouples each vary less than 2½ °F (1.5°C) while maintaining the minimum differential of 100°F (38°C) located in accordance with Fig. 2. Temperature and electrical power input stabilization for at least 30 min. In the stabilized condition the electrical power input will equal the heat loss. Do not change the rpm of the fan. The power input to the fan and heater shall be constant during the stabilization period and measured by an ammeter, voltmeter, and wattmeter in the electrical circuit. Use the power input, the average inside and outside temperature, and the inside surface area of the shelter in calculating the overall coefficient of heat transfer, that shall be no greater than that specified in 6.4. Failure to meet the requirements of 6.4 shall constitute failure of this test.

NOTE 3—To avoid a large pressure differential between the inside and outside of the shelter, a form of pressure relief should be incorporated into the drain hole.

10.16 *Rail Transport, Impact Test*—Load the shelter with a 1900 lb (860 kg) load in accordance with Drawing SM-D-650085 and load on a railroad flat car. Perform the test in accordance with MIL-STD-810F Procedure VII. Impact test the shelter and position in both the longitudinal and lateral directions on the flat car. Rail transportability tests shall be performed for impacts at 4, 6, and 8 mph (6, 10, and 13 km/h) and 8 mph (13 km/h) reversed. Make a damage survey after each impact. The shelter shall have sustained no deformation and shall meet the requirements of 7.2.1 and 5.13. Failure to meet the requirements of 7.2.1 and 5.13 shall constitute a failure of this test.