**Plastics — Determination of the
viscosity of polymers in dilute solution
using capillary viscometers —**

**Part 1:
General principles**

*Plastiques — Détermination de la viscosité des polymères en solution
diluée à l'aide de viscosimètres à capillaires —*

Partie 1: Principes généraux

IT
(<https://standards.iteh.ai>)
Document Preview

[ISO 1628-1:2021](https://standards.iteh.ai/catalog/standards/iso/30894539-bb15-48bc-909d-89fcd46b1a3b/iso-1628-1-2021)

<https://standards.iteh.ai/catalog/standards/iso/30894539-bb15-48bc-909d-89fcd46b1a3b/iso-1628-1-2021>



iTeh Standards
(<https://standards.iteh.ai>)
Document Preview

[ISO 1628-1:2021](https://standards.iteh.ai/catalog/standards/iso/30894539-bb15-48bc-909d-89fcd46b1a3b/iso-1628-1-2021)

<https://standards.iteh.ai/catalog/standards/iso/30894539-bb15-48bc-909d-89fcd46b1a3b/iso-1628-1-2021>



COPYRIGHT PROTECTED DOCUMENT

© ISO 2021

All rights reserved. Unless otherwise specified, or required in the context of its implementation, no part of this publication may be reproduced or utilized otherwise in any form or by any means, electronic or mechanical, including photocopying, or posting on the internet or an intranet, without prior written permission. Permission can be requested from either ISO at the address below or ISO's member body in the country of the requester.

ISO copyright office
CP 401 • Ch. de Blandonnet 8
CH-1214 Vernier, Geneva
Phone: +41 22 749 01 11
Email: copyright@iso.org
Website: www.iso.org

Published in Switzerland

Contents

	Page
Foreword	iv
1 Scope	1
2 Normative references	1
3 Terms and definitions	1
3.1 Terms related to any liquid	1
3.2 Terms related to polymer solutions	2
4 Principle	4
5 Apparatus	5
6 Solutions	8
6.1 Preparation	8
6.2 Concentration	9
7 Temperature of measurement	9
8 Procedure	9
8.1 General	9
8.2 Preparing and charging the viscometer	9
8.3 Efflux time measurement	10
9 Expression of results	10
9.1 Reduced viscosity and intrinsic viscosity	10
9.2 <i>K</i> -value	11
10 Test report	11
Annex A (normative) Cleaning of apparatus	12
Annex B (informative) Notes on sources of error	13
Bibliography	16

<https://standards.iteh.ai/>

<https://standards.iteh.ai/catalog/standards/iso/30894539-bb15-48bc-909d-89fcd46b1a3b/iso-1628-1-2021>

Foreword

ISO (the International Organization for Standardization) is a worldwide federation of national standards bodies (ISO member bodies). The work of preparing International Standards is normally carried out through ISO technical committees. Each member body interested in a subject for which a technical committee has been established has the right to be represented on that committee. International organizations, governmental and non-governmental, in liaison with ISO, also take part in the work. ISO collaborates closely with the International Electrotechnical Commission (IEC) on all matters of electrotechnical standardization.

The procedures used to develop this document and those intended for its further maintenance are described in the ISO/IEC Directives, Part 1. In particular, the different approval criteria needed for the different types of ISO documents should be noted. This document was drafted in accordance with the editorial rules of the ISO/IEC Directives, Part 2 (see www.iso.org/directives).

Attention is drawn to the possibility that some of the elements of this document may be the subject of patent rights. ISO shall not be held responsible for identifying any or all such patent rights. Details of any patent rights identified during the development of the document will be in the Introduction and/or on the ISO list of patent declarations received (see www.iso.org/patents).

Any trade name used in this document is information given for the convenience of users and does not constitute an endorsement.

For an explanation of the voluntary nature of standards, the meaning of ISO specific terms and expressions related to conformity assessment, as well as information about ISO's adherence to the World Trade Organization (WTO) principles in the Technical Barriers to Trade (TBT), see www.iso.org/iso/foreword.html.

This document was prepared by Technical Committee ISO/TC 61, *Plastics*, Subcommittee SC 5, *Physical-chemical properties*, in collaboration with the European Committee for Standardization (CEN) Technical Committee CEN/TC 249, *Plastics*, in accordance with the Agreement on technical cooperation between ISO and CEN (Vienna Agreement).

This fourth edition cancels and replaces the third edition (ISO 1628-1:2009), which has been technically revised. It also incorporates the Amendment 1 ISO 1628-1:2009/Amd 1:2012.

The main changes compared to the previous edition are as follows:

- ISO 3205 (withdrawn) has been deleted from [Clause 2](#);
- the figure keys have been revised;
- nominal viscometer constant has been added to [Table 1](#);

A list of all parts in the ISO 1628 series can be found on the ISO website.

Any feedback or questions on this document should be directed to the user's national standards body. A complete listing of these bodies can be found at www.iso.org/members.html.

Plastics — Determination of the viscosity of polymers in dilute solution using capillary viscometers —

Part 1: General principles

1 Scope

This document defines the general conditions for the determination of the reduced viscosity, intrinsic viscosity and K -value of organic polymers in dilute solution. It defines the standard parameters that are applied to viscosity measurement.

This document is used to develop standards for measuring the viscosities in solution of individual types of polymer. It is also used to measure and report the viscosities of polymers in solution for which no separate standards exist.

2 Normative references

The following documents are referred to in the text in such a way that some or all of their content constitutes requirements of this document. For dated references, only the edition cited applies. For undated references, the latest edition of the referenced document (including any amendments) applies.

ISO 3105, *Glass capillary kinematic viscometers — Specifications and operating instructions*

ISO 80000-1, *Quantities and units — Part 1: General*

ISO 80000-4, *Quantities and units — Part 4: Mechanics*

<https://standards.iteh.ai/catalog/standards/iso/30894539-bb15-48bc-909d-89fcd46b1a3b/iso-1628-1-2021>

3 Terms and definitions

For the purposes of this document, the terms and definitions given in ISO 80000-1, ISO 80000-4 and the following apply.

ISO and IEC maintain terminological databases for use in standardization at the following addresses:

- ISO Online browsing platform: available at <https://www.iso.org/obp>
- IEC Electropedia: available at <http://www.electropedia.org/>

3.1 Terms related to any liquid

3.1.1

viscosity

property of a fluid sheared between two parallel plates, one of which moves relative to the other in uniform rectilinear motion in its own plane, defined by the Newton formula

$$\tau = \eta \dot{\gamma}$$

where

τ is the shear stress;

η is the viscosity;

$\dot{\gamma}$ is the velocity gradient or rate of shear, given by $\frac{dV}{dz}$ where V is the velocity of one plane relative to the other and z the coordinate perpendicular to the two planes.

Note 1 to entry: The dimensions of viscosity are $ML^{-1}T^{-1}$.

Note 2 to entry: The units of viscosity are Pa·s.

Note 3 to entry: For practical use, the sub-multiple 10^{-3} Pa·s is more convenient.

Note 4 to entry: Viscosity is usually taken to mean “Newtonian viscosity”, in which case the ratio of shearing stress to velocity gradient is constant. In non-Newtonian behaviour, which is the usual case with high-polymer solutions, the ratio varies with the shear rate. Such ratios are often called “apparent viscosities” at the corresponding shear rate.

3.1.2 viscosity/density ratio kinematic viscosity

ν
ratio defined by the formula

$$\nu = \frac{\eta}{\rho}$$

where ρ is the density of the fluid at the temperature at which the viscosity is measured

Note 1 to entry: The dimensions of kinematic viscosity are L^2T^{-1} .

Note 2 to entry: The units of kinematic viscosity are $m^2 \cdot s^{-1}$.

Note 3 to entry: For practical use, the sub-multiple $10^{-6} m^2 \cdot s^{-1}$, i.e. $mm^2 \cdot s^{-1}$, is more convenient.

3.2 Terms related to polymer solutions

3.2.1 relative viscosity viscosity ratio

η_r
ratio of the viscosity of the polymer solution (of stated concentration) η and the viscosity of the pure solvent η_0 , at the same temperature:

$$\eta_r = \frac{\eta}{\eta_0}$$

Note 1 to entry: The ratio has no dimensions.

3.2.2 relative viscosity increment viscosity ratio increment and specific viscosity viscosity ratio minus one

$$\left(\frac{\eta}{\eta_0} \right) - 1 = \frac{\eta - \eta_0}{\eta_0}$$

Note 1 to entry: The increment has no dimensions.

3.2.3 reduced viscosity viscosity number

I

ratio of the relative viscosity increment to the polymer concentration c in the solution:

$$I = \frac{\eta - \eta_0}{\eta_0 c}$$

Note 1 to entry: The dimensions of reduced viscosity are L^3M^{-1} .

Note 2 to entry: The units of reduced viscosity are m^3/kg .

Note 3 to entry: For practical use, the sub-multiple $10^{-3} m^3/kg$, i.e. cm^3/g , is more convenient and the commonly quoted numerical values for reduced viscosity (viscosity number) use these practical units.

Note 4 to entry: The reduced viscosity is usually determined at low concentration (less than $5 kg/m^3$, i.e. $0,005 g/cm^3$), except in the case of polymers of low molar mass, for which higher concentrations is necessary.

3.2.4 inherent viscosity logarithmic viscosity number

ratio of the natural logarithm of the viscosity ratio to the polymer concentration in the solution:

$$\frac{\ln\left(\frac{\eta}{\eta_0}\right)}{c}$$

Note 1 to entry: The dimensions and units are the same as those given in [3.2.3](#).

Note 2 to entry: The inherent viscosity is usually determined at low concentration (less than $5 kg/m^3$, i.e. $0,005 g/cm^3$), except in the case of polymers of low molar mass, for which higher concentrations is necessary.

3.2.5 intrinsic viscosity limiting viscosity number

$[\eta]$

limiting value of the reduced viscosity or of the *inherent viscosity* ([3.2.4](#)) at infinite dilution:

$$[\eta] = \lim_{c \rightarrow 0} \left(\frac{\eta - \eta_0}{\eta_0 c} \right)$$

$$[\eta] = \lim_{c \rightarrow 0} \frac{\ln\left(\frac{\eta}{\eta_0}\right)}{c}$$

Note 1 to entry: The dimensions and units are the same as those given in [3.2.3](#).

Note 2 to entry: The effect of the shear rate on the functions defined in [3.2.1](#) to [3.2.5](#) has been neglected, since this effect is usually negligible for values of the reduced viscosity, inherent viscosity and intrinsic viscosity less than $0,5 m^3/kg$, i.e. $500 cm^3/g$. Strictly speaking, all these functions can be defined at the limiting (preferably infinitely small) value of the shear rate.

3.2.6 *K*-value

constant, independent of the concentration of the polymer solution and peculiar to the polymer sample, which is a measure of the average degree of polymerization:

$$K\text{-value} = 1\ 000\ k$$

Note 1 to entry: According to H. Fikentscher^[1], k is calculated as follows:

$$\lg \eta_r = \left(\frac{75k^2}{1+150kc} + k \right) 100c$$

and therefore

$$k = \frac{1,5 \lg \eta_r - 1 + \sqrt{1 + \left(\frac{2}{c} + 2 + 1,5 \lg \eta_r \right)^2}}{150 + 300c}$$

where

$\eta_r = \frac{\eta}{\eta_0}$ is the viscosity ratio (see 3.2.1);

c is the concentration, in 10^3 kg/m^3 , i.e. g/cm^3 .

Note 2 to entry: A limiting viscosity number $[\eta]_k$ can be calculated from k :

$$[\eta]_k = 230,3(75k^2 + k)$$

4 Principle

The data needed for the evaluation of the functions defined in 3.2 are obtained by means of a capillary-tube viscometer. The efflux times of a given volume of solvent t_0 and of solution t are measured at fixed temperature and atmospheric-pressure conditions in the same viscometer. The efflux time of a liquid is related to its viscosity by the Poiseuille-Hagenbach-Couette formula as shown in Formula (1):

$$v = \frac{\eta}{\rho} = Ct - \left(\frac{A}{t^2} \right) \tag{1}$$

where

[ISO 1628-1:2021](https://standards.iteh.ai/catalog/standards/iso/30894539-bb15-48bc-909d-89fcd46b1a3b/iso-1628-1-2021)

<https://standards.iteh.ai/catalog/standards/iso/30894539-bb15-48bc-909d-89fcd46b1a3b/iso-1628-1-2021>

v is the viscosity/density ratio ;

C is a constant of the viscometer;

A is a parameter of the kinetic-energy correction;

ρ is the density of the liquid;

t is the efflux time.

For the purposes of this document, the kinetic energy correction $\left(\frac{A}{t^2} \right)$ shall be regarded as negligible when it is less than 3 % of the viscosity of the solvent. Hence, Formula (1) can be reduced to Formula (2):

$$v = \frac{\eta}{\rho} = Ct \tag{2}$$

Moreover, if the solution concentrations are limited so that the solvent density ρ_0 and that of the solution ρ differ by less than 0,5 %, the viscosity ratio $\frac{\eta}{\eta_0}$ will be given by the so-called “efflux time ratio” $\frac{t}{t_0}$.

The need for these constraints, and the consequences of not observing them, is described in Annex B.

5 Apparatus

5.1 Capillary viscometer, of the suspended-level Ubbelohde type.

The use of a viscometer having the dimensions given in [Figure 1](#) or [Figure 2](#) is strongly recommended. Furthermore, it is strongly recommended that the size of the viscometer be chosen from among those listed in [Table 1](#). The choice is determined by the viscosity/density ratio of the solvent at the temperature of the measurement, as indicated in [Table 1](#). The next-smaller viscometer may also be used.

Other types of viscometer listed in ISO 3105 may be used, provided they give results equivalent to those given by the particular size of Ubbelohde viscometer chosen on the basis of the criteria specified in the preceding paragraph. In cases of dispute, an Ubbelohde viscometer shall be used.

With automated apparatus, fitted with special timing devices, equivalent results with larger sizes of capillary than those listed for the appropriate solvent viscosity/density ratio in [Table 1](#) can be obtained.

5.2 Viscometer holder, suitable to hold the viscometer firmly in the thermostatic bath ([5.3](#)) in the vertical position.

iTeh Standards
(<https://standards.iteh.ai>)
Document Preview

[ISO 1628-1:2021](#)

<https://standards.iteh.ai/catalog/standards/iso/30894539-bb15-48bc-909d-89fcd46b1a3b/iso-1628-1-2021>

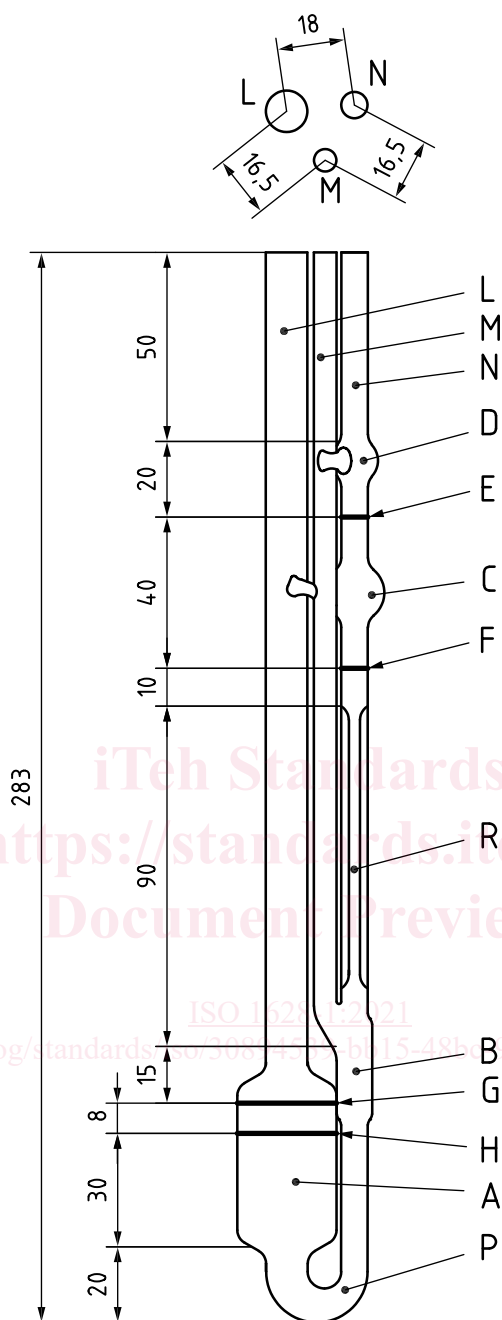

Key

- | | | | |
|---------|---|---|--|
| A | lower reservoir 26 mm internal diameter | L | mounting tube 11 mm internal diameter |
| B | suspended level bulb | M | lower vent tube 6 mm internal diameter |
| C | timing bulb | N | upper vent tube 7 mm internal diameter |
| D | upper reservoir | P | connecting tube |
| E and F | timing marks | R | working capillary |
| G and H | filling marks | | |

Figure 1 — Ubbelohde viscometer