Wheelchair seating —
Part 13:
Determination of the lateral stability
property of a seat cushion

iTeh STANDARD PREVIEW
(standards.iteh.ai)

[ISO 16840-13:2021](https://standards.iteh.ai/catalog/standards/sist/5601d4f0-f53c-4359-a415-59f5a283ecda/iso-16840-13-2021)

<https://standards.iteh.ai/catalog/standards/sist/5601d4f0-f53c-4359-a415-59f5a283ecda/iso-16840-13-2021>



iTeh STANDARD PREVIEW
(standards.iteh.ai)

ISO 16840-13:2021
<https://standards.iteh.ai/catalog/standards/sist/5601d4f0-f53c-4359-a415-59f5a283ecda/iso-16840-13-2021>



COPYRIGHT PROTECTED DOCUMENT

© ISO 2021

All rights reserved. Unless otherwise specified, or required in the context of its implementation, no part of this publication may be reproduced or utilized otherwise in any form or by any means, electronic or mechanical, including photocopying, or posting on the internet or an intranet, without prior written permission. Permission can be requested from either ISO at the address below or ISO's member body in the country of the requester.

ISO copyright office
CP 401 • Ch. de Blandonnet 8
CH-1214 Vernier, Geneva
Phone: +41 22 749 01 11
Email: copyright@iso.org
Website: www.iso.org

Published in Switzerland

Contents

	Page
Foreword.....	iv
Introduction.....	v
1 Scope.....	1
2 Normative references.....	1
3 Terms and definitions.....	1
4 Abbreviations.....	2
5 Apparatus.....	2
5.1 RCLI.....	2
5.2 RCLI cover.....	2
5.3 Stability test rig.....	2
5.4 Tilt angle measurement device.....	3
6 Test environment.....	3
7 Preparation and setup of cushion.....	4
7.1 Choice of cushion.....	4
7.2 Preconditioning the cushion.....	4
8 Cushion lateral stability test method.....	4
8.1 General.....	4
8.2 Test procedure.....	4
8.3 Method of calculation.....	5
8.4 Test report.....	6
Annex A (informative) Method for using pressure mapping to characterize behaviour of reaction forces during the stability property test.....	7
Bibliography.....	9

Foreword

ISO (the International Organization for Standardization) is a worldwide federation of national standards bodies (ISO member bodies). The work of preparing International Standards is normally carried out through ISO technical committees. Each member body interested in a subject for which a technical committee has been established has the right to be represented on that committee. International organizations, governmental and non-governmental, in liaison with ISO, also take part in the work. ISO collaborates closely with the International Electrotechnical Commission (IEC) on all matters of electrotechnical standardization.

The procedures used to develop this document and those intended for its further maintenance are described in the ISO/IEC Directives, Part 1. In particular, the different approval criteria needed for the different types of ISO documents should be noted. This document was drafted in accordance with the editorial rules of the ISO/IEC Directives, Part 2 (see www.iso.org/directives).

Attention is drawn to the possibility that some of the elements of this document may be the subject of patent rights. ISO shall not be held responsible for identifying any or all such patent rights. Details of any patent rights identified during the development of the document will be in the Introduction and/or on the ISO list of patent declarations received (see www.iso.org/patents).

Any trade name used in this document is information given for the convenience of users and does not constitute an endorsement.

For an explanation of the voluntary nature of standards, the meaning of ISO specific terms and expressions related to conformity assessment, as well as information about ISO's adherence to the World Trade Organization (WTO) principles in the Technical Barriers to Trade (TBT), see www.iso.org/iso/foreword.html.

This document was prepared by Technical Committee ISO/TC 173, *Assistive products*, Subcommittee SC 1, *Wheelchairs*.

<https://standards.iteh.ai/catalog/standards/sist/5601d4f0-f53c-4359-a415-59f528794d50/iso-16840-13-2021>

A list of all parts in the ISO 16840 series can be found on the ISO website.

Any feedback or questions on this document should be directed to the user's national standards body. A complete listing of these bodies can be found at www.iso.org/members.html.

Introduction

The seat cushion, as the base of support for the wheelchair occupant, affects postural stability by resisting moments when the occupant's centre of mass is displaced. Research exploring the influence of cushion design and setup on pelvic orientation and measures of postural stability is limited. Standard test methods, highlighted in ISO 16840-2, should be used to characterize tissue integrity management properties of wheelchair seat cushions such as immersion, envelopment, hysteresis, impact damping, recovery, and horizontal stiffness.

This document provides details of test equipment and a method for the measurement of the cushion's ability to resist movements contributing to pelvic obliquity. Changes in pelvic obliquity, as a result of a shift in the centre of mass, can affect stability and mobility depending on the response of the cushion, the occupant's core muscle strength, etc. Moments in the test method are created by shifting a vertical load laterally on the top surface of a standard rigid cushion loading indenter (RCLI) simulating the buttocks and upper thighs. The test method described in this document is intended to differentiate lateral stability performance between cushions and is not appropriate for ranking cushions nor for directly matching this characteristic with an individual occupant's requirements. The link to clinical efficacy, although implied, has not been validated. It is intended that this document will evolve when the evidence of clinical relevance is confirmed. Test conditions (e.g. the RCLI) simulate a symmetric anatomy. The loads used in this document are based on the 40th to 60th percentile wheelchair occupant and are not intended to characterize any cushion properties under bariatric loading conditions or to assess the weight capacity of a cushion.

There are other stability issues of relevance to the occupant, but which are not addressed in this document. For example, because the positions of the occupant's thighs, lower legs, and feet can counterbalance any instability elements of the cushion, an anterior-posterior stability test carries lesser significance to the occupant and is not included. This document also does not address aspects of wheelchair sitting stability related to the resistance or assistance that the cushion provides to the occupant regaining a neutral pelvis following a lateral tilt as viewed in the frontal plane. Additionally, edge stability is not assessed. In some cases, the occupant will benefit from the stability provided by the cushion's edge (i.e. a strengthened edge could be of benefit in supporting the required functional posture while the occupant is seated on the cushion). In other cases, the occupant could prefer lesser stability at the edge to assist in transferring off the cushion.

iTeh STANDARD PREVIEW
(standards.iteh.ai)

ISO 16840-13:2021

<https://standards.iteh.ai/catalog/standards/sist/5601d4f0-f53c-4359-a415-59f5a283ecda/iso-16840-13-2021>

Wheelchair seating —

Part 13:

Determination of the lateral stability property of a seat cushion

1 Scope

This document specifies apparatus, test methods, and disclosure requirements for determination of lateral stability properties of wheelchair seat cushions by measuring the response from the cushion to a shift in the centre of mass of the load on the cushion. It provides a method of determining changes in a particular physical and mechanical property of the cushion. It does not provide information specific to cushion performance for a particular individual user. It does not provide information related to anterior-posterior stability, nor to stability contributions from cushion edges.

NOTE 1 Test conditions simulate a symmetric anatomy.

NOTE 2 Loads are intended to represent those seen under the pelvis of a 40th to 60th percentile wheelchair user.

This document is applicable to cushions used in situations other than a wheelchair.

iTeh STANDARD PREVIEW
(standards.iteh.ai)

2 Normative references

ISO 16840-13:2021

The following documents are referred to in the text in such a way that some or all of their content constitutes requirements of this document. For dated references, only the edition cited applies. For undated references, the latest edition of the referenced document (including any amendments) applies.

ISO 7176-26, *Wheelchairs — Part 26: Vocabulary*

ISO 16840-2:2018, *Wheelchair seating — Part 2: Determination of physical and mechanical characteristics of seat cushions intended to manage tissue integrity*

3 Terms and definitions

For the purposes of this document, the terms and definitions given in ISO 16840-2 and ISO 7176-26 and the following apply.

ISO and IEC maintain terminological databases for use in standardization at the following addresses:

— ISO Online browsing platform: available at <https://www.iso.org/obp>

— IEC Electropedia: available at <http://www.electropedia.org/>

3.1

cushion lateral stability

cushion's ability to resist tilting of the pelvis as viewed in the frontal plane caused by a shifting centre of mass of occupant in a lateral direction

3.2 cushion stability test live load

portion of the total apparatus weight applied to the test cushion that translates in the horizontal plane to shift the centre of mass of the load relative to the test cushion during the test procedure

Note 1 to entry: Example of a live load are keys 4, 5 and 6 of [Figure 1](#).

3.3 cushion stability test dead load

portion of the total apparatus weight applied to the test cushion that does not translate in the horizontal plane relative to the test cushion during the test procedure

Note 1 to entry: Example of a dead load are keys 7 and 8 of [Figure 1](#).

4 Abbreviations

RCLI Rigid Cushion Loading Indenter

5 Apparatus

5.1 RCLI

An RCLI as specified in ISO 16840-2:2018, Annex A and D.

5.2 RCLI cover

There shall be a denim material cover between the RCLI and the cushion.

Medium-weight (272 g/m² to 465 g/m²) 100% cotton denim fabric per ASTM D6554/D6554 M – 14 is recommended as the covering material. Thread characteristic and weave technique will vary across fabrics, lots, years, and manufacturers, and will result in variation of frictional properties.

NOTE The cover is used to increase the coefficient of friction between the cushion and the RCLI and thus prevent the RCLI from slipping out from between the cushion and live load during the test procedure.

5.3 Stability test rig

A means of applying a vertical load as specified in ISO 16840-2:2018, Annex D to a cushion where the load is divided into a cushion stability test live load of 60 % ± 1 % of the total load and an unconstrained cushion stability test dead load of 40 % ± 1 % of the total load placed on its top surface. The dead load consists of the appropriate sized RCLI with secured added weight (if necessary) distributed uniformly on its top surface. [Figure 1](#) shows an example of a stability test rig.

A live load is attached to the rig and configured such that it can be applied on the top surface of the dead load and translated in the lateral direction relative to the base plate. The live load shall have the ability to be initially applied and held at an anterior-posterior location as specified in ISO 16840-2:2018, Annex A and D along the medial-lateral centre line of the cushion, and then displaced and held 75 mm from the centre line in the lateral direction via a rolling mechanism. The live load shall be able to rotate around and translate along the vertical axis.

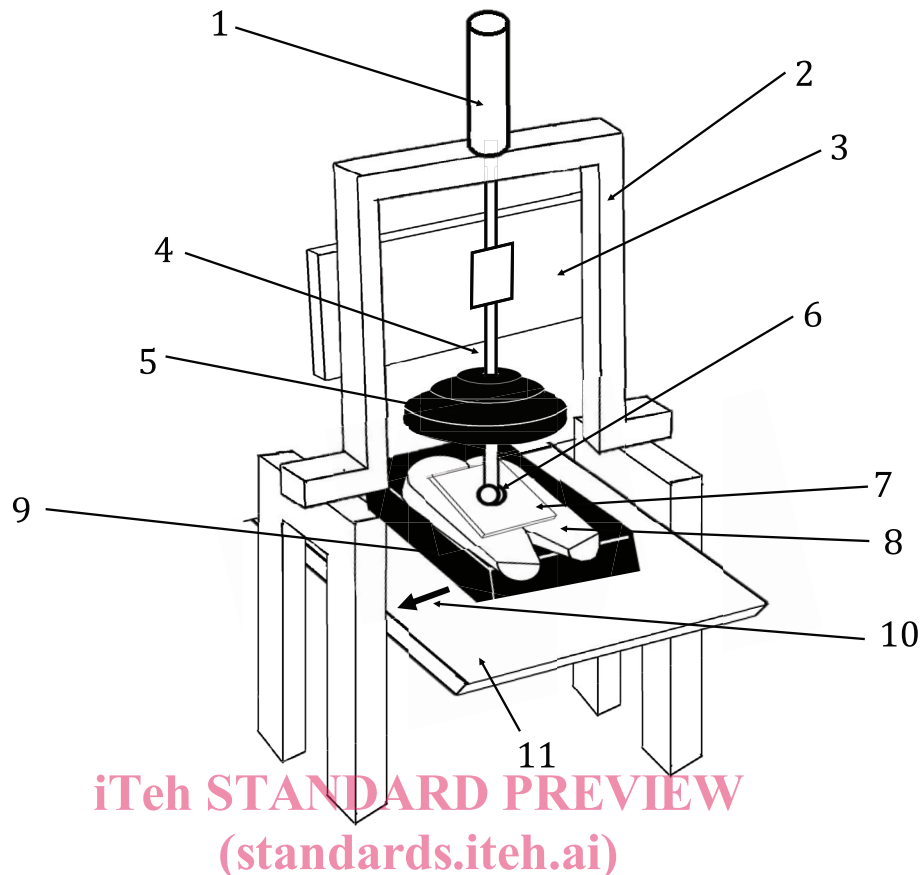

iTeh STANDARD PREVIEW
(standards.iteh.ai)

Key

- | | | | |
|---|-----------------------------------|----|--|
| 1 | actuator (to apply load) | 7 | known load (portion of dead load such as low profile metal plate fixed to the top surface of the RCLI to meet load requirements) |
| 2 | frame | 8 | RCLI (portion of dead load) with denim cover |
| 3 | vertical rod constraint | 9 | test cushion |
| 4 | solid rod (portion of live load) | 10 | source of lateral movement |
| 5 | known load (portion of live load) | 11 | base plate |
| 6 | a roller mechanism | | |

NOTE Elements 1, 2, 3, 4, 6, or 10 can be achieved by any means.

Figure 1 — Example of a Stability Test Rig

5.4 Tilt angle measurement device

A means of measuring the tilt angle of the RCLI dead load to within $\pm 0,1^\circ$ in the medial-lateral and anterior-posterior directions.

6 Test environment

An environment with ambient temperature of $23\text{ }^\circ\text{C} \pm 2\text{ }^\circ\text{C}$ and relative humidity of $50\% \pm 5\%$, as specified in ISO 554, shall be employed. This document does not attempt to address all safety concerns. Always utilize appropriate safety equipment and conditions.

7 Preparation and setup of cushion

7.1 Choice of cushion

Obtain an unused sample seat cushion for testing. If a cover is provided, ensure that the cover is fitted to the cushion in the orientation specified by the manufacturer.

7.2 Preconditioning the cushion

Precondition and setup the seat cushion prior to each test as specified in ISO 16840-2:2018, 6.2 and 6.3.

8 Cushion lateral stability test method

8.1 General

The method presented in this document is intended to evaluate how a wheelchair cushion resists a moment at the pelvis. Moments in the test method are created by shifting a vertical load laterally on the top surface of a standard RCLI simulating the buttocks and upper thighs. The magnitude of tilt of the RCLI in the frontal plane is quantified. This tilt is referred to as lateral tilt in this document. Lateral tilt is associated with lateral stability.

NOTE Pressure mapping between the RCLI and the cushion can be used to augment the test by quantifying the distribution of the forces resisting the tendency to tilt. A method for adding the pressure mapping procedure can be found in [Annex A](#).

8.2 Test procedure

- a) Secure the test cushion to the base plate ~~without constraining~~ the cushion sides.

NOTE A hook and loop fastening strip or restraint bar along the edge of the cushion base are effective means of constraining the cushion on the test base

- b) Select an appropriately sized RCLI from ISO 16840-2:2018, Annex A and D depending on the cushion size. RCLI specifications for testing various cushion sizes, applied load magnitudes and point of load application are provided in these annexes.
- c) Place the dead load on top of cushion such that the base points of the RCLI are positioned 125 mm ± 25 mm from the rear of the cushion or at a location appropriate for the contour of the cushion.
- d) Apply the live load at the anterior-posterior location specified in ISO 16840-2:2018, Annex A and D along the centre line as specified in [5.3](#).
- e) Adjust the dead load by moving its position under the live load to a neutral position such that its top surface is horizontal within ±0,3° in the medial-lateral direction without changing the point of live load application. Achieving baseline orientation within ±0,3° of the horizontal plane might not be possible for highly contoured cushions. If this tolerance cannot be achieved, note a deviation in the test report.
- f) Adjust the dead load by moving its position under the live load to a neutral position such that its top surface is as close to horizontal as possible in the anterior-posterior direction without changing the point of live load application.
- g) Allow at least 60 s for the cushion to adjust to the changes in the load after reaching the final orientation.
- h) Record baseline (neutral) tilt angles in the medial-lateral, $\theta_{m,l}^0$, and anterior-posterior, $\theta_{a,p}^0$, directions.