

FINAL
DRAFT

INTERNATIONAL
STANDARD

ISO/FDIS
7320

ISO/TC 20/SC 10

Secretariat: DIN

Voting begins on:
2021-03-03

Voting terminates on:
2021-04-28

Aerospace — Couplings, threaded and sealed, for fluid systems — Dimensions

*Aéronautique et espace — Raccordement fileté étanche pour les
systèmes de fluides — Dimensions*

iTeh STANDARD PREVIEW
(standards.iteh.ai)

[ISO/FDIS 7320](https://standards.iteh.ai/catalog/standards/sist/a3d68b95-7a58-4830-9a0c-059990233b04/iso-fdis-7320)

<https://standards.iteh.ai/catalog/standards/sist/a3d68b95-7a58-4830-9a0c-059990233b04/iso-fdis-7320>

RECIPIENTS OF THIS DRAFT ARE INVITED TO SUBMIT, WITH THEIR COMMENTS, NOTIFICATION OF ANY RELEVANT PATENT RIGHTS OF WHICH THEY ARE AWARE AND TO PROVIDE SUPPORTING DOCUMENTATION.

IN ADDITION TO THEIR EVALUATION AS BEING ACCEPTABLE FOR INDUSTRIAL, TECHNOLOGICAL, COMMERCIAL AND USER PURPOSES, DRAFT INTERNATIONAL STANDARDS MAY ON OCCASION HAVE TO BE CONSIDERED IN THE LIGHT OF THEIR POTENTIAL TO BECOME STANDARDS TO WHICH REFERENCE MAY BE MADE IN NATIONAL REGULATIONS.



Reference number
ISO/FDIS 7320:2021(E)

© ISO 2021

iTeh STANDARD PREVIEW
(standards.iteh.ai)

ISO/FDIS 7320

<https://standards.iteh.ai/catalog/standards/sist/a3d68b95-7a58-4830-9a0c-059990233b04/iso-fdis-7320>



COPYRIGHT PROTECTED DOCUMENT

© ISO 2021

All rights reserved. Unless otherwise specified, or required in the context of its implementation, no part of this publication may be reproduced or utilized otherwise in any form or by any means, electronic or mechanical, including photocopying, or posting on the internet or an intranet, without prior written permission. Permission can be requested from either ISO at the address below or ISO's member body in the country of the requester.

ISO copyright office
CP 401 • Ch. de Blandonnet 8
CH-1214 Vernier, Geneva
Phone: +41 22 749 01 11
Email: copyright@iso.org
Website: www.iso.org

Published in Switzerland

Contents

	Page
Foreword	iv
1 Scope	1
2 Normative references	1
3 Terms and definitions	1
4 Sealing principle and assembly of the coupling	1
5 Dimensions	1
5.1 Port connection	1
5.2 Fitting end	3
5.3 O-ring seal	5
Bibliography	7

iTeh STANDARD PREVIEW (standards.iteh.ai)

ISO/FDIS 7320

<https://standards.iteh.ai/catalog/standards/sist/a3d68b95-7a58-4830-9a0c-059990233b04/iso-fdis-7320>

Foreword

ISO (the International Organization for Standardization) is a worldwide federation of national standards bodies (ISO member bodies). The work of preparing International Standards is normally carried out through ISO technical committees. Each member body interested in a subject for which a technical committee has been established has the right to be represented on that committee. International organizations, governmental and non-governmental, in liaison with ISO, also take part in the work. ISO collaborates closely with the International Electrotechnical Commission (IEC) on all matters of electrotechnical standardization.

The procedures used to develop this document and those intended for its further maintenance are described in the ISO/IEC Directives, Part 1. In particular, the different approval criteria needed for the different types of ISO documents should be noted. This document was drafted in accordance with the editorial rules of the ISO/IEC Directives, Part 2 (see www.iso.org/directives).

Attention is drawn to the possibility that some of the elements of this document may be the subject of patent rights. ISO shall not be held responsible for identifying any or all such patent rights. Details of any patent rights identified during the development of the document will be in the Introduction and/or on the ISO list of patent declarations received (see www.iso.org/patents).

Any trade name used in this document is information given for the convenience of users and does not constitute an endorsement.

For an explanation of the voluntary nature of standards, the meaning of ISO specific terms and expressions related to conformity assessment, as well as information about ISO's adherence to the World Trade Organization (WTO) principles in the Technical Barriers to Trade (TBT), see www.iso.org/iso/foreword.html.

This document was prepared by Technical Committee ISO/TC 20, *Aircraft and space vehicles*, Subcommittee SC 10, *Aerospace fluid systems and components*.

This third edition cancels and replaces the second edition (ISO 7320:1992), of which it constitutes a minor revision.

The main changes compared to the previous edition are as follows:

- the normative reference has been changed from dated to undated.

Any feedback or questions on this document should be directed to the user's national standards body. A complete listing of these bodies can be found at www.iso.org/members.html.

Aerospace — Couplings, threaded and sealed, for fluid systems — Dimensions

1 Scope

This document establishes a system for sealing the port connection of couplings used in the aerospace industry.

It specifies dimensions to achieve interchangeability of the port connection, the fitting end and a seal. The seal can be a standard O-ring or a special ring.

2 Normative references

The following documents are referred to in the text in such a way that some or all of their content constitutes requirements of this document. For dated references, only the edition cited applies. For undated references, the latest edition of the referenced document (including any amendments) applies.

ISO 5855-3, *Aerospace — MJ threads — Part 3: Limit dimensions for fittings for fluid systems*

3 Terms and definitions

No terms and definitions are listed in this document.

ISO and IEC maintain terminological databases for use in standardization at the following addresses:

- ISO Online browsing platform: available at <https://www.iso.org/obp>
- IEC Electropedia: available at <http://www.electropedia.org/>

4 Sealing principle and assembly of the coupling

The coupling comprises three elements:

- a) the port element, including the internal thread (see [5.1](#));
- b) the fitting element, including an external thread and a groove intended to receive the O-ring (see [5.2](#)) or a special seal; this element is screwed into the internal threaded element;
- c) the seal element, which maintains system pressure without leakage [a standard O-ring (see [5.3](#)) or special seal].

5 Dimensions

5.1 Port connection

See [Figure 1](#) and [Table 1](#).

Dimensions in millimetres
 Surface roughness values in micrometres
 Remove burrs 0,1 to 0,4, unless otherwise specified

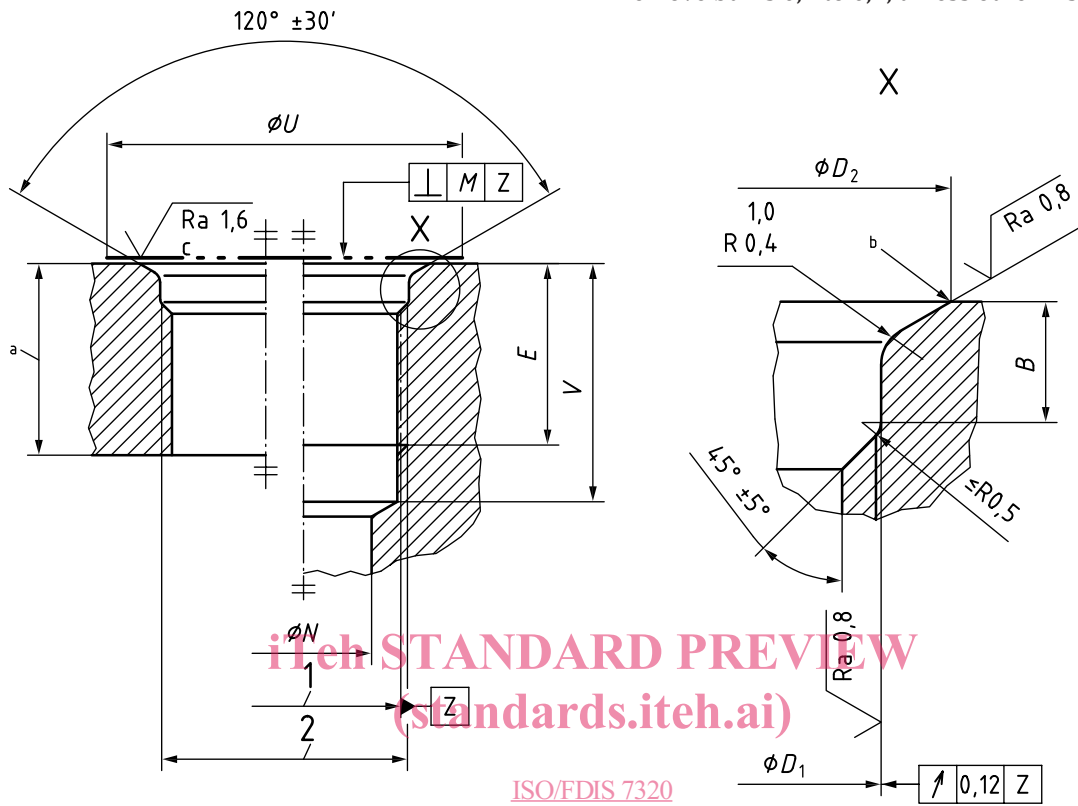

STANDARD PREVIEW
 (standards.iteh.ai)
 ISO/FDIS 7320
<https://standards.iteh.ai/catalog/standards/sist/a3d68b95-7a58-4830-9a0c-059990233b04/iso-fdis-7320>

Key

- 1 pitch diameter
- 2 thread
- a Height to suit design (min. = E).
- b Break edge 0,15 max.

Figure 1 — Port connection configuration

Table 1 — Port connection dimensions

Dimensions in millimetres

DN ^a	Thread ^b 4H5H	B +0,4 0	D ₁		D ₂ +0,4 0	E min.	M	N min.	U min.	V max.					
			nom.	tol.											
03	MJ8 × 1	1,9	8,6	+0,1 0	11,3	11	0,08	Internal diameter of tube	15	15					
04			10,6		13,3				18						
05			MJ10 × 1		12,4				15,1		12,5	20	17		
06	MJ12 × 1,25	3,4	14,6	+0,15 0	18,3	16	0,1	Internal diameter of tube	23	21					
08	MJ14 × 1,5		16,6		20,3				25						
10	MJ16 × 1,5		18,6		22,3				28						
12	MJ18 × 1,5		20,6		24,3				31						
14	MJ20 × 1,5		22,6		26,3				33						
16	MJ22 × 1,5		24,6		28,3				37						
18	MJ24 × 1,5		27,6		31,3				42						
20	MJ27 × 1,5		30,6		34,3				47						
22	MJ30 × 1,5		33,6		37,3				56						
25	MJ33 × 1,5		36,6		40,3				61						
28	MJ36 × 1,5		4,3		43				20		0,2	0,2	Internal diameter of tube	56	26
32	MJ42 × 2				47,1									56	
40	MJ50 × 2				51									55,1	

^a DN = Nominal size (outside diameter of the corresponding tube)

^b Threads shall be in accordance with ISO 5855-3.

ISO/FDIS 7320

5.2 Fitting end

<https://standards.iteh.ai/catalog/standards/sist/a3d68b95-7a58-4830-9a0c-059990233b04/iso-fdis-7320>

See [Figure 2](#) and [Table 2](#).

Dimensions in millimetres
 Surface roughness values in micrometres
 Remove burrs 0,1 to 0,4, unless otherwise specified

X

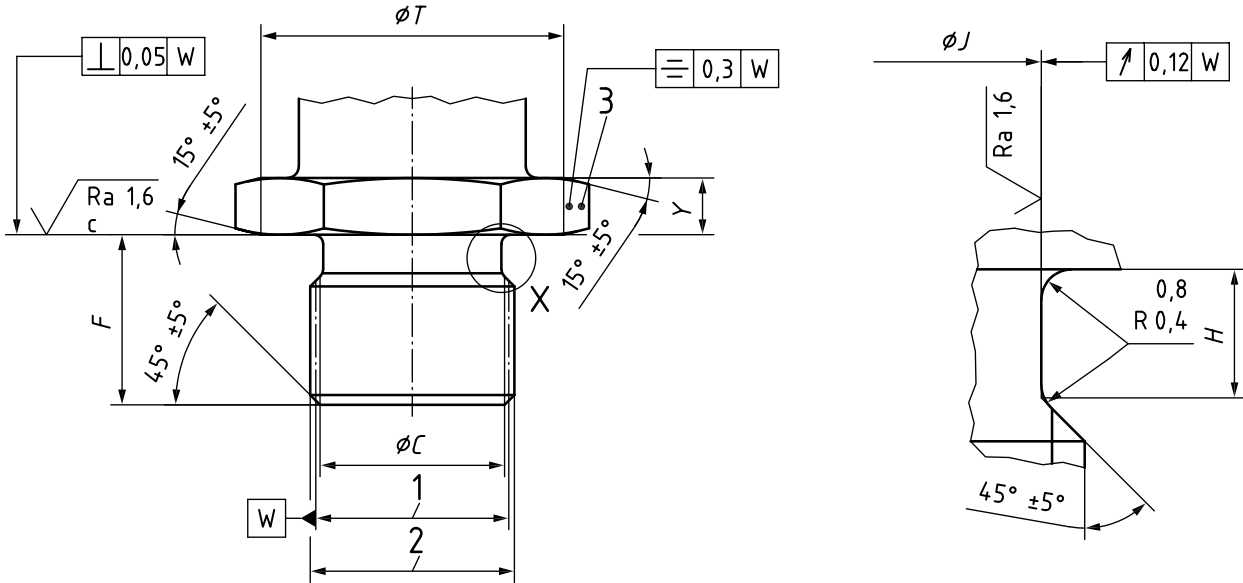

Key

- 1 pitch diameter
- 2 thread
- 3 S, across flats

iTeh STANDARD PREVIEW
 (standards.iteh.ai)

ISO/FDIS 7320

[https://standards.iteh.ai/catalog/standards/sist/a3d68b95-7a58-4830-9a0c-](https://standards.iteh.ai/catalog/standards/sist/a3d68b95-7a58-4830-9a0c-059990233b04/iso-fdis-7320)

[059990233b04/iso-fdis-7320](https://standards.iteh.ai/catalog/standards/sist/a3d68b95-7a58-4830-9a0c-059990233b04/iso-fdis-7320)

Figure 2 — Fitting end configuration

Table 2 — Fitting end dimensions

Dimensions in millimetres

DN ^a	Thread ^b 4h6h	C ±0,5	F 0 -0,2	H +0,4 0	J		S		T +0,5 0	Y min.																		
					nom.	tol.	nom.	tol.																				
03	MJ8 × 1	6,2	10	1,9	6,3	0 -0,08	14	h13	13,8	3																		
04					8,3		17		16,8																			
05					10,1		19		18,7																			
06	MJ12 × 1,25	9,8	11,5	15	3,4	0 -0,15	22	h14	21,7	4																		
08	MJ14 × 1,5	11,5	15				3,4		0 -0,15		24	h14	23,7	5														
10	MJ16 × 1,5	13,5									27		h14		26,7													
12	MJ18 × 1,5	15,5									30				h14	29,7												
14	MJ20 × 1,5	17,5									32					h14	31,6											
16	MJ22 × 1,5	19,5									36						h14	35,4										
18	MJ24 × 1,5	21,5									41							h14	40,4									
20	MJ27 × 1,5	24,5									46								h14	45,4								
22	MJ30 × 1,5	27,5									50									h14	49,4							
25	MJ33 × 1,5	30,5									55										h14	54,4						
28	MJ36 × 1,5	33,5									60											h14	59,3					
32	MJ42 × 2	38,9									19												4,3	39	0	50	49,4	6
40	MJ50 × 2	46,9									19												4,3	47	0	60	59,3	

^a DN = Nominal size (outside diameter of the corresponding tube)

^b Threads shall be in accordance with ISO 5855-3.

ISO/FDIS 7320

5.3 O-ring seal

<https://standards.iteh.ai/catalog/standards/sist/a3d68b95-7a58-4830-9a0c-059990233b04/iso-fdis-7320>

See Figure 3 and Table 3.

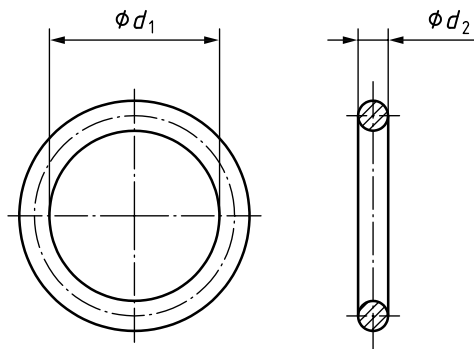

Figure 3 — O-ring seal configuration

Table 3 — Selection of O-ring seal sizes

Dimensions in millimetres

DN ^a	d_1		d_2	
	nom.	tol.	nom.	tol.
03	6	± 0,13	1,8	±0,08
04				
05				
06				
08	11,2	± 0,16	2,65	±0,09
10				
12				
14				
16				
18				
20				
22				
25				
28				
32				
40				
NOTE Selection taken from Series A of ISO 3601-1.				
^a DN = Nominal size (outside diameter of the corresponding tube).				

ISO/FDIS 7320

<https://standards.iteh.ai/catalog/standards/sist/a3d68b95-7a58-4830-9a0c-059990233b04/iso-fdis-7320>