



Designation: D7420 – 11

Standard Test Method for Determining Tribomechanical Properties of Grease Lubricated Plastic Socket Suspension Joints Using a High- Frequency, Linear-Oscillation (SRV) Test Machine¹

This standard is issued under the fixed designation D7420; the number immediately following the designation indicates the year of original adoption or, in the case of revision, the year of last revision. A number in parentheses indicates the year of last reapproval. A superscript epsilon (ϵ) indicates an editorial change since the last revision or reapproval.

INTRODUCTION

This test method was originally published as bilingual company standard TRW 62 051 301 in June 2002. TRW Fahrwerksysteme² transferred the copyright on Oct. 5, 2004 to standardization bodies. The DIN 51834 working group has modified this standard by adding precision information based on round robin tests.

1. Scope*

1.1 This test method covers a procedure for determining the friction and wear behavior of grease lubricated plastic socket suspension joints, for validation of suspension joint greases and quality inspection for those greases under high-frequency linear-oscillation motion using the SRV test machine.

1.2 The values stated in SI units are to be regarded as standard. No other units of measurement are included in this standard.

1.3 *This standard does not purport to address all of the safety concerns, if any, associated with its use. It is the responsibility of the user of this standard to establish appropriate safety and health practices and determine the applicability of regulatory limitations prior to use.*

2. Referenced Documents

2.1 ASTM Standards:³

[A295 Specification for High-Carbon Anti-Friction Bearing Steel](#)

[D217 Test Methods for Cone Penetration of Lubricating Grease](#)

[D4175 Terminology Relating to Petroleum, Petroleum Products, and Lubricants](#)

[D5706 Test Method for Determining Extreme Pressure Properties of Lubricating Greases Using a High-Frequency, Linear-Oscillation \(SRV\) Test Machine](#)

[E45 Test Methods for Determining the Inclusion Content of Steel](#)

[G40 Terminology Relating to Wear and Erosion](#)

2.2 DIN Standards:⁴

[DIN 51631:1999 Special-boiling-point spirits - Requirements and testing](#)

[DIN EN 10025-1:2005 Hot rolled products of structural steels - Part 1: General technical delivery conditions](#)

[DIN EN ISO 683-17 Heat-treated steels, alloy steels and free-cutting steels - Part 17: Ball and roller bearing steels \(replaces DIN 17230-1980\)](#)

[DIN EN ISO 13565-2:1998 Geometrical Product Specifications \(GPS\) - Surface texture: Profile method - Surfaces having stratified functional properties - Part 2: Height characterization using the linear material ratio curve](#)

3. Terminology

3.1 Definitions:

3.1.1 *break-in, n—in tribology*, an initial transition process occurring in newly established wearing contacts, often accompanied by transients in coefficient of friction or wear rate, or both, which are uncharacteristic of the given tribological system's long-term behavior. **G40**

¹ This test method is under the jurisdiction of ASTM Committee D02 on Petroleum Products, Liquid Fuels, and Lubricants and is the direct responsibility of Subcommittee D02.G0 on Lubricating Grease.

Current edition approved Dec. 1, 2011. Published March 2012. Originally approved in 2010. Last previous edition approved in 2010 as D7420-10. DOI:10.1520/D7420-11.

² TRW Fahrwerksysteme (Chassis Systems), D-50543, Düsseldorf, Germany.

³ For referenced ASTM standards, visit the ASTM website, www.astm.org, or contact ASTM Customer Service at service@astm.org. For *Annual Book of ASTM Standards* volume information, refer to the standard's Document Summary page on the ASTM website.

⁴ Available from Beuth Verlag GmbH (DIN-- DIN Deutsches Institut für Normung e.V.), Burggrafenstrasse 6, 10787, Berlin, Germany, http://www.en.din.de.

*A Summary of Changes section appears at the end of this standard

3.1.2 *coefficient of friction, μ or f , n* —in tribology, the dimensionless ratio of the friction force (F) between two bodies to the normal force (N) pressing these bodies together.

G40

3.1.3 *lubricant, n* —any material interposed between two surfaces that reduces the friction or wear between them.

D4175

3.1.4 *lubricating grease, n* —a semi-fluid to solid product of a dispersion of a thickener in a liquid lubricant.

D217

3.1.4.1 *Discussion*—The dispersion of the thickener forms a two-phase system and immobilizes the liquid lubricant by surface tension and other physical forces. Other ingredients are commonly included to impart special properties.

3.1.5 *nitro-carburization, n* —nitro-carburizing is not defined in the ASTM Dictionary of Engineering Science and Technology, but is defined in DIN EN 10025-1:2005.

3.1.6 *Ra (C.L.A.), n* —in measuring surface finish, the arithmetic average of the absolute distances of all profile points from the mean line for a given distance.

Amstutz⁵

3.1.7 *Rpk, n* —Reduced peak height according to DIN EN ISO 13565-2:1998. *Rpk* is the mean height of the peak sticking out above the core profile section.

3.1.8 *Rvk, n* —Reduced valley height according to DIN EN ISO 13565-2:1998. *Rvk* is the mean depth of the valley reaching into the material below the core profile section.

3.1.9 *Rz (DIN), n* —in measuring surface finish, the average of all Ry values (peak to valley heights) in the assessment length.

Amstutz⁶

3.1.10 *thickener, n* —in lubricating grease, a substance composed of finely divided particles dispersed in a liquid lubricant to form the product's structure.

D217

3.1.10.1 *Discussion*—The thickener can be fibers (such as various metallic soaps) or plates or spheres (such as certain non-soap thickeners) which are insoluble or, at most, only very slightly soluble in the liquid lubricant. The general requirements are that the solid particles be extremely small, uniformly dispersed, and capable of forming a relatively stable, gel-like structure with the liquid lubricant.

3.2 Definitions of Terms Specific to This Standard:

3.2.1 *metal specimen, n* —represented by the lower specimen. Ball stud or ball pins are also used as common synonym.

3.2.2 *plastic socket, n* —represented by the upper polymeric disk specimen. Plastic seat or beating is also used as common synonym.

3.2.3 *seizure, n* —localized fusion of metal between the rubbing surfaces of the test pieces.

D5706

3.2.3.1 *Discussion*—In this test method, seizure is indicated by a sharp rise in the coefficient of friction, over steady state, of greater than 0.2 for over 20 s. In severe cases, a stoppage in the motor will occur (for example, see Test Method **D5706**).

3.3 Abbreviations:

3.3.1 *SRV, n* —Schwingung, Reibung, Verschleiß (German); oscillating, friction, wear (English translation).

4. Summary of Test Method

4.1 This test method is performed on SRV test machine using a polymeric disk having three flat pins oscillating at 50 Hz against a steel test disk with lubricant (grease) between them. Test load is fixed to 2000 N using a test temperature of 50°C and a stroke of 1.5 mm during a test time of 2 h.

NOTE 1—Test frequency, stroke length, temperature, and polymeric disk and disk material can be varied to simulate field conditions. The polymeric disk having three flat pins yields surface-on-flat contact geometry.

NOTE 2—This test can not be executed with SRV I and SRV II models, as they are limited to 1200 N and 1400 N, respectively. The SRV III and SRV IV model are from the test chamber and operating conditions identical, but the SRV IV model allows to tilt and rotate the test chamber. Both are fully computer controlled. This test runs in the SRV IV models horizontally and untilted.

5. Significance and Use

5.1 This test method can be used to quickly determine the lubricating ability of greases lubricating automotive plastic socket suspension joints. This test method has found wide application in qualifying greases used in chassis systems. This test method is a material and application oriented approach based on inputs from field experiences for characterizing the tribological behavior (friction and wear) using random, discrete, and constant parameter combinations. Users of this test method should determine whether results correlate with field performance or other applications prior to commercialization.

6. Apparatus

6.1 *SRV Test Machine*,⁷—See **Fig. 1** and **Fig. 2**.

7. Reagents and Materials

7.1 *Polymeric Test Disk with Three Pins*, $\varnothing = 18.2^{+0.2}$ -mm diameter. Each pin has a diameter of $\varnothing = 3.0$ -mm (see **Fig. X1.1**). The plastic specimen should represent characteristic items of an inner plastic socket surface. Specimens are molded from original socket material; functional surfaces shall be free from scratches and any surface damages.

7.2 *Lower Test Disk*⁷—Vacuum arc remelted (VAR) AISI 52100 steel with a inclusion rating using Method D, Type A, as severity level number of 0.5 according to Test Methods **E45** and Specification **A295** or a inclusion sum value $K1 \leq 10$ according to DIN EN ISO 683-17 and spheroidized annealed to obtain globular carbide, 62 ± 1 HRC hardness, the surfaces of the disk being lapped and free of lapping raw materials. The topography of the disk will be determined by four values:

$0.5 \mu\text{m} < Rz < 0.650 \mu\text{m}$

$0.35 \mu\text{m} < \text{C.L.A. (Ra)} < 0.050 \mu\text{m}$

$0.020 \mu\text{m} < Rpk < 0.035 \mu\text{m}$

⁵ Amstutz, Hu, "Surface Texture: The Parameters," Bulletin MI-TP-003-0785, Sheffield Measurement Division, Warner and Swasey, 1985, p. 21

⁶ Amstutz, Hu, "Surface Texture: The Parameters", Bulletin MI-TP-003-0785, Sheffield Measurement Division, Warner and Swasey, 1985, pp. 29–31.

⁷ The sole source of supply of the apparatus known to the committee at this time is Optimol Instruments GmbH, Westendstr. 125, D-80339 Munich, Germany. If you are aware of alternative suppliers, please provide this information to ASTM International Headquarters. Your comments will receive careful consideration at a meeting of the responsible technical committee,¹ which you may attend.

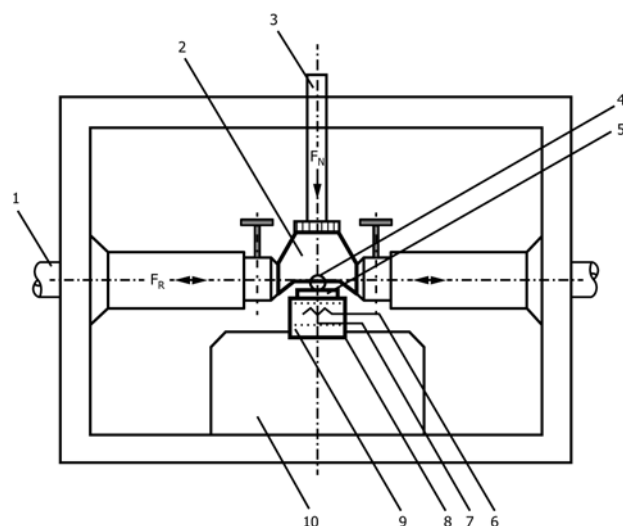

- | | |
|--------------------------|-----------------------------------|
| 1. Oscillation drive rod | 6. Electrical Resistance Heater |
| 2. Test Ball Holder | 7. Resistance Thermometer |
| 3. Load Rod | 8. Test Disk Holder |
| 4. Test Ball | 9. Piezoelectric Measuring Device |
| 5. Test Disk | 10. Receiving Block |

FIG. 2 Test Chamber Elements (Schematic) of SRV Test Machine

knowledge of the material to be tested, or by the recommendation of the supplier.)

7.4 *Cleaning Solvent*, Special boiling point spirit type 2-A in accordance with DIN 51631. (**Warning**—Flammable. Health hazard.)

8. Preparation of Apparatus

8.1 *SRV Machine Generation III and IV*—Turn on the test machine and the computer, and allow them to warm up for 15 min prior to running tests.

9. Procedure

9.1 Check the polymeric disk for visible damage or scratches. Clean the polymeric disk and the steel disk by wiping the surfaces with laboratory tissue soaked with the cleaning solvent. Repeat wiping until no dark residue appears on the tissue. Immerse the steel disk in a beaker of the cleaning solvent under ultrasonic vibration for 10 min. Dry the steel test disk with a clean tissue to ensure no streaking occurs on the surface. Generally, a new specimen should be used for each test.

NOTE 4—Ensure that the polymer and the constituents of the blend is resistant to the solvent. If the binder is not resistant to the solvent, wipe only the polymeric disk surface with a laboratory tissue.

9.2 Prior to testing, determine thickness of plastic specimen in all three contact surfaces (pins) by a micrometer gauge caliper rule. Document measurement readings in the test report.

9.3 Place the grease using a calibration ring while ensuring that the grease is applied to a height of 0.2-0.3 mm above the metal test disk.



NOTE 1—Above: Model III; Below: Model IV

FIG. 1 SRV Test Machine

$0.050 \mu\text{m} < R_{vk} < 0.075 \mu\text{m}$ (24 ± 0.5 -mm diameter by 7.8 ± 0.1 -mm thick)

If other surface roughnesses are applied, they have to be measured and stated in the report. The type of coating and/or thermomechanical treatment has to be reported.

NOTE 3—The steel 41CrS4 (DIN 1.7039) is also used in practice. The test disks should be polished to R_z 1-1.5 μm and can be carbo-nitrided.

7.3 *Grease*, Store in a sealed container prior to testing. (Different greases have different characteristics for storage stability and shelf life and users should be guided by their own