



Standard Specification for Selectorized Strength Equipment¹

This standard is issued under the fixed designation F2216; the number immediately following the designation indicates the year of original adoption or, in the case of revision, the year of last revision. A number in parentheses indicates the year of last reapproval. A superscript epsilon (ϵ) indicates an editorial change since the last revision or reapproval.

INTRODUCTION

The goal of this specification is to promote proper design and manufacturing practices for selectorized strength training equipment. Through these specifications, this specification aims to assist designers and manufacturers in reducing the possibility of injury when these products are used in accordance with the operational instructions.

The equipment user must recognize, however, that a standard alone will not necessarily prevent injuries. Like other physical activities, exercise involving selectorized strength training equipment involves the risk of injury, particularly if the equipment is used improperly or not properly maintained. In addition, users with physical limitations should seek medical advice and instruction from the fitness facility prior to using this equipment. Certain physical conditions or limitations may preclude some persons from using this equipment properly and without increasing the risk of serious injury.

1. Scope

1.1 This specification establishes parameters for the design and manufacture of selectorized strength training equipment as defined in 3.1.

1.2 It is intended that these fitness products be used in an indoor setting or environment.

1.3 It is the intent of this standard to specify fitness products for use only by individuals age 13 and older.

1.4 This standard is to be used in conjunction with Specification F2276, Test Methods F2571, and Test Method F2277.

1.5 This standard takes precedence over Specification F2276 and Test Methods F2571 in areas that are specific or unique to selectorized strength training equipment.

1.6 The values stated in SI units are to be regarded as the standard. The values in parentheses are for information only.

1.7 *This standard does not purport to address all of the safety concerns, if any, associated with its use. It is the responsibility of the user of this standard to establish appropriate safety and health practices and determine the applicability of regulatory limitations prior to use.*

2. Referenced Documents

2.1 *ASTM Standards:*²

F1749 Specification for Fitness Equipment and Fitness Facility Safety Signage and Labels

F2276 Specification for Fitness Equipment

F2277 Test Methods for Evaluating Design and Performance Characteristics of Selectorized Strength Equipment

F2571 Test Methods for Evaluating Design and Performance Characteristics of Fitness Equipment

3. Terminology

3.1 *Definitions:*

3.1.1 *assist means, n*—mechanism that the user engages on the machine to assist them in getting into and out of the loaded starting position.

3.1.2 *cam, n*—rotational component controlling the resistance to the user.

3.1.3 *catch point, n*—location at which edges, protrusions, or surfaces allow a body part to become injured.

3.1.4 *consumer selectorized strength equipment, n*—selectorized strength equipment intended for home use or for use in a home environment.

3.1.4.1 *Discussion*—Since significant differences can arise between consumer and institutional selectorized strength equipment, the products must be clearly identified as not for commercial use.

¹ This specification is under the jurisdiction of ASTM Committee F08 on Sports Equipment, Playing Surfaces, and Facilities and is the direct responsibility of Subcommittee F08.30 on Fitness Products.

Current edition approved March 1, 2012. Published March 2012. Originally approved in 2003. Last previous edition approved in 2005 as F2216 – 05. DOI: 10.1520/F2216-12.

² For referenced ASTM standards, visit the ASTM website, www.astm.org, or contact ASTM Customer Service at service@astm.org. For *Annual Book of ASTM Standards* volume information, refer to the standard's Document Summary page on the ASTM website.

3.1.5 *field of view, n*—field of view of the user defined by an arc of 150°. Seventy-five degrees on each side of the median plane.

3.1.6 *foot support, n*—machine component(s) contacting the user’s feet during operation, entry, and exit from the machine.

3.1.7 *institutional strength equipment, n*—strength equipment intended for use by numerous persons in a commercial or institutional facility, as opposed to home environment.

3.1.8 *median plane, n*—plane of reference that divides the midline of the body of the user into equal right and left halves.

3.1.9 *rope, n*—for the purpose of this specification, a cord comprised of intertwisted synthetic or natural fibers or steel wires used for the transmittal of load from the resistance means to the user means.

3.1.10 *selector pin, n*—the component used to select resistance on weight based selectorized strength equipment.

3.1.11 *selectorized strength equipment, n*—strength equipment where the resistance means is an integral part of the machine and may be varied easily by the user.

3.1.12 *strength equipment, n*—fitness equipment designed to strengthen one or more groups of muscles anaerobically.

3.1.13 *user means, n*—movable component or assembly that the user contacts to perform the exercise.

3.1.14 *user support means, n*—portion of the machine (seat, platform, etc.) that supports the user while the user is performing the exercise.

4. General Requirements

4.1 Construction:

4.1.1 *Weights*—Weights shall move only when displaced intentionally. Weights shall move freely along their guide means and return to the resting point. The travel of the weights shall be controlled by the user such that no uncontrolled pendulum swing shall occur.

4.1.2 *Weight Selection Pin*—Weight selection pins shall be fitted with a positive retention means.

4.1.3 *Machine Ingress and Egress*—If the user cannot (after adjusting the machine according to the manufacturer’s instructions) attain the loaded starting position for the machine, then the machine shall be provided with an assist means.

4.1.4 *Ropes, Belts, Chains, or Other Means*—Ropes, belts, chains, and other means, including all attachment devices (links, shackles, end fittings, and termination means) shall not fail with a load equal to six times the maximum static tension developed by the machine during operation and shall pass the endurance guidelines set forth in 4.4.1. All end terminations shall not be subjected to cyclic bending under normal machine operation as defined by the manufacturer.

4.1.5 *Pulleys*—Pulleys for rope/belt drive machines shall rotate freely under all extrinsic loads.

4.1.5.1 *Wire Rope Pulleys*—The groove radius, *r*, of the pulley for wire rope driven machines shall meet the wire rope manufacturer’s guidelines, allow for passing of the endurance guidelines set forth in 4.5.3 or lie within the range given by the following equation, or both:

$$\frac{C_d}{2} + 5\% \text{ to } \frac{C_d}{2} + 15\% \tag{1}$$

with $C_d/2 + 10\%$ being the optimum. C_d is defined as the nominal wire rope diameter including coating. The tread diameter, *d*, of the pulley shall be a minimum of 18 times greater than the bare wire rope diameter (without coating). See Fig. 1.

4.1.5.2 *Belt Pulleys*—The diameter of the pulley shall be of sufficient size to yield a belt life meeting the parameters specified in 4.4.1. Belt pulleys shall be designed to prevent disengagement.

4.1.6 *Rope/Belt Guards*—Disengagement of ropes/belts shall be prevented by the provision of adequate retention guards or enclosures.

4.2 Entrapment Points:

4.2.1 *General Comments*—Unlike other machinery, selectorized strength equipment is fully controlled by the user of the equipment. It is therefore assumed that the user shall take responsibility for his/her actions while using the machine and can prevent the inadvertent contact with machine components within the user’s field of view by the user or a third party by stopping the exercise or movement of the machine. For this reason, the discussion of entrapment points is broken down into “within” and “outside” the field of view of the user. Wherever possible, the design of movable components shall avoid catch, shear, or pull-in points.

4.2.1.1 In general, the fingers are the body components most likely to be injured. The primary exception to this is weight stacks where feet or hands, or both, could also be injured. Weight stacks shall be spaced less than 9.5 mm (0.375 in.) or greater than 25 mm (0.98 in.) from any fixed frame member. This spacing shall remain constant through the travel range of

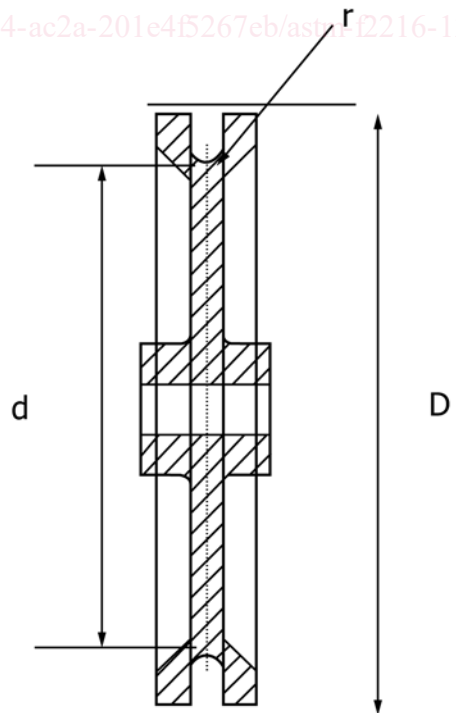

FIG. 1 Wire Rope Pulley Profile

the weight stack. Weight stacks shall be spaced at least 25 mm (0.98 in.) from the base frame of the machine. Strength equipment that includes weight stack enclosures designed in accordance with 4.3 as a permanent feature of the machine are exempt from this requirement, provided that the enclosure extends past the rest position of the bottom weight plate.

4.2.1.2 The user means or other moving components, or both, shall not pass within 60 mm (2.36 in.) of the moving weight stack during the normal operation of the machine, as defined in the instructions provided by the manufacturer. Mechanical stops are generally provided at one or both extremes of the user means range of travel. Since the user means will contact the stops at these locations, they are excluded from the clearance requirements. However, if the stop is physically part of the moving user means, then it shall pass no closer than 25 mm (0.98 in.) to any fixed frame members throughout its range of travel.

4.2.1.3 If the machine framework or the user’s body placement, while using the machine in accordance with the manufacturer’s instructions, prevents the uncontrolled access of a third party into the area of concern, then guarding is not required. The user’s body shall prevent access throughout the entire exercise range of motion.

4.2.2 *Outside the Field of View*—To a height of 1800 mm (70.8 in.), the distance between movable components or between a movable and fixed component shall be at least 60 mm (2.36 in.) when body parts other than the fingers are at risk. This dimension may be reduced to no less than 25 mm (0.98 in.) when only the fingers are at risk. If the spacing between moving components or between fixed and moving components remains constant throughout the range of motion of the machine, then the spacing shall be greater than 25 mm (0.98 in.) or less than 9.5 mm (0.375 in.). Guarding shall be provided if the design does not allow the above dimensions to be met.

4.2.3 *Within the Field of View and Within Reach of the User*—If distances do not conform to those specified in 4.2.2, the components shall be guarded or enclosed.

4.2.4 *Within the Field of View and Outside the Reach of the User*—Pinch and shear points within the user’s field of view but accessible only to a third party shall not be located within 25 mm (0.98 in.) of a stationary component. Alternatively, such points can be less than 9.5 mm (0.375 in.) from a stationary component if the spacing between the components remains constant throughout the range of movement of the machine.

4.2.5 *Pull-In Points*—Finger pull-in occurs when the spacing between the fixed and rotating component is less than 25 mm (0.98 in.) or when the angle between the fixed guard and the belt or rope is less than 50°, or both (see Fig. 2). For ropes and pulleys or ropes and cams, pull-in will occur during the portion of the exercise stroke that the rope wraps onto the rotating element or passes into the guard. This can occur on both sides of a pulley or guard as shown in Fig. 2 and Fig. 3. Fig. 4 illustrates a circular pulley or cam guard. To achieve a pull-in angle greater than 50°, the guard radius G_r shall be calculated using the following equation:

$$G_r > \left[\frac{d}{2} + \frac{C_d}{2} \right] / \cos 50^\circ \quad (2)$$

where d and C_d have been defined in 4.1.5.1 and 4.1.5.2.

4.2.5.1 *Outside the Field of View*—Pull-in points up to a height of 1800 mm (70.8 in.) shall be guarded or spaced greater than 25 mm (0.98 in.) apart so that the user’s or third party’s fingers, when extended, cannot be caught between the components (see Fig. 2). Rope, belt, or rope driven machines where the pressure between the rope/belt and the cam or pulley is less than 90 N/cm² (131 psi) are excluded from this requirement.

4.2.5.2 *Within the Field of View*—Pull-in points shall be guarded so that the user’s fingers, when extended from the

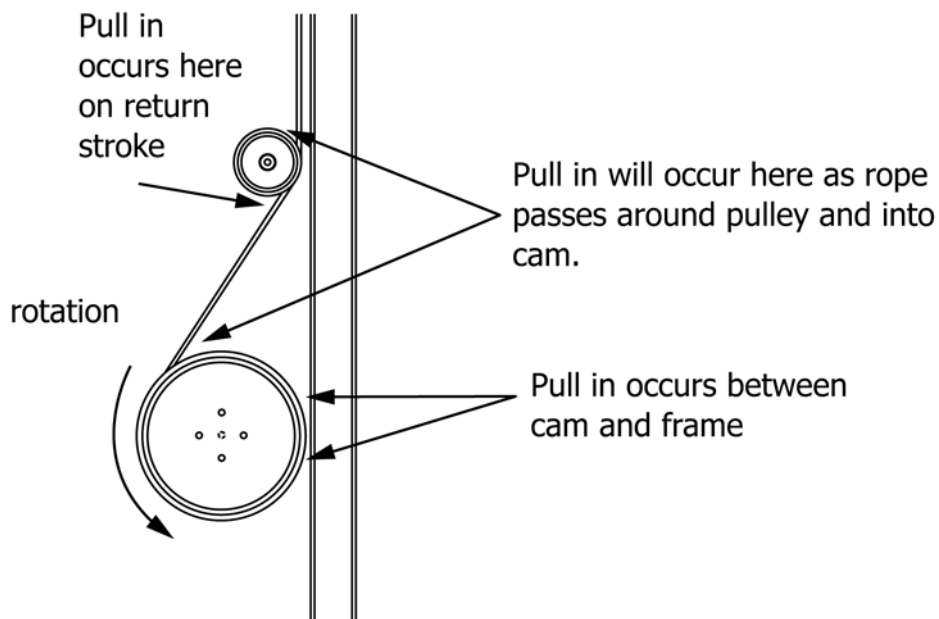

FIG. 2 Guarding of Pull-In Points—Unguarded

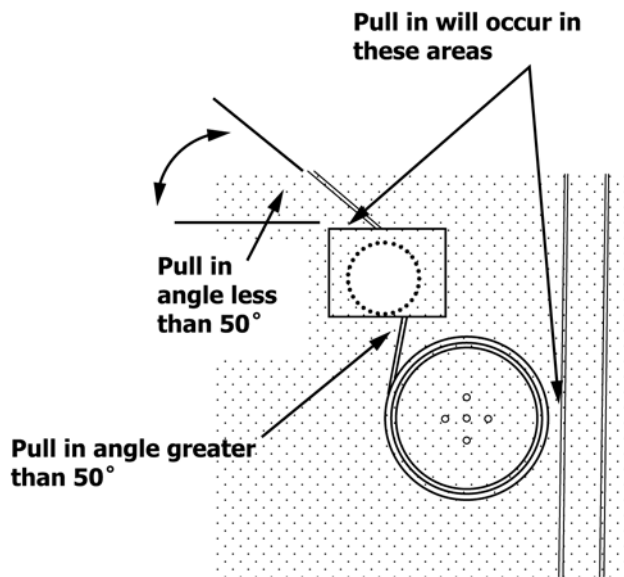

FIG. 3 Guarding of Pull-In Points—Pulley Guarding

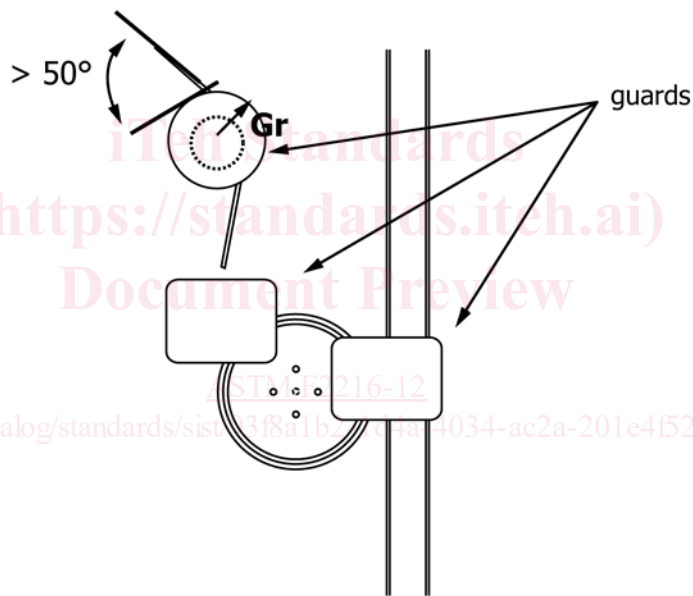

FIG. 4 Guarding of Pull-In Points—Guarded

exercise position, cannot be caught between the components. Pull-in points within the field of view of the user, during the entire range of motion of the exercise being performed, but accessible only to a third party, need not be guarded because the user can control the motion of the machine and thus prevent any inadvertent contact with a third party. A site specific label shall be present in the immediate location of the pull-in point, alerting the user or a third party to the potential for injury and to stay clear of the area. Rope or belt driven machines where the pressure between the rope/belt and the cam or pulley is less than 90 N/cm² (131 psi) are excluded from the requirements of 4.2.5.1 and 4.2.5.2.

4.3 Weight Stack Enclosures:

4.3.1 *General*—Unlike other fitness equipment, selectorized strength equipment is fully controlled by the user. Stopping the

exercise or the machine’s movement permits the user to prevent inadvertent contact with weight stacks within the field of view of the user. Weight stack enclosures may assist in preventing uncontrolled access by third parties outside this field of view. Weight stack enclosures shall be made available as an additional option by the manufacturer to the purchaser of institutional selectorized strength equipment. Weight stack enclosures shall be designed in accordance with the parameters outlined in 4.3.2 – 4.3.4. For consumer selectorized strength equipment, the manufacturer shall provide either weight stack enclosures designed to the parameters detailed in 4.3.2 – 4.3.4 or provide a lock out mechanism to secure the weight stack and prevent inadvertent use by children. Instructions and warnings shall state that this mechanism must be secured after use of the machine.