



Standard Test Method for Crack-Tip Opening Displacement (CTOD) Fracture Toughness Measurement¹

This standard is issued under the fixed designation E 1290; the number immediately following the designation indicates the year of original adoption or, in the case of revision, the year of last revision. A number in parentheses indicates the year of last reapproval. A superscript epsilon (ϵ) indicates an editorial change since the last revision or reapproval.

1. Scope

1.1 This test method covers the determination of critical crack-tip opening displacement (CTOD) values at one or more of several crack extension events. These CTOD values can be used as measures of fracture toughness for metallic materials, and are especially appropriate to materials that exhibit a change from ductile to brittle behavior with decreasing temperature. This test method applies specifically to notched specimens sharpened by fatigue cracking. The recommended specimens are three-point bend [SE(B)] compact [C(T)], or arc-shaped bend [A(B)] specimens. The loading rate is slow and influences of environment (other than temperature) are not covered. The specimens are tested under crosshead or clip gage displacement controlled loading.

1.1.1 The recommended specimen thickness, B , for the SE(B) and C(T) specimens is that of the material in thicknesses intended for an application. For the A(B) specimen, the recommended depth, W , is the wall thickness of the tube or pipe from which the specimen is obtained. Superficial surface machining may be used when desired.

1.1.2 For the recommended three-point bend specimens [SE(B)], width, W , is either equal to, or twice, the specimen thickness, B , depending upon the application of the test. (See 4.3 for applications of the recommended specimens.) For SE(B) specimens the recommended initial normalized crack size is $0.45 \leq a_o/W \leq 0.70$. The span-to-width ratio (S/W) is specified as 4.

1.1.3 For the recommended compact specimen [C(T)] the initial normalized crack size is $0.45 \leq a_o/W \leq 0.70$. The half-height-to-width ratio (H/W) equals 0.6 and the width to thickness ratio W/B is specified to be 2.

1.1.4 For the recommended arc-shaped bend [A(B)] specimen, B is one-half the specimen depth, W . The initial normalized crack size is $0.45 < a_o/W < 0.55$. The span to width ratio, S/W , may be either 3 or 4 depending on the ratio of the inner to outer tube radius. For an inner radius, r_1 , to an outer radius, r_2 , ratio of > 0.6 to 1.0, a span to width ratio, S/W , of 4 may be used. For r_1/r_2 ratios from 0.4 to 0.6, an S/W of 3 may be used.

¹ This test method is under the jurisdiction of ASTM Committee E-8 on Fatigue and Fracture and is the direct responsibility of Subcommittee E08.08 on Elastic-Plastic Fracture Mechanics Technology.

Current edition approved June 10, 1999. Published September 1999. Originally published as E 1290 – 89. Last previous edition E 1290 – 93.

1.2 This standard does not purport to address all of the safety concerns, if any, associated with its use. It is the responsibility of the user of this standard to establish appropriate safety and health practices and determine the applicability of regulatory limitations prior to use.

2. Referenced Documents

2.1 ASTM Standards:

- E 4 Practices for Force Verification of Testing Machines²
- E 8 Test Methods for Tension Testing of Metallic Materials²
- E 399 Test Method for Plane-Strain Fracture Toughness of Metallic Materials²
- E 1820 Test Method for Measurement of Fracture Toughness²
- E 1823 Terminology Relating to Fatigue and Fracture Testing²

3. Terminology

3.1 Terminology E 1823 is applicable to this test method.

3.2 Definitions:

3.2.1 *crack tip opening displacement, (CTOD), $\delta[L]$* —the crack displacement due to elastic and plastic deformation at variously defined locations near the original (prior to an application of force) crack tip.

3.2.1.1 *Discussion*—In this test method, CTOD is the displacement of the crack surfaces normal to the original (unloaded) crack plane at the tip of the fatigue precrack, a_o .

In CTOD testing, $\delta_c[L]$ is the value of CTOD at the onset of unstable brittle crack extension (see 3.2.13) or pop-in (see 3.2.7) when $\Delta a_p < 0.2$ mm (0.008 in.). The force P_c and the clip gage displacement v_c , for δ_c are indicated in Fig. 1.

In CTOD testing, $\delta_u[L]$ is the value of CTOD at the onset of unstable brittle crack extension (see 3.2.13) or pop-in (see 3.2.7) when the event is preceded by $\Delta a_p > 0.2$ mm (0.008 in.). The force P_u and the clip gage displacement v_u , for δ_u are indicated in Fig. 1.

In CTOD testing, $\delta_m[L]$ is the value of CTOD at the first attainment of a maximum force plateau for fully plastic behavior. The force P_m and the clip gage displacement v_m , for δ_m are indicated in Fig. 1.

3.2.2 *effective yield strength, $\sigma_Y [FL^{-2}]$* —an assumed value of uniaxial yield strength that represents the influence of plastic

² Annual Book of ASTM Standards, Vol 03.01.

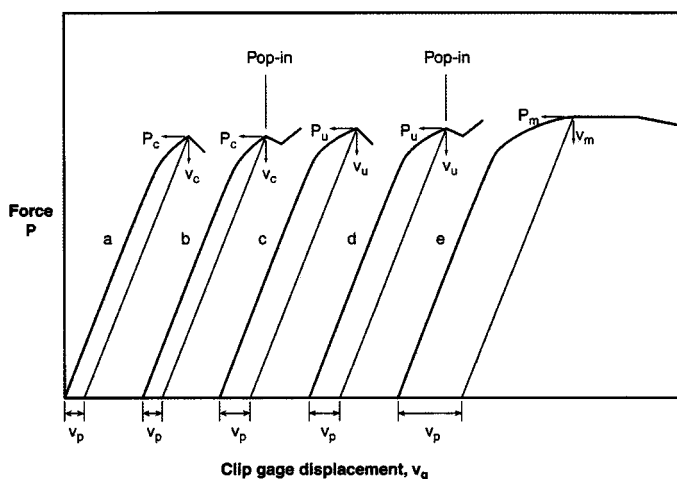

NOTE 1—Construction lines drawn parallel to the elastic loading slope to give v_p , the plastic component of total displacement, v_g .

NOTE 2—In curves b and d, the behavior after pop-in is a function of machine/specimen compliance, instrument response, etc.

FIG. 1 Types of Force Versus Clip Gage Displacement Records

yielding upon fracture test parameters.

3.2.2.1 *Discussion*—The calculation of σ_Y is the average of the 0.2 % offset yield strength (σ_{YS}), and the tensile strength (σ_{TS}), that is $(\sigma_{YS} + \sigma_{TS})/2$. Both σ_{YS} and σ_{TS} are determined in accordance with Test Methods E 8.

3.2.3 *original crack size*, a_o [L]—see Terminology E 1823.

3.2.4 *original uncracked ligament*, b_o [L]—the distance from the original crack front to the back surface of the specimen at the start of testing, $b_o = W - a_o$.

3.2.5 *physical crack extension*, Δa_p [L]—an increase in physical crack size, $\Delta a_p = a_p - a_o$.

3.2.6 *physical crack size*, a_p [L]—see Terminology E 1823.

3.2.6.1 *Discussion*—In CTOD testing, $a_p = a_o + \Delta a_p$.

3.2.7 *pop-in*—a discontinuity in the force versus clip gage displacement record. The record of a pop-in shows a sudden increase in displacement and, generally, a decrease in force. Subsequently, the displacement and force increase to above their respective values at pop-in.

3.2.8 *slow stable crack extension* [L]—a displacement controlled crack extension beyond the stretch zone width (see 3.2.12). The extension stops when the applied displacement is held constant.

3.2.9 *specimen span*, S [L]—the distance between specimen supports in a bend specimen.

3.2.10 *specimen thickness*, B [L]—see Terminology E 1823.

3.2.11 *specimen width*, W [L]—see Terminology E 1823.

3.2.12 *stretch zone width*, SZW [L]—the length of crack extension that occurs during crack-tip blunting, for example, prior to the onset of unstable brittle crack extension, pop-in, or slow stable crack extension. The SZW is in the same plane as the original (unloaded) fatigue precrack and refers to an extension beyond the original crack size.

3.2.13 *unstable brittle crack extension* [L]—an abrupt crack extension that occurs with or without prior stable crack extension in a standard test specimen under crosshead or clip gage displacement control.

4. Summary of Test Method

4.1 The objective of the test is to determine the value of

CTOD at one or more of several crack extension events. The values of CTOD may correspond to: δ_c , the onset of unstable brittle crack extension with no significant prior slow stable crack extension (see 3.2.1); δ_u , the onset of unstable brittle crack extension following prior slow stable crack extension; δ_m , at the first attainment of a maximum force plateau for fully plastic behavior.

4.2 The test method involves crosshead or clip gage displacement controlled three-point bend loading or pin loading of fatigue precracked specimens. Force versus clip gage crack opening displacement is recorded, for example, Fig. 1. The forces and displacements corresponding to the specific events in the crack initiation and extension process are used to determine the corresponding CTOD values. For values of δ_c , δ_u and δ_m , the corresponding force and clip gage displacements are obtained directly from the test records.

4.3 The rectangular section bend specimen and the compact specimen are intended to maximize constraint and these are generally recommended for those through-thickness crack types and orientations for which such geometries are feasible. For the evaluation of surface cracks in structural applications for example, orientations T-S or L-S (Terminology E 1823), the square section bend specimen is recommended. Also for certain situations in curved geometry source material or welded joints, the square section bend specimen may be preferred. Square section bend specimens may be necessary in order to sample an acceptable volume of a discrete microstructure.

4.4 The arc-shaped bend specimen permits toughness testing in the C-R orientation (Terminology E 1823), for pipe or tube. This orientation is of interest since pipes and tubes under pressure often fail with longitudinal cracks. The specimen geometry is convenient for obtaining samples with minimal use of material.

5. Significance and Use

5.1 This test method characterizes the fracture toughness of materials through the determination of crack-tip opening displacement (CTOD) at one of three events: (a) onset of unstable

ASTM E 1290

crack extension without significant prior stable crack extension, (b) onset of unstable crack extension with significant prior stable crack extension, or (c) achievement of plastic limit load with or without significant stable crack extension. This test method may also be used to characterize the toughness of materials for which the properties and thickness of interest preclude the determination of K_{Ic} fracture toughness in accordance with Test Method E 399.

5.2 The different values of CTOD determined by this test method characterize the resistance of a material to crack initiation and early crack extension at a given temperature.

5.3 The values of CTOD may be affected by specimen dimensions. It has been shown that values of CTOD determined on SE(B) specimens using the square section geometry may not be the same as those using the rectangular section geometry, and may differ from those obtained with either the (C)T or (A)B specimens.

5.4 The values of CTOD determined by this test method may serve the following purposes:

5.4.1 In research and development, CTOD testing can show the effects of certain parameters on the fracture toughness of metallic materials significant to service performance. These parameters include material composition, thermo-mechanical processing, welding, and thermal stress relief.

5.4.2 For specifications of acceptance and manufacturing quality control of base materials, weld metals, and weld heat affected zones.

5.4.3 For inspection and flaw assessment criteria, when used in conjunction with fracture mechanics analyses. Awareness of differences that may exist between laboratory test and field conditions is required to make proper flaw assessment (see 4.3 and 4.4).

6. Apparatus

6.1 This procedure involves measurement of applied force, P , and clip gage crack opening displacement, v . Force versus

displacement is autographically recorded on an x - y plotter for visual display, or converted to digital form for accumulation in a computer information storage facility and subsequent processing. Testing is performed under crosshead or clip gage displacement control in a compression or tension testing machine, or both, that conforms to the requirements of Practices E 4.

6.2 *Fixturing for Three-Point Bend Specimens*—A recommended SE(B) or A(B) specimen fixture is shown in Fig. 2. Friction effects between the support rollers and specimen are reduced by allowing the rollers to rotate during the test. The use of high hardness steel of the order of 40 HRC or more is recommended for the fixture and rollers to prevent indentation of the platen surfaces.

6.3 *Tension Testing Clevis*—A loading clevis suitable for testing C(T) specimens is shown in Fig. 3. Each leg of the specimen is held by such a clevis and loaded through pins, in order to allow rotation of the specimen during testing. To provide rolling contact between the loading pins and the clevis holes, these holes are produced with small flats on the loading surfaces. Other clevis designs may be used if it can be demonstrated that they will accomplish the same result as the design shown. Clevises and pins should be fabricated from steels of sufficient strength and hardness (greater than 40 HRC) to elastically resist indentation forces. The critical tolerances and suggested proportions of the clevis and pins are given in Fig. 3. These proportions are based on specimens having $W/B = 2$ for $B > 12.7$ mm (0.5 in.) and $W/B = 4$ for $B \leq 12.7$ mm (0.5 in.). If a 1930-MPa (280 000-psi) yield strength maraging steel is used for the clevis and pins, adequate strength will be obtained. If lower strength grip material is used, or if substantially larger specimens are required at a given σ_{ys}/E ratio, then heavier grips will be required. As indicated in Fig. 3, the clevis corners may be cut off sufficiently to accommodate seating of the clip gage in specimens less than 9.5 mm (0.375 in.) thick.

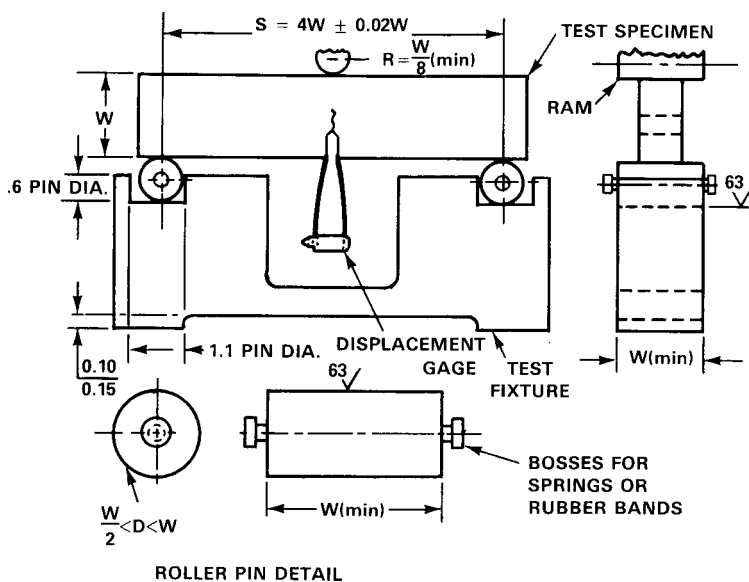

NOTE 1—Roller pins and specimen contact surface of loading ram must be parallel to each other within 0.002W.

NOTE 2—0.10 in. = 2.54 mm; 0.15 in. = 3.81 mm.

FIG. 2 SE(B) Test Fixture Design

E 1290

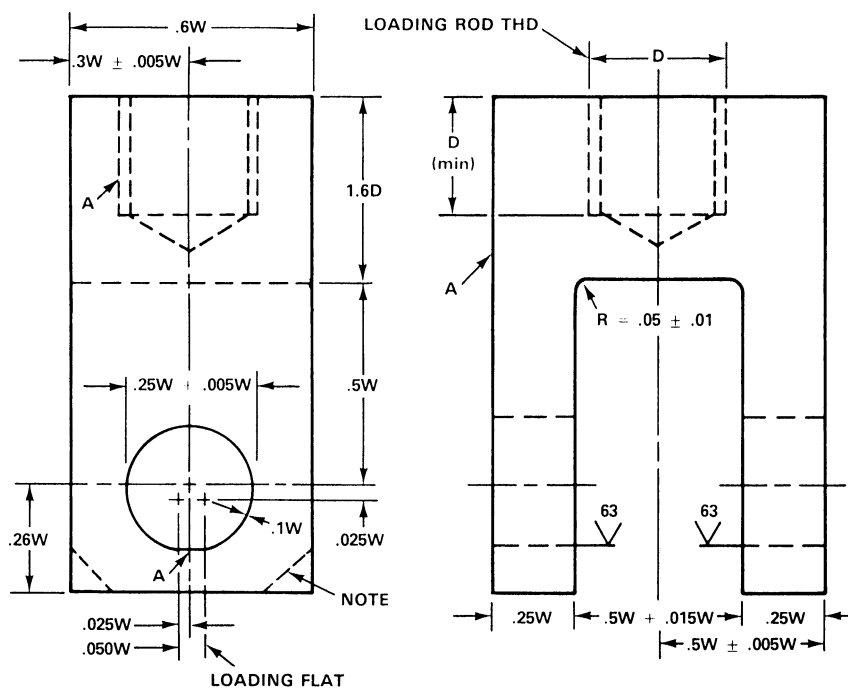

A — SURFACES MUST BE FLAT, IN-LINE & PERPENDICULAR, AS APPLICABLE TO WITHIN 0.002 IN T.I.R. (.05 mm)

NOTE 1—Corners of the clevis may be removed as necessary to accommodate the clip gage.

FIG. 3 Clevis for C(T) Specimen Testing

Attention should be given to achieving good alignment through careful machining of all auxiliary gripping fixtures.

6.4 Displacement Measuring Devices:

6.4.1 Displacement measuring gages are used to measure opening displacements on SE(B) specimens at either knife edges a distance z beyond the crack mouth, Fig. 4a, or at the crack mouth ($z = 0$) in the case of integral knife edges, Fig. 4b. For C(T) specimens, where the opening displacement is not measured on the load line, the difference between the load line and the displacement measuring point shall constitute the dimension z (see 9.2). Alternatively, when the opening displacements on C(T) specimens are made on or within $\pm 0.002 W$ of the load line, it may be assumed that $z = 0$. For A(B) specimens, special measurements must be taken to establish location of the clip gage knife edges with respect to the crack plane. Paragraphs 8.9.4 and 8.9.5 provide more detail on required measurements.

6.4.2 The clip gage recommended in Test Method E 399 may be used in cases where the total expected displacement is 2.5 mm (0.1 in.) or less. Sensitivity and linearity requirements specified in Test Method E 399, shall be met over the full working range of the gage. In addition, the gage is to be calibrated to within $\pm 1\%$ of the working range.

6.4.3 For cases where a linear working range of up to 8 mm (0.3 in.) or more is needed, an enlarged gage such as that shown in Fig. 5 can be used. Both linearity and accuracy of the equipment or system used shall be demonstrated to be within $\pm 1\%$ of the working range of the equipment.

6.4.4 The seating between the clip gage and knife edges shall be firm and free from friction drag.

6.5 *Force Measurement*—The sensitivity of the force sensing device shall be sufficient to avoid distortion caused by over amplification and the device shall have a linearity identical to that for the displacement signal. The combination of force sensing device and recording system shall permit the force P to be determined from the test record within an accuracy of $\pm 1\%$.

7. Specimen Configurations, Dimensions, and Preparation

7.1 The SE(B) specimens, shown in Fig. 6 and Fig. 7, are tested with a span to width ratio, S/W , of 4. Therefore, it is suggested that overall specimen length should be at least $4.5 W$.

7.1.1 The standard bend specimens shall be of thickness, B , at least equal to that employed in the specific structural application of interest, or the original product form thickness. The specimen should be one of the types shown in Fig. 6 and Fig. 7.

7.1.2 The recommended original crack size, a_o , of the SE(B) specimen shall be within the range $0.45 W \leq a_o \leq 0.70 W$.

7.1.3 In order to machine fatigue crack-starter notches to depths greater than 2.5 mm (0.1 in.), a stepped width notch is an allowed exception. This is acceptable, provided that: (a) the stepped width notch falls completely within the envelope shown in Fig. 8, and, (b) the length of the fatigue precrack extension from the machined notch tip satisfies the requirement of 7.4.2. Separate or integral knife edges for accommodating clip gages are shown in Fig. 4.

7.2 The recommended C(T) specimen designs are shown in Fig. 9. These are similar to the configurations recommended in

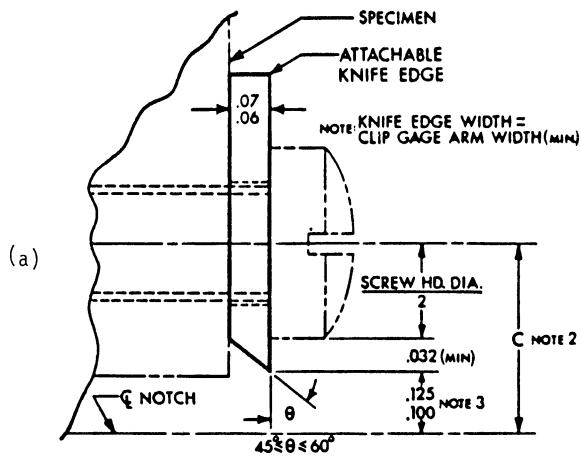

NOTE 1—Dimensions are in inches.

NOTE 2—Effective gage length = $2C + \text{Screw Thread Diameter} \leq W/2$. (This will always be greater than the gage length specified in Test Method E 399, A 1.1.)

NOTE 3—Dimension shown corresponds to clip gage spacer block dimension in Test Method E 399, Annex A1 .

		Metric Equivalents				
in.	0.032	0.06	0.07	0.100	0.125	
mm	0.81	1.5	1.8	2.54	3.18	

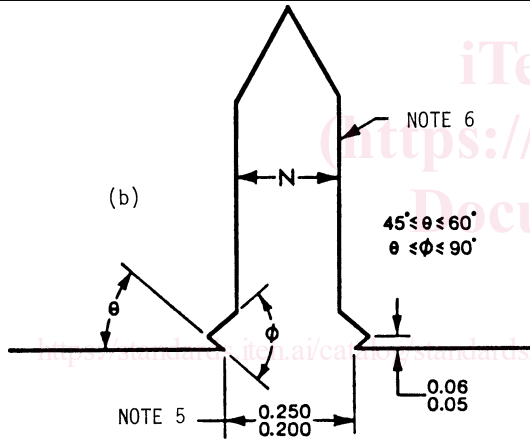

NOTE 4—Dimensions in inches.

NOTE 5—Gage length shown corresponds to clip gage spacer block dimensions shown in Test Method E 399, Annex A1 , but other gage lengths may be used provided they are appropriate to the specimen.

NOTE 6—For starter notch configurations see Fig. 8

		Metric Equivalents			
in.	0.050	0.060	0.200	0.250	
mm	1.3	1.5	5.1	6.4	

FIG. 4 Knife Edges for Location of Clip Gages

Test Method E 1820. The designs are suitable for use with flat bottom clevises of Test Method E 399 design (see Fig. 3). A cut-out section on the front face provides room to attach razor blade edges on the load line of the specimen. The sharp edges of the blades shall be square with respect to specimen surfaces and parallel within 0.5° . A specially prepared spacer block can be used to achieve these requirements.

7.2.1 The C(T) specimen shall be of thickness, B , at least equal to that employed in the specific structural application of interest, or the original product form thickness.

7.2.2 The C(T) specimen half-height to width ratio H/W is

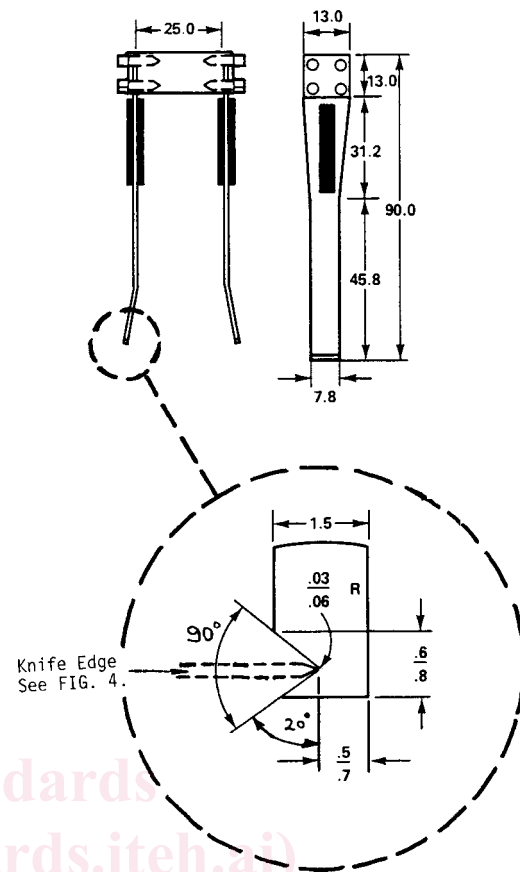

Knife Edge See FIG. 4.

NOTE 1—All dimensions in mm.

FIG. 5 Clip Gage Design for 8-mm (0.3-in.) and More Working Range (see 6.4.3.)

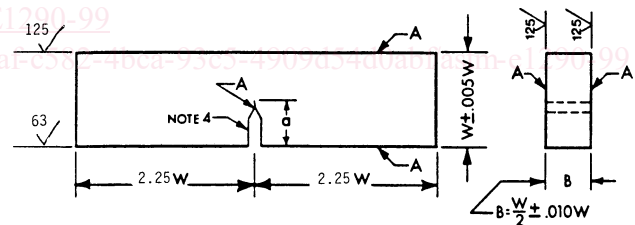

NOTE 1—A surfaces shall be perpendicular and parallel as applicable within $0.001 W$ TIR.

NOTE 2—Crack starter notch shall be perpendicular to specimen surfaces to within $\pm 2^\circ$.

NOTE 3—Integral or attachable knife edges for clip gage attachment may be used (see Fig. 4).

NOTE 4—For starter notch and fatigue crack configurations see Fig. 8. **FIG. 6 Proportional Dimensions and Tolerances for Rectangular Section SE(B) Specimens**

0.6, and the width W to thickness B ratio W/B is specified to be 2.

7.2.3 The original crack length, a_o , of the compact specimen shall be within the range $0.45 W \leq a_o \leq 0.70 W$.

7.3 The arc-shaped bend specimen (1)³ is a single-edge notched and fatigue cracked ring segment loaded in bending.

³ The boldface numbers in parentheses refer to the list of references at the end of this test method.

