

FINAL
DRAFT

INTERNATIONAL
STANDARD

ISO/FDIS
8529-1

ISO/TC 85/SC 2

Secretariat: AFNOR

Voting begins on:
2021-08-20

Voting terminates on:
2021-10-15

Reference neutron radiations fields — Part 1: Characteristics and methods of production

Champs de rayonnement neutronique de référence —

Partie 1: Caractéristiques et méthodes de production

iTeh STANDARD PREVIEW
(standards.iteh.ai)

ISO/FDIS 8529-1

<https://standards.iteh.ai/catalog/standards/sist/5cbcf9b-c53d-4acb-97b5-3c30b45a1a69/iso-fdis-8529-1>

RECIPIENTS OF THIS DRAFT ARE INVITED TO SUBMIT, WITH THEIR COMMENTS, NOTIFICATION OF ANY RELEVANT PATENT RIGHTS OF WHICH THEY ARE AWARE AND TO PROVIDE SUPPORTING DOCUMENTATION.

IN ADDITION TO THEIR EVALUATION AS BEING ACCEPTABLE FOR INDUSTRIAL, TECHNOLOGICAL, COMMERCIAL AND USER PURPOSES, DRAFT INTERNATIONAL STANDARDS MAY ON OCCASION HAVE TO BE CONSIDERED IN THE LIGHT OF THEIR POTENTIAL TO BECOME STANDARDS TO WHICH REFERENCE MAY BE MADE IN NATIONAL REGULATIONS.



Reference number
ISO/FDIS 8529-1:2021(E)

© ISO 2021

iTeh STANDARD PREVIEW
(standards.iteh.ai)

ISO/FDIS 8529-1

<https://standards.iteh.ai/catalog/standards/sist/5cbcf9b-c53d-4acb-97b5-3c30b45a1a69/iso-fdis-8529-1>



COPYRIGHT PROTECTED DOCUMENT

© ISO 2021

All rights reserved. Unless otherwise specified, or required in the context of its implementation, no part of this publication may be reproduced or utilized otherwise in any form or by any means, electronic or mechanical, including photocopying, or posting on the internet or an intranet, without prior written permission. Permission can be requested from either ISO at the address below or ISO's member body in the country of the requester.

ISO copyright office
CP 401 • Ch. de Blandonnet 8
CH-1214 Vernier, Geneva
Phone: +41 22 749 01 11
Email: copyright@iso.org
Website: www.iso.org

Published in Switzerland

Contents

Page

Foreword	iv
Introduction	v
1 Scope	1
2 Normative references	1
3 Terms and definitions	1
4 Broad spectrum reference neutron radiation fields produced with radionuclide sources ... 3	3
4.1 Overview.....	3
4.2 Types of calibration sources.....	3
4.3 Source shape and encapsulation.....	4
4.4 Photon component of the neutron field.....	4
4.5 Energy distribution of neutron source emission rate.....	5
4.6 Neutron fluence rate produced by a neutron source.....	5
4.7 Determination of the neutron source emission rate.....	6
4.8 Irradiation facility.....	6
5 Reference neutron radiation fields for the determination of the response of neutron-measuring devices as a function of neutron energy 7	7
5.1 Overview.....	7
5.2 General properties.....	7
5.3 Reference neutron radiation fields produced with particle accelerators..... 8	8
5.3.1 General requirements.....	8
5.3.2 Energy of charged particles.....	8
5.3.3 Neutron spectrum.....	9
5.3.4 Parasitic and scattered neutron background.....	9
5.3.5 Neutron fluence measurement and monitoring.....	10
5.4 Reference neutron radiation fields produced with reactors..... 10	10
5.4.1 General requirements.....	10
5.4.2 Production and monitoring.....	10
6 Reference thermal neutron radiation fields 10	10
Annex A (informative) Tabular and graphical representation of the neutron spectra for radionuclide sources 12	12
Annex B (normative) Energy distribution of the neutron emission rate for the ²⁵²Cf source 14	14
Annex C (informative) Characteristics of D₂O-moderated ²⁵²Cf sources 16	16
Annex D (informative) Characteristics of ²⁴¹Am-Be sources 20	20
Annex E (informative) Angular source emission rate characteristics of radionuclide neutron sources 24	24
Annex F (normative) Conventional thermal-neutron fluence rate 27	27
Bibliography 28	28

Foreword

ISO (the International Organization for Standardization) is a worldwide federation of national standards bodies (ISO member bodies). The work of preparing International Standards is normally carried out through ISO technical committees. Each member body interested in a subject for which a technical committee has been established has the right to be represented on that committee. International organizations, governmental and non-governmental, in liaison with ISO, also take part in the work. ISO collaborates closely with the International Electrotechnical Commission (IEC) on all matters of electrotechnical standardization.

The procedures used to develop this document and those intended for its further maintenance are described in the ISO/IEC Directives, Part 1. In particular the different approval criteria needed for the different types of ISO documents should be noted. This document was drafted in accordance with the editorial rules of the ISO/IEC Directives, Part 2 (see www.iso.org/directives).

Attention is drawn to the possibility that some of the elements of this document may be the subject of patent rights. ISO shall not be held responsible for identifying any or all such patent rights. Details of any patent rights identified during the development of the document will be in the Introduction and/or on the ISO list of patent declarations received (see www.iso.org/patents).

Any trade name used in this document is information given for the convenience of users and does not constitute an endorsement.

For an explanation on the voluntary nature of standards, the meaning of ISO specific terms and expressions related to conformity assessment, as well as information about ISO's adherence to the World Trade Organization (WTO) principles in the Technical Barriers to Trade (TBT) see the following URL: www.iso.org/iso/foreword.html. (standards.iteh.ai)

This document was prepared by Technical Committee ISO/TC 85, *Nuclear energy, nuclear technologies, and radiological protection*, Subcommittee SC 2, *Radiation protection*.

A list of all the parts in the ISO 8529 series can be found on the ISO website.

Any feedback or questions on this document should be directed to the user's national standards body. A complete listing of these bodies can be found at www.iso.org/members.html.

Introduction

This is the first of a set of three International Standards concerning the calibration of dosimeters and dose rate meters for neutron radiation for protection purposes. It describes the characteristics and methods of production of the reference neutron radiation fields to be used for calibrations. ISO 8529-2 describes fundamentals related to the physical quantities characterizing the radiation field and calibration procedures in general terms, with emphasis on active dose rate meters and the use of radionuclide sources. ISO 8529-3 deals with dosimeters for area and individual monitoring, describing the respective procedures for calibrating and determining the response in terms of the International Commission on Radiation Units and Measurements (ICRU) operational quantities. Conversion coefficients for converting neutron fluence into these operational quantities are provided in ISO 8529-3.

iTeh STANDARD PREVIEW (standards.iteh.ai)

[ISO/FDIS 8529-1](https://standards.iteh.ai/catalog/standards/sist/5cbcf9b-c53d-4acb-97b5-3c30b45a1a69/iso-fdis-8529-1)

<https://standards.iteh.ai/catalog/standards/sist/5cbcf9b-c53d-4acb-97b5-3c30b45a1a69/iso-fdis-8529-1>

iTeh STANDARD PREVIEW
(standards.iteh.ai)

ISO/FDIS 8529-1

<https://standards.iteh.ai/catalog/standards/sist/5cbcf9b-c53d-4acb-97b5-3c30b45a1a69/iso-fdis-8529-1>

Reference neutron radiations fields —

Part 1: Characteristics and methods of production

1 Scope

This document specifies the reference neutron fields, in the energy range from thermal up to 20 MeV, for calibrating neutron-measuring devices used for radiation protection purposes and for determining their response as a function of neutron energy.

This document is concerned only with the methods of producing and characterizing the reference neutron radiation fields. The procedures for applying these radiation fields for calibrations are described in References [1] and [2].

The reference neutron radiation fields specified are the following:

- neutron fields from radionuclide sources, including neutron fields from sources in a moderator;
- neutron fields produced by nuclear reactions with charged particles from accelerators;
- neutron fields from reactors.

In view of the methods of production and use of them, these reference neutron radiation fields are divided, for the purposes of this document, into the following three separate clauses:

- In [Clause 4](#), radionuclide neutron sources with wide spectra are specified for the calibration of neutron-measuring devices. These sources should be used by laboratories engaged in the routine calibration of neutron-measuring devices, the particular design of which has already been type tested.
- In [Clause 5](#), accelerator-produced monoenergetic neutrons and reactor-produced neutrons with wide or quasi monoenergetic spectra are specified for determining the response of neutron-measuring devices as a function of neutron energy. Since these reference neutron radiation fields are produced at specialized and well-equipped laboratories, only the minimum of experimental detail is given.
- In [Clause 6](#), thermal neutron fields are specified. These fields can be produced by moderated radionuclide sources, accelerators, or reactors.

2 Normative references

The following documents are referred to in the text in such a way that some or all of their content constitutes requirements of this document. For dated references, only the edition cited applies. For undated references, the latest edition of the referenced document (including any amendments) applies.

ISO 29661, *Reference radiation fields for radiation protection — Definitions and fundamental concepts*

3 Terms and definitions

For the purposes of this document, the terms and definitions of ISO 29661 and the following apply:

ISO and IEC maintain terminological databases for use in standardization at the following addresses:

- ISO Online browsing platform: available at <https://www.iso.org/obp>

— IEC Electropedia: available at <https://www.electropedia.org/>

3.1 neutron emission rate of a neutron source

B
differential quotient of N with respect to time, where N is the number of neutrons being emitted from the source, in all directions

$$B = \frac{dN}{dt}$$

Note 1 to entry: The unit of the neutron emission rate is s^{-1} .

**3.2 direction distribution of the neutron emission rate
angular distribution of the neutron emission rate**

B_{Ω}
differential quotient of B with respect to solid angle, where Ω is a specific spatial direction

$$B_{\Omega} = \frac{dB}{d\Omega}$$

Note 1 to entry: The unit of the direction distribution of the neutron emission rate is $s^{-1} sr^{-1}$.

**3.3 energy distribution of the neutron emission rate
spectral neutron emission rate**

B_E
differential quotient of B with respect to energy, where E is the neutron energy

$$B_E = \frac{dB}{dE}$$

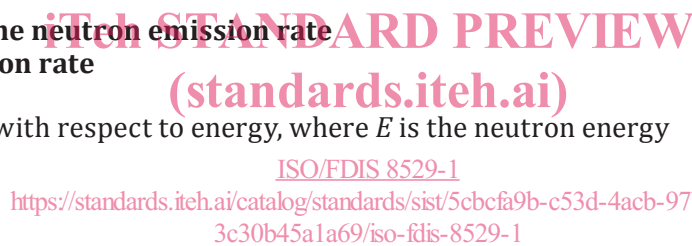

Note 1 to entry: The unit of the neutron spectral emission rate is $s^{-1} J^{-1}$; a frequently used unit is $s^{-1} MeV^{-1}$.

Note 2 to entry: The terms “spectrum” and “energy distribution” are considered to be equivalent.

Note 3 to entry: The neutron source emission rate B is derived from B_E as follows:

$$B = \int_0^{\infty} B_E dE$$

Note 4 to entry: At a distance l from a point source, the energy distribution of the fluence rate φ_E , due to neutrons emitted isotropically from the point source with a spectral neutron emission rate B_E (neglecting the influence of the air and the surrounding material), is given by:

$$\varphi_E = \frac{B_E}{4\pi l^2}$$

3.4 fluence-averaged neutron energy \bar{E}
neutron energy averaged over the energy distribution of the fluence

$$\bar{E} = \frac{1}{\Phi} \int_0^{\infty} E \cdot \Phi_E(E) dE$$

where $\Phi_E(E)$ is the energy distribution of the neutron fluence.

4 Broad spectrum reference neutron radiation fields produced with radionuclide sources

4.1 Overview

In this clause, reference neutron radiation fields produced by radionuclide neutron sources are specified, which are particularly suited for the calibration of neutron-measuring devices (see Reference [2]).

Thermal neutron reference fields are achievable by moderating radionuclide sources, but are covered by [Clause 6](#).

4.2 Types of calibration sources

The neutron sources given in [Table 1](#) shall be used to produce reference neutron radiation fields. The numerical values given in [Table 1](#) are to be taken only as a guide to the prominent features of the sources, since the properties of a specific source vary with the construction of the source, because of scattering and absorption of neutron and gamma radiation, and with the isotopic impurities of the radioactive material used. Hence details of the source encapsulation are specified (see [4.3](#)), and the method for determining the anisotropy of the neutron emission is specified (see [Annex E](#)).

^{252}Cf has a high specific neutron emission rate and ^{252}Cf sources are therefore comparatively small. Because of their short half-life of 2,647 years, they need regular replacement.

The D_2O -moderated ^{252}Cf source is ideally composed of a point ^{252}Cf source located in the centre of a 300 mm diameter heavy-water sphere, surrounded by

- a) an iron shell, and
- b) a cadmium shell with thicknesses 0,8 mm and 1 mm, respectively.

In practice, a number of designs have been developed in reference laboratories, being slightly different in terms of construction details, such as the guide used to locate the source in the sphere centre, the material used to contain the heavy water, and the structure used to suspend or hold the moderating sphere. In addition, every moderating assembly has specific D_2O purity and ^{252}Cf source capsule. The experience of reference laboratories suggests that variability in the construction of D_2O -moderated ^{252}Cf sources results in non-negligible differences in the energy distribution of the neutron fluence^[3]. Laboratories should characterize their D_2O -moderated ^{252}Cf sources by simulations and spectral measurements. The energy distribution of the neutron emission rate and spectrum-averaged quantities of these fields should be checked through comparisons. A representative spectrum of the D_2O -moderated ^{252}Cf source was derived, for the purposes of this document, by Monte Carlo simulations. In this model, 11,4 % of the source neutrons are absorbed in the moderating assembly. See [Annex C](#) for details.

^{241}Am -Be (α, n) neutron sources include appropriate alloys, mixtures or compounds of americium, such as a compressed mixture of americium oxide and beryllium as appropriate. See [Annex D](#) for details.

In addition to the sources listed in [Table 1](#), sources such as ^{241}Am -B(α, n)^{[4]-[6]}, Pu-Li(α, n)^{[7],[8]}, Pu-Be(α, n)^[8], ^{241}Am -F(α, n)^[6], ^{241}Am -Li(α, n)^[9] and ^{244}Cm ^[10] are also used but are not addressed specifically in this document¹⁾.

1) Plutonium-based (α, n) sources may actually include more than one plutonium isotope, such as ^{237}Pu , ^{238}Pu , ^{239}Pu , ^{240}Pu , ^{241}Pu and ^{242}Pu .

Table 1 — Reference radionuclide neutron sources for calibrating neutron-measuring devices

Source	Half-life a^d	Fluence-averaged energy ^a MeV	Specific source emission rate ^b $s^{-1} kg^{-1}$	Ratio of photon to neutron ambient-dose-equivalent rates ^c
²⁵² Cf (D ₂ O moder- ated)	2,647	0,57	$2,1 \times 10^{15}$	<0,18 ^e
²⁵² Cf	2,647	2,13	$2,4 \times 10^{15}$	0,05 ^f
			$s^{-1} Bq^{-1}$	
²⁴¹ Am-Be(α,n) small source ^g large source	432,6	4,17 4,05	6×10^{-5}	<0,035 ^h

^a The reported values are calculated applying the definition of the fluence-averaged neutron energy given in 3.4 to the spectra tabulated in Annexes B, C and D.

^b For ²⁵²Cf sources, the specific emission rate is related to the mass of californium. For the ²⁴¹Am-Be sources, this is related to the ²⁴¹Am activity and is subject to variations according to manufacturing process and degree of mixing. For both ²⁵²Cf and ²⁴¹Am-Be, these are indicative values only. For any source used to produce reference neutron fields, a determination of the neutron emission rate is needed. Information on the sources is given in references [3][11][12] for moderated ²⁵²Cf, Reference [13] for ²⁵²Cf, and references [4][5][14][16] for ²⁴¹Am-Be.

^c Calculated on the basis of the neutron spectra given in Annexes B, C and D and the conversion coefficients given in reference [17].

^d 1 a = 1 mean solar year = 31 556 926 s or 365,242 20 days. Uncertainties on ²⁵²Cf and ²⁴¹Am half-life can be assumed as 0,1 % ($k=1$) and 0,14 % ($k=1$) respectively. Half-life and related uncertainty are taken from Reference [18].

^e Data from References [12][19].

^f For approximately 2,5 mm thick steel encapsulation. The low energy gamma spectrum of ²⁵²Cf is easily shielded by the small amount of steel in the encapsulation. Other construction details are likely to affect the ratio. Data for the photon component of the ²⁵²Cf field are available in references [20][22].

^g For definition of "small" and "large" ²⁴¹Am-Be source, see Annex D.

^h For sources enclosed within an additional 1 mm to 2 mm thick lead shield, see 4.4 for more information.

4.3 Source shape and encapsulation

The shape of the source would ideally be spherical, but most practical sources are cylindrical. In the latter case, it is preferable that the diameter and length are approximately the same. The thickness of the encapsulation should be uniform and small compared to the external diameter. For a ²⁴¹Am-Be(α,n) source, the spectral distribution, mainly in the energy range below approximately 2 MeV, depends, to some extent, on the size and the composition of the source[5][15][16]. See Annex D for more details.

Sources should comply with ISO 2919 encapsulation requirements[23].

4.4 Photon component of the neutron field

For ²⁵²Cf, the ratio of photon to neutron ambient dose equivalent rate is dependent upon the age of the source because of the build-up of gamma-emitting fission products, as well as upon source encapsulation. The 5 % value reported in Table 1 refers to new sources. During the first 30 years, this is likely to remain below 10 %[20][22].

The ²⁴¹Am-Be(α,n) source may be wrapped in a lead shield to reduce the gamma component. A thickness of 1 mm to 2 mm reduces the photon to neutron dose-equivalent rate to less than 3,5 %[20][21][23]. This ratio does not depend on the Am activity and source encapsulation. The lead shield produces a negligible change (less than 1 %) in the neutron dose equivalent rate. In the absence of the lead shield, the photon to neutron dose equivalent rate (mainly from 59,5 keV gamma radiation) depends upon the source construction. Based on bibliography data[20], it decreases as the physical size of the source increases. Typical values for bare sources are 50 % for small sources (in the order of 37 GBq), 30 % and 20 % for larger sources (370 GBq and 555 GBq respectively).

4.5 Energy distribution of neutron source emission rate

The tabular and graphical representation of neutron spectra in this document is addressed in [Annex A](#).

The energy distribution reported in [Annex B](#) shall be used for ^{252}Cf sources.

The spectrum of the D_2O -moderated ^{252}Cf source is affected by the construction details of the moderating sphere, D_2O purity, and any additional material surrounding the source. See [Annex C](#) for details.

For ^{241}Am -Be, sources with different capsules, americium activity, chemical composition, granularity of the active material, and construction methods, result in slightly different spectra. This is discussed in [Annex D](#).

The fluence-averaged fluence to dose equivalent conversion coefficients, h_ϕ can be derived from the spectra using [Formula \(1\)](#):

$$h_\phi = \frac{1}{\Phi} \int_0^{\infty} h_\phi(E) \Phi_E dE \quad (1)$$

where Φ_E is taken to be proportional to B_E and $h_\phi(E)$ is the energy-dependent fluence to dose equivalent conversion coefficient from Reference [17].

4.6 Neutron fluence rate produced by a neutron source

The fluence rate produced by a neutron source is determined primarily from the neutron emission rate of the neutron source, B , and the distance between the source centre and the point of test. Neutron sources generally show anisotropic neutron emission in a coordinate system fixed in the geometrical centre of the source. The coordinate system is shown in [Figure 1](#).

The neutron emission rate, B , and its direction distribution, $\text{dB}/\text{d}\Omega$, in the direction used for calibrations, shall be determined (see also [Annex E](#)).

For the purposes of determining the direction distribution^[24], the measuring device should have the smallest solid angle consistent with deriving good statistics and should have sufficiently small energy dependence of the fluence response to avoid sensitivity to changes of the energy with the angle. Anisotropy measurements should be corrected for the contribution of scattered neutrons.

Once this is done, the neutron fluence rate, at a distance, l , from the centre of the source in a direction for which $\theta = 90^\circ$, may then be taken as per [Formula \(2\)](#):

$$\varphi_{(1,90^\circ)} = \frac{\text{dB}}{\text{d}\Omega} \times \frac{1}{l^2} \quad (2)$$

The neutron fluence rate obtained from this expression still has to be corrected for air attenuation, and scattering from air and the surrounding material. These corrections, which are only negligible in exceptional circumstances, are described in detail in Reference [1].

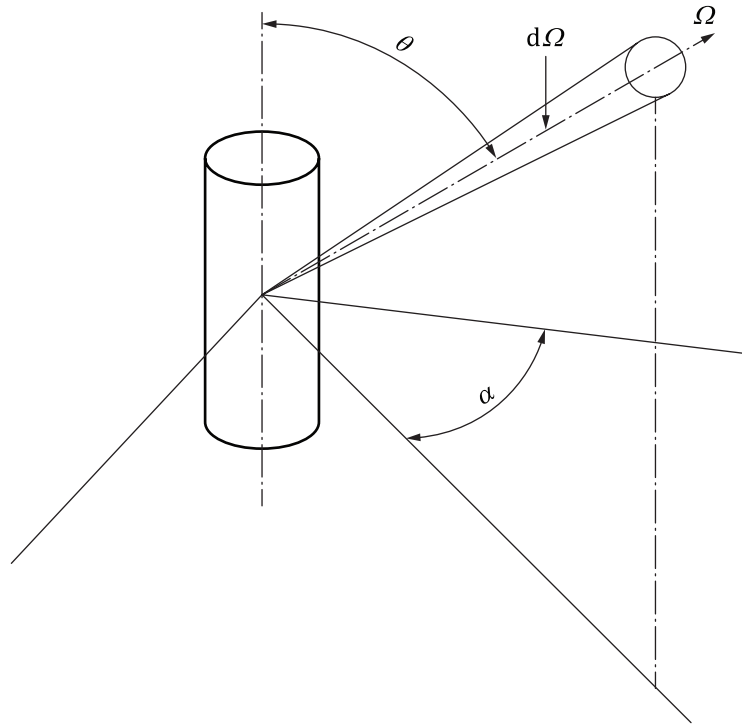

Figure 1 — Coordinate system for the case of an anisotropically emitting source

4.7 Determination of the neutron source emission rate

The emission rate from $^{241}\text{Am}\text{-Be}(\alpha, n)$ and ^{252}Cf sources shall be measured by a reference laboratory before use. Reference laboratories can generally measure the emission rate of neutron sources to within a relative standard uncertainty of about 1,5 % ($k=1$) [25].

For americium-beryllium sources there is the possibility that, with time, the constituent components may shift with respect to each other, with a resultant change in the neutron source emission rate.

The source emission rate of a ^{252}Cf source shall be corrected for radioactive decay on a day-to-day basis. It is important to take into account the decay of all the constituents of the source including the ^{250}Cf , ^{254}Cf , and ^{248}Cm in available ^{252}Cf sources [26]. Therefore, the manufacturer shall supply a certificate of the isotopic composition.

It is recommended that the emission rate of neutron sources be checked every five years. An alternative to recalibrating the sources in the manganese sulphate bath is to perform regular stability tests against stable instruments or against other sources.

For ^{252}Cf sources expected to have more than 5 % neutron emission due to the combination of ^{250}Cf and ^{248}Cm , these tests should take place more frequently.

4.8 Irradiation facility

In general, irradiation rooms have thick walls (for example concrete) for shielding. In this case, the inside dimensions should be as large as practically possible. The magnitude of the correction for room- and air-scattered neutrons, and the resulting uncertainty in the field quantities, depend critically on the size of the room. In all cases, the effects of scattered neutrons may be characterized through measurements with a shadow cone and investigations of deviations from the $1/l^2$ -relationship (where l is the distance between the neutron source and the reference point detector). Details of the recommended calibration procedures are dealt with in Reference [1].