



FINAL DRAFT International Standard

ISO/FDIS 4766

Fasteners — Slotted set screws with flat point

Fixations — Vis sans tête fendues à bout plat

ISO/TC 2/SC 11

Secretariat: **DIN**

Voting begins on:
2024-03-21

Voting terminates on:
2024-05-16

iTeh Standards
(<https://standards.iteh.ai>)
Document Preview

[ISO/FDIS 4766](https://standards.iteh.ai/catalog/standards/iso/fa581490-b199-4068-8ae3-e770766ce6cf/iso-fdis-4766)

<https://standards.iteh.ai/catalog/standards/iso/fa581490-b199-4068-8ae3-e770766ce6cf/iso-fdis-4766>

ISO/CEN PARALLEL PROCESSING

RECIPIENTS OF THIS DRAFT ARE INVITED TO SUBMIT, WITH THEIR COMMENTS, NOTIFICATION OF ANY RELEVANT PATENT RIGHTS OF WHICH THEY ARE AWARE AND TO PROVIDE SUPPORTING DOCUMENTATION.

IN ADDITION TO THEIR EVALUATION AS BEING ACCEPTABLE FOR INDUSTRIAL, TECHNOLOGICAL, COMMERCIAL AND USER PURPOSES, DRAFT INTERNATIONAL STANDARDS MAY ON OCCASION HAVE TO BE CONSIDERED IN THE LIGHT OF THEIR POTENTIAL TO BECOME STANDARDS TO WHICH REFERENCE MAY BE MADE IN NATIONAL REGULATIONS.

iTeh Standards
(<https://standards.iteh.ai>)
Document Preview

[ISO/FDIS 4766](https://standards.iteh.ai/catalog/standards/iso/fa581490-b199-4068-8ae3-e770766ce6cf/iso-fdis-4766)

<https://standards.iteh.ai/catalog/standards/iso/fa581490-b199-4068-8ae3-e770766ce6cf/iso-fdis-4766>



COPYRIGHT PROTECTED DOCUMENT

© ISO 2024

All rights reserved. Unless otherwise specified, or required in the context of its implementation, no part of this publication may be reproduced or utilized otherwise in any form or by any means, electronic or mechanical, including photocopying, or posting on the internet or an intranet, without prior written permission. Permission can be requested from either ISO at the address below or ISO's member body in the country of the requester.

ISO copyright office
CP 401 • Ch. de Blandonnet 8
CH-1214 Vernier, Geneva
Phone: +41 22 749 01 11
Email: copyright@iso.org
Website: www.iso.org

Published in Switzerland

Contents

Page

Foreword.....	iv
1 Scope.....	1
2 Normative references.....	1
3 Terms and definitions.....	1
4 Dimensions.....	2
5 Requirements and reference International Standards.....	3
6 Marking and labelling.....	4
6.1 Marking on product.....	4
6.2 Labelling on package.....	4
7 Designation.....	5
Bibliography.....	6

iTeh Standards
(<https://standards.itih.ai>)
Document Preview

[ISO/FDIS 4766](#)

<https://standards.itih.ai/catalog/standards/iso/fa581490-b199-4068-8ae3-e770766ce6cf/iso-fdis-4766>

Foreword

ISO (the International Organization for Standardization) is a worldwide federation of national standards bodies (ISO member bodies). The work of preparing International Standards is normally carried out through ISO technical committees. Each member body interested in a subject for which a technical committee has been established has the right to be represented on that committee. International organizations, governmental and non-governmental, in liaison with ISO, also take part in the work. ISO collaborates closely with the International Electrotechnical Commission (IEC) on all matters of electrotechnical standardization.

The procedures used to develop this document and those intended for its further maintenance are described in the ISO/IEC Directives, Part 1. In particular, the different approval criteria needed for the different types of ISO document should be noted. This document was drafted in accordance with the editorial rules of the ISO/IEC Directives, Part 2 (see www.iso.org/directives).

ISO draws attention to the possibility that the implementation of this document may involve the use of (a) patent(s). ISO takes no position concerning the evidence, validity or applicability of any claimed patent rights in respect thereof. As of the date of publication of this document, ISO had not received notice of (a) patent(s) which may be required to implement this document. However, implementers are cautioned that this may not represent the latest information, which may be obtained from the patent database available at www.iso.org/patents. ISO shall not be held responsible for identifying any or all such patent rights.

Any trade name used in this document is information given for the convenience of users and does not constitute an endorsement.

For an explanation of the voluntary nature of standards, the meaning of ISO specific terms and expressions related to conformity assessment, as well as information about ISO's adherence to the World Trade Organization (WTO) principles in the Technical Barriers to Trade (TBT), see www.iso.org/iso/foreword.html.

This document was prepared by Technical Committee ISO/TC 2, *Fasteners*, Subcommittee SC 11, *Fasteners with metric external thread*, in collaboration with the European Committee for Standardization (CEN) Technical Committee CEN/TC 185, *Fasteners*, in accordance with the Agreement on technical cooperation between ISO and CEN (Vienna Agreement).

This third edition cancels and replaces the second edition (ISO 4766:2011), which has been technically revised.

ISO/FDIS 4766

<https://standards.iteh.ai/catalog/standards/iso/fa581490-b199-4068-8ae3-e770766ce6cf/iso-fdis-4766>

The main changes are as follows:

- for M2, $l = 2$ mm has been classified as too short length; M8 ($l = 8$ mm), M10 ($l = 10$ mm) and M12 ($l = 12$ mm) have been classified separately as short standard lengths with l_{nom} calculated in order to get at least 2,5 full pitches; for regular standard lengths l_{nom} have been calculated in order to get at least 4 full pitches;
- for stainless steel screws, grades A2 and A4 with hardness classes 12H and 21H have been added;
- non-ferrous metal screws have been deleted (as a consequence of the withdrawal of ISO 8839);
- mechanical properties of steel and stainless steel screws have been added for $d < 1,6$ mm (“As agreed”) in [Table 3](#);
- for stainless steel fasteners, “As processed” has been changed to “Clean and bright”, and “Passivated” has been added in [Table 3](#);
- specifications for marking and labelling have been added as [Clause 6](#).

Any feedback or questions on this document should be directed to the user's national standards body. A complete listing of these bodies can be found at www.iso.org/members.html.

Fasteners — Slotted set screws with flat point

1 Scope

This document specifies the characteristics of slotted set screws with flat point, in steel and stainless steel, with metric coarse pitch threads M1,2 to M12, and with product grade A.

If in certain cases other specifications are requested, hardness classes and stainless steel grades can be selected from ISO 898-5 or ISO 3506-3, and dimensional options from ISO 888, ISO 965-1 or ISO 4753.

2 Normative references

The following documents are referred to in the text in such a way that some or all of their content constitutes requirements of this document. For dated references, only the edition cited applies. For undated references, the latest edition of the referenced document (including any amendments) applies.

ISO 225, *Fasteners — Bolts, screws, studs and nuts — Symbols and descriptions of dimensions*

ISO 724, *ISO general purpose metric screw threads — Basic dimensions*

ISO 888, *Bolts, screws and studs — Nominal lengths, and thread lengths for general purpose bolts*

ISO 898-5, *Mechanical properties of fasteners made of carbon steel and alloy steel — Part 5: Set screws and similar threaded fasteners with specified hardness classes — Coarse thread and fine pitch thread*

ISO 965-1, *ISO general purpose metric screw threads — Tolerances — Part 1: Principles and basic data*

ISO 1891-4, *Fasteners — Vocabulary — Part 4: Control, inspection, delivery, acceptance and quality*

ISO 3269, *Fasteners — Acceptance inspection* [ISO/FDIS 4766](https://standards.iteh.ai/catalog/standards/iso/fa581490-b199-4068-8ae3-e770766ce6cf/iso-fdis-4766)

<https://standards.iteh.ai/catalog/standards/iso/fa581490-b199-4068-8ae3-e770766ce6cf/iso-fdis-4766>
ISO 3506-3, *Mechanical properties of corrosion-resistant stainless steel fasteners — Part 3: Set screws and similar fasteners not under tensile stress*

ISO 4042, *Fasteners — Electroplated coating systems*

ISO 4753, *Fasteners — Ends of parts with external ISO metric thread*

ISO 4759-1, *Tolerances for fasteners — Part 1: Bolts, screws, studs and nuts — Product grades A, B and C*

ISO 6157-1, *Fasteners — Surface discontinuities — Part 1: Bolts, screws and studs for general requirements*

ISO 8991, *Designation system for fasteners*

ISO 8992, *Fasteners — General requirements for bolts, screws, studs and nuts*

ISO 10683, *Fasteners — Non-electrolytically applied zinc flake coating systems*

3 Terms and definitions

No terms and definitions are listed in this document.

ISO and IEC maintain terminological databases for use in standardization at the following addresses:

— ISO Online browsing platform: available at <https://www.iso.org/obp>

— IEC Electropedia: available at <https://www.electropedia.org/>

4 Dimensions

Dimensions shall be in accordance with [Figure 1](#) and with [Tables 1](#) and [2](#).

Symbols and descriptions of dimensions are specified in ISO 225.

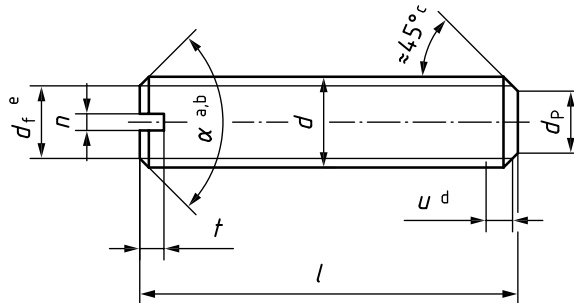

- a For regular standard lengths, α_{ref} shall be 90° or 120° at the choice of the manufacturer.
- b For short standard lengths (see Footnote a in [Table 1](#)), α_{ref} shall be 120° .
- c The 45° angle applies only to the portion of the point below the minor diameter of the thread.
- d Incomplete thread $u \leq 2P$.
- e d_f is the diameter of the chamfer at the end on the slotted side.

Figure 1 — Slotted set screw with flat point

Table 1 — Dimensions

Dimensions in millimetres

Thread, d	M1,2	M1,6	M2	M2,5	M3	(M3,5)	M4	M5	M6	M8	M10	M12
P^a	0,25	0,35	0,4	0,45	0,5	0,6	0,7	0,8	1	1,25	1,5	1,75
d_f min.	\approx Minor thread diameter d_3^b											
d_p max.	0,60	0,80	1,00	1,50	2,00	2,20	2,50	3,50	4,00	5,50	7,00	8,50
d_p min.	0,46	0,66	0,86	1,25	1,75	1,95	2,25	3,20	3,70	5,20	6,64	8,14
n nom.	0,2	0,25	0,25	0,4	0,4	0,5	0,6	0,8	1	1,2	1,6	2
n max.	0,40	0,45	0,45	0,60	0,60	0,70	0,80	1,00	1,20	1,51	1,91	2,31
n min.	0,26	0,31	0,31	0,46	0,46	0,56	0,66	0,86	1,06	1,26	1,66	2,06
t max.	0,52	0,74	0,84	0,95	1,05	1,21	1,42	1,63	2,00	2,50	3,00	3,60
t min.	0,40	0,56	0,64	0,72	0,80	0,96	1,12	1,28	1,60	2,00	2,40	2,80

NOTE The size shown in brackets is non-preferred.

^a P is the pitch of the thread.

^b The minor thread diameter d_3 is specified in ISO 724.