**Agricultural irrigation equipment —
Water-driven chemical injector pumps**

*Matériel agricole d'irrigation — Pompes doseuses à moteur
hydraulique pour l'injection de produits chimiques*

iTeh STANDARD PREVIEW
(standards.iteh.ai)

[ISO/PRF 13457](https://standards.iteh.ai/catalog/standards/sist/55d9e7fb-d25c-4ebf-bc86-4b5f9349f3fc/iso-prf-13457)

<https://standards.iteh.ai/catalog/standards/sist/55d9e7fb-d25c-4ebf-bc86-4b5f9349f3fc/iso-prf-13457>

PROOF / ÉPREUVE



iTeh STANDARD PREVIEW (standards.iteh.ai)

ISO/PRF 13457

<https://standards.iteh.ai/catalog/standards/sist/55d9e7fb-d25c-4ebf-bc86-4b59349f3fc/iso-prf-13457>



COPYRIGHT PROTECTED DOCUMENT

© ISO 2021

All rights reserved. Unless otherwise specified, or required in the context of its implementation, no part of this publication may be reproduced or utilized otherwise in any form or by any means, electronic or mechanical, including photocopying, or posting on the internet or an intranet, without prior written permission. Permission can be requested from either ISO at the address below or ISO's member body in the country of the requester.

ISO copyright office
CP 401 • Ch. de Blandonnet 8
CH-1214 Vernier, Geneva
Phone: +41 22 749 01 11
Email: copyright@iso.org
Website: www.iso.org

Published in Switzerland

Contents

| | Page |
|--|-----------|
| Foreword | iv |
| 1 Scope | 1 |
| 2 Normative references | 1 |
| 3 Terms and definitions | 1 |
| 4 Classification | 4 |
| 4.1 Classification according to installation type | 4 |
| 4.2 Classification according to mixing ratio | 5 |
| 5 Marking | 5 |
| 6 Technical characteristics | 6 |
| 6.1 General | 6 |
| 6.2 Materials | 6 |
| 6.3 Connection of a water-driven injector pump to an irrigation system | 6 |
| 7 Mechanical and function tests | 7 |
| 7.1 General | 7 |
| 7.2 Test of resistance to pressure | 7 |
| 7.3 Test of watertightness of check valves | 7 |
| 7.4 Test of range of working pressure | 7 |
| 7.5 Test of resistance to draining | 8 |
| 7.6 Test of injection rate as a function of inlet pressure | 8 |
| 7.7 Drive water ratio test | 9 |
| 7.8 Test of injection rate for proportional water-driven injector pump | 9 |
| 7.9 Test of head loss for in-line water-driven injector pump | 9 |
| 8 Durability | 10 |
| 9 Information to be supplied by the manufacturer | 11 |
| Bibliography | 12 |

Foreword

ISO (the International Organization for Standardization) is a worldwide federation of national standards bodies (ISO member bodies). The work of preparing International Standards is normally carried out through ISO technical committees. Each member body interested in a subject for which a technical committee has been established has the right to be represented on that committee. International organizations, governmental and non-governmental, in liaison with ISO, also take part in the work. ISO collaborates closely with the International Electrotechnical Commission (IEC) on all matters of electrotechnical standardization.

The procedures used to develop this document and those intended for its further maintenance are described in the ISO/IEC Directives, Part 1. In particular, the different approval criteria needed for the different types of ISO documents should be noted. This document was drafted in accordance with the editorial rules of the ISO/IEC Directives, Part 2 (see www.iso.org/directives).

Attention is drawn to the possibility that some of the elements of this document may be the subject of patent rights. ISO shall not be held responsible for identifying any or all such patent rights. Details of any patent rights identified during the development of the document will be in the Introduction and/or on the ISO list of patent declarations received (see www.iso.org/patents).

Any trade name used in this document is information given for the convenience of users and does not constitute an endorsement.

For an explanation of the voluntary nature of standards, the meaning of ISO specific terms and expressions related to conformity assessment, as well as information about ISO's adherence to the World Trade Organization (WTO) principles in the Technical Barriers to Trade (TBT), see www.iso.org/iso/foreword.html.

This document was prepared by Technical Committee ISO/TC 23, *Tractors and machinery for agriculture and forestry*, Subcommittee SC 18, *Irrigation and drainage equipment and systems*.

This third edition cancels and replaces the second edition (ISO 13457:2008), which has been technically revised.

The main changes compared to the previous edition are as follows:

- the definitions have been updated;
- in [6.2](#), a new requirement has been added: Waterways that are not opaque shall be UV resistant if uncovered;
- in [Clause 8](#), the test method has been modified: both irrigation and injection water are filtered with a 100 µm filter element (instead of a 120 µm filter element).

Any feedback or questions on this document should be directed to the user's national standards body. A complete listing of these bodies can be found at www.iso.org/members.html.

Agricultural irrigation equipment — Water-driven chemical injector pumps

1 Scope

This document specifies the construction, operational requirements and test methods for water-driven chemical injector pumps (hereinafter, water-driven injector pumps). These water-driven injector pumps are used to inject chemicals into irrigation systems. The chemicals include liquid fertilizers and solutions of fertilizers and other soluble agricultural chemicals such as acids and pesticides.

This document is applicable to water-driven injector pumps intended to operate at water temperatures of up to 50 °C and with the types and concentrations of chemicals routinely applied in irrigation.

It does not cover the function of backflow prevention devices, nor is it applicable to water-driven devices for injecting chemicals into an irrigation system operating on the basis of the Venturi principle.

2 Normative references

The following documents are referred to in the text in such a way that some or all of their content constitutes requirements of this document. For dated references, only the edition cited applies. For undated references, the latest edition of the referenced document (including any amendments) applies.

ISO 7-1, *Pipe threads where pressure-tight joints are made on the threads — Part 1: Dimensions, tolerances and designation*

[ISO/PRF 13457](https://standards.iteh.ai/ISO/PRF/13457)

ISO 7005-1, *Pipe flanges — Part 1: Steel flanges for industrial and general service piping systems*

<https://standards.iteh.ai/ISO/7005-1>

ISO 7005-2, *Metallic flanges — Part 2: Cast iron flanges*

3 Terms and definitions

For the purposes of this document, the following terms and definitions.

ISO and IEC maintain terminological databases for use in standardization at the following addresses:

— ISO Online browsing platform: available at <https://www.iso.org/obp>

— IEC Electropedia: available at <https://www.electropedia.org/>

3.1

water-driven chemical injector pump

water-driven injector pump

hydraulic pump intended to inject *chemicals* (3.12) into an irrigation system, powered by a single source energy supplied by irrigation water through a hydraulic motor, such as a piston or turbine

3.2

nominal size

numerical designation used to define the nominal size of the connection of the *water-driven injector pump* (3.1) to the irrigation system, by means of threads, flanges or other connecting device

**3.3
minimum working pressure**

P_{\min}
lowest pressure immediately upstream from a *water-driven injector pump* (3.1), following the manufacturer information, to ensure continuous operation and functionality specific to the device

Note 1 to entry: See [Clause 9](#) b) 14) for manufacturer information.

**3.4
maximum working pressure**

P_{\max}
highest pressure immediately upstream from a *water-driven injector pump* (3.1), following the manufacturer information, to ensure continuous operation and functionality specific to the device

Note 1 to entry: See [Clause 9](#) b) 14) for manufacturer information.

**3.5
range of working pressures**

all of the pressures between the *minimum working pressure* (3.3) and the *maximum working pressure* (3.4)

**3.6
drive water**

irrigation water used to operate an *on-line water-driven injector pump* (3.19) which is either ejected or returned to the irrigation system after use in the operative function

**3.7
drive water flow rate**

rate of flow of drive water used to operate an *on-line water-driven injector pump* (3.19)

**3.8
drive water ratio**

ratio of one unit volume of injected chemical to the volume of drive water required to inject one unit volume of chemical

**3.9
drive water flow range**

range of flow between minimum and maximum flows stated by the manufacturer to be appropriate for operating the pump

**3.10
irrigation water flow rate**

flow rate of irrigation water through the body of an *in-line water-driven injector pump* (3.18) or through the irrigation system to which an *on-line water-driven injector pump* (3.19) is connected in parallel

**3.11
injection rate
pumping rate**

flow rate of a *chemical* (3.12) injected into an irrigation system during operation of a *water-driven injector pump* (3.1)

**3.12
chemical**

liquid fertilizers, solutions of fertilizers or other soluble substances, such as acids, pesticides and herbicides, used in agriculture in liquid, solution or water-soluble form, normally applied through or otherwise injected into an irrigation system

**3.13
chemical solution**

water in which one or more *chemicals* (3.12) have been dissolved or diluted

iTeh STANDARD PREVIEW
(standards.iteh.ai)

ISO/PRF 13457

<https://standards.iteh.ai/catalog/standards/sist/55d9e7fb-d25c-4ebf-bc86-abf0168364d7>

3.14**irrigation system water flow rate**

sum of the *irrigation water flow rate* (3.10) and the *injection rate* (3.11)

3.15**mixing ratio**

ratio of *injection rate* (3.11) of a *water-driven injector pump* (3.1) or a chemical injection tank unit to *irrigation system water flow rate* (3.14)

Note 1 to entry: For example, an injection rate of 1 l/h into an irrigation water flow rate of 199 l/h gives an irrigation system water flow rate of 200 l/h, and a mixing ratio of 1:200.

3.16**stroke volume****pulse volume**

volume of *chemical solution* (3.13) injected into an irrigation system in one water-driven injector pump cycle

3.17**proportional water-driven injector pump**

water-driven injector pump (3.1) intended to maintain a relatively constant *mixing ratio* (3.15) throughout the period of its operation at the *irrigation water flow rates* (3.10) declared by the manufacturer

3.18**in-line water-driven injector pump**

water-driven injector pump (3.1) installed in the main irrigation system piping or in bypass piping

Note 1 to entry: See [Figure 1](#).

(standards.iteh.ai)

3.19**on-line water-driven injector pump**

water-driven injector pump (3.1) installed off the main irrigation system piping

Note 1 to entry: See [Figure 2](#).

3.20**chemical storage tank**

container for storing *chemicals* (3.12) and supplying them to a *water-driven injector pump* (3.1)

3.21**maximum suction head**

maximal distance between the centreline of the outlet of the *water-driven injector pump* (3.1) and the lowest level of the *chemical* (3.12) in the storage tank

4 Classification

4.1 Classification according to installation type

4.1.1 In-line water-driven injector pump (see Figure 1)

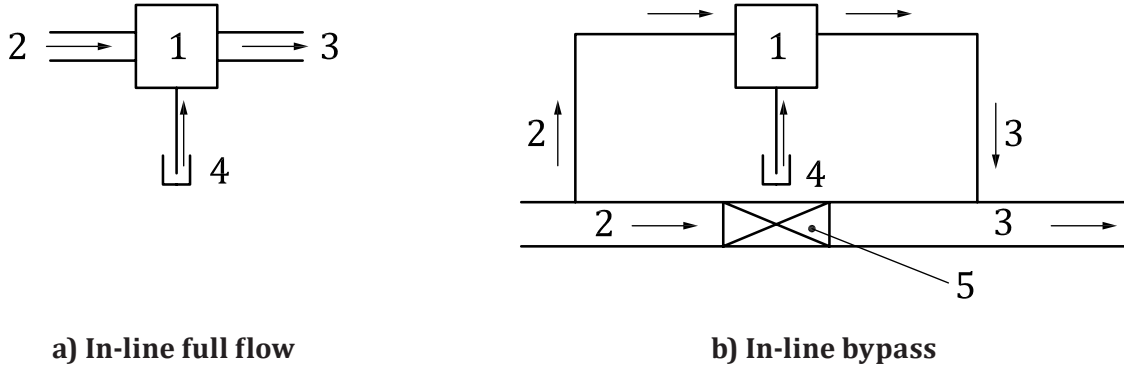

Key

- 1 injector pump
- 2 inlet for irrigation water
- 3 outlet for irrigation water with injected chemicals
- 4 inlet for chemicals
- 5 valve

iTeh STANDARD PREVIEW
(standards.iteh.ai)

NOTE 1 The arrows denote the flow direction.

NOTE 2 The injection of a chemical occurs inside the water-driven injector pump.
<https://standards.iteh.ai/catalog/standards/sist/55d9e7fb-d25c-4ebf-bc86-4b5f9349f3fc/iso-prf-13457>

Figure 1 — In-line water-driven injector pump

4.1.1.1 Full flow installation

4.1.1.2 Bypass flow installation

4.1.2 On-line water-driven injector pump (see Figure 2)

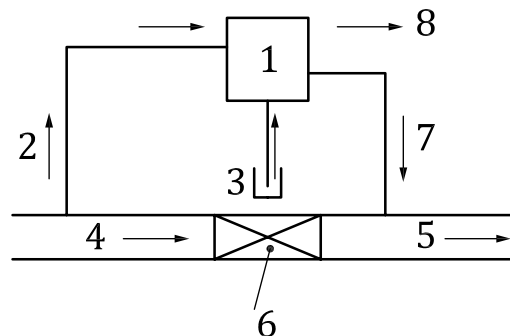

Key

| | | | |
|---|-----------------------|---|--|
| 1 | injector pump | 5 | irrigation water with injected chemicals |
| 2 | inlet for drive water | 6 | check valve |
| 3 | inlet for chemicals | 7 | outlet for chemicals |
| 4 | irrigation flow | 8 | outlet for drive water |

NOTE 1 The arrows denote the flow direction.

NOTE 2 The injection of a chemical into the irrigation water occurs outside the water-driven injector pump. The outlet for the chemical is intended to be connected to the main irrigation system piping. The drive water from the drive water outlet cannot be returned to the main irrigation system piping.

NOTE 3 The drive water can be ejected from the water-driven injector pump as shown or returned to the irrigation system (see Figure 1).

ISO/PRF 13457

<https://standards.iteh.ai/catalog/standards/sist/55d9e7fb-d25c-4ebf-bc86-409d34715c10/iso-prf-13457>

Figure 2 — On-line water-driven injector pump

4.2 Classification according to mixing ratio

4.2.1 Proportional water-driven injector pump

4.2.1.1 Fixed mixing ratio

4.2.1.2 Adjustable mixing ratio

4.2.2 Non-proportional water-driven injector pump

5 Marking

The water-driven injector pump shall bear a clear, legible and durable marking giving the following information:

- name of the manufacturer or the manufacturer's trademark;
- nominal size;
- maximum working pressure (p_{max});
- model number identical with that given in the manufacturer's catalogue;
- year of production or a mark identifying the production series;

- f) arrows indicating the direction of flow of water and chemicals into and out of the water-driven injector pump.

6 Technical characteristics

6.1 General

The water-driven injector pump shall employ means, such as a vacuum breaker valve, to prevent emptying of the chemical storage tank to the irrigation system through the water-driven injector pump in the event that the pressure in the water-driven injector pump falls below the pressure in the chemical storage tank.

The water-driven injector pump shall employ means, such as a check valve, to prevent irrigation water passing through the water-driven injector pump from entering the chemical storage tank.

It shall be possible to disassemble and clean those parts of the water-driven injector pump subject to clogging by the chemicals or by debris in the irrigation water. These parts may be fitted with a suitable filtration device accessible for the purpose of cleaning.

For on-line water-driven injector pumps (4.1.2), in which there is water loss due to the ejection of drive water out of the pump, the outlet through which the drive water is ejected shall be fitted with suitable means, such as a thread or a connector, to enable connection of a pipe for draining the outflow of drive water away from the pump.

NOTE For backflow prevention, refer to the specific requirements of each country.

6.2 Materials

Plastic parts of a water-driven injector pump that are exposed to ultraviolet (UV) radiation under normal field operating conditions shall include additives to improve their resistance to UV radiation.

Plastic parts that enclose waterways shall be opaque or shall be provided with an opaque cover designed to block all light from reaching clear waterway enclosures. Waterways that are not opaque shall be UV resistant if uncovered.

Plastic pipes conveying chemicals may be transparent and may be exposed to light.

All parts of a water-driven injector pump shall be resistant to, or protected from, those chemicals in concentrations approved or recommended for injection into irrigation systems, except as indicated in the manufacturer's literature.

6.3 Connection of a water-driven injector pump to an irrigation system

A water-driven injector pump shall be connected to an irrigation system by one of the following means:

- a) threads in accordance with ISO 7-1, except that other threads shall be allowed, provided that a suitable adapter is supplied with each threaded connection;
- b) cast-iron flanges in accordance with ISO 7005-2 or steel flanges in accordance with ISO 7005-1, with flanges made of other materials required to comply with the assembly dimensions (diameter of the distributing circle, number of holes) specified in ISO 7005-2;
- c) compression, grooved-end or other special fittings, such as plastic fittings.