



SLOVENSKI STANDARD SIST ISO 2965:1998

01-februar-1998

A UHYf]U]ži dcfUV`Yb]`_chWV[UfYfb]`dUd]f`fžni bUb]`]b`bcfUb]`VW[UfYfb]`dUd]f`fž_]`
cj]`Uc`Z`hYf`!`8`c`c` Ub`Y`nfU` bY`dfYdi`gfbcgH]

Materials used as cigarette papers, filter plug wrap and filter joining paper, including materials having an oriented permeable zone -- Determination of air permeability

iTeh STANDARD PREVIEW

Matériaux utilisés comme papier à cigarettes, pour le gainage des filtres et comme papier manchette, y compris les matériaux possédant une zone perméable orientée -- Détermination de la perméabilité à l'air

[SIST ISO 2965:1998](https://standards.iteh.ai/catalog/standards/sist/f87ee0c4-b8c6-4a23-9a99-35c7d652c106/sist-iso-2965-1998)

[https://standards.iteh.ai/catalog/standards/sist/f87ee0c4-b8c6-4a23-9a99-](https://standards.iteh.ai/catalog/standards/sist/f87ee0c4-b8c6-4a23-9a99-35c7d652c106/sist-iso-2965-1998)

[35c7d652c106/sist-iso-2965-1998](https://standards.iteh.ai/catalog/standards/sist/f87ee0c4-b8c6-4a23-9a99-35c7d652c106/sist-iso-2965-1998)

Ta slovenski standard je istoveten z: **ISO 2965:1997**

ICS:

65.160 V[àæ È[àæ } àæ à^| àæ Tobacco, tobacco products and related equipment
[]!^ { æ

SIST ISO 2965:1998

en

iTeh STANDARD PREVIEW
(standards.iteh.ai)

SIST ISO 2965:1998

<https://standards.iteh.ai/catalog/standards/sist/f87ee0c4-b8c6-4a23-9a99-35c7d652c106/sist-iso-2965-1998>

INTERNATIONAL STANDARD

**ISO
2965**

Second edition
1997-12-15

Materials used as cigarette papers, filter plug wrap and filter joining paper, including materials having an oriented permeable zone — Determination of air permeability

*Matériaux utilisés comme papier à cigarettes, pour le gainage des filtres et
comme papier manchette, y compris les matériaux possédant une zone
perméable orientée — Détermination de la perméabilité à l'air*

iTeh STANDARD PREVIEW
(standards.iteh.ai)

SIST ISO 2965:1998

<https://standards.iteh.ai/catalog/standards/sist/f87ee0c4-b8c6-4a23-9a99-35c7d652c106/sist-iso-2965-1998>



Reference number
ISO 2965:1997(E)

ISO 2965:1997(E)

Foreword

ISO (the International Organization for Standardization) is a worldwide federation of national standards bodies (ISO member bodies). The work of preparing International Standards is normally carried out through ISO technical committees. Each member body interested in a subject for which a technical committee has been established has the right to be represented on that committee. International organizations, governmental and non-governmental, in liaison with ISO, also take part in the work. ISO collaborates closely with the International Electrotechnical Commission (IEC) on all matters of electrotechnical standardization.

Draft International Standards adopted by the technical committees are circulated to the member bodies for voting. Publication as an International Standard requires approval by at least 75 % of the member bodies casting a vote.

International Standard ISO 2965 was prepared by Technical Committee ISO/TC 126, *Tobacco and tobacco products*, Subcommittee SC 1, *Physical and dimensional tests*.

This second edition cancels and replaces the first edition (ISO 2965:1979), which has been technically revised.

Annexes A and B form an integral part of this International Standard. Annexes C to E are for information only.

© ISO 1997

All rights reserved. Unless otherwise specified, no part of this publication may be reproduced or utilized in any form or by any means, electronic or mechanical, including photocopying and microfilm, without permission in writing from the publisher.

International Organization for Standardization
Case postale 56 • CH-1211 Genève 20 • Switzerland
Internet central@iso.ch
X.400 c=ch; a=400net; p=iso; o=isocs; s=central

Printed in Switzerland

Introduction

Measurements of air permeability of materials used as cigarette papers have been made for many years. The methods have required development and change because of the changing nature of the paper products and changes in the magnitude of their air permeability.

This method has been developed with the technical resources of CORESTA (Cooperative Centre for Research Relative to Tobacco).

iTeh STANDARD PREVIEW (standards.iteh.ai)

[SIST ISO 2965:1998](https://standards.iteh.ai/catalog/standards/sist/f87ee0c4-b8c6-4a23-9a99-35c7d652c106/sist-iso-2965-1998)

<https://standards.iteh.ai/catalog/standards/sist/f87ee0c4-b8c6-4a23-9a99-35c7d652c106/sist-iso-2965-1998>

iTeh STANDARD PREVIEW
(standards.iteh.ai)

SIST ISO 2965:1998

<https://standards.iteh.ai/catalog/standards/sist/f87ee0c4-b8c6-4a23-9a99-35c7d652c106/sist-iso-2965-1998>

Materials used as cigarette papers, filter plug wrap and filter joining paper, including materials having an oriented permeable zone — Determination of air permeability

1 Scope

This International Standard specifies a method for the determination of air permeability (AP).

It is applicable to materials used as cigarette papers, filter plug wrap and filter joining paper, including materials having an oriented permeable zone, where the measured permeability is in excess of $10 \text{ cm}^3 \cdot (\text{min}^{-1} \cdot \text{cm}^{-2})$ at 1 kPa.

NOTE — For an estimate of the air permeability of materials outside the scope of this International Standard, see note in 5.1 and note 3 in 7.5.1.

[SIST ISO 2965:1998](https://standards.iteh.ai/catalog/standards/sist/f87ee0c4-b8c6-4a23-9a99-35c7d652c106/sist-iso-2965-1998)

<https://standards.iteh.ai/catalog/standards/sist/f87ee0c4-b8c6-4a23-9a99-35c7d652c106/sist-iso-2965-1998>

2 Normative references

The following standards contain provisions which, through reference in this text, constitute provisions of this International Standard. At the time of publication, the editions indicated were valid. All standards are subject to revision, and parties to agreements based on this International Standard are encouraged to investigate the possibility of applying the most recent editions of the standards indicated below. Members of IEC and ISO maintain registers of currently valid International standards.

ISO 3402:1991, *Tobacco and tobacco products — Atmosphere for conditioning and testing*.

ISO 187:1990, *Paper board and pulps — Standard atmosphere for conditioning and testing and procedure for monitoring the atmosphere and conditioning of samples*.

3 Definitions

For the purposes of this International Standard the following definitions apply.

3.1

air permeability (AP)

flow of air ($\text{cm}^3 \cdot \text{min}^{-1}$) passing through 1 cm^2 surface of the test piece at a measuring pressure of 1,00 kPa

NOTE — The air permeability units are $\text{cm}^3 \cdot (\text{min}^{-1} \cdot \text{cm}^{-2})$ at 1 kPa.

3.2**measuring pressure**

difference in pressure across the two faces of the test piece during the measurement

3.3**leakage**

air flow unintentionally aspirated from the surrounding atmosphere or escaping into it through the sealing surface of the test piece holder and elsewhere

4 Principle

A test piece is held in a suitable device. A pressure difference is applied across the test piece. The resultant flow of air through the test piece is measured.

The principle of measurement is illustrated in figure 1.

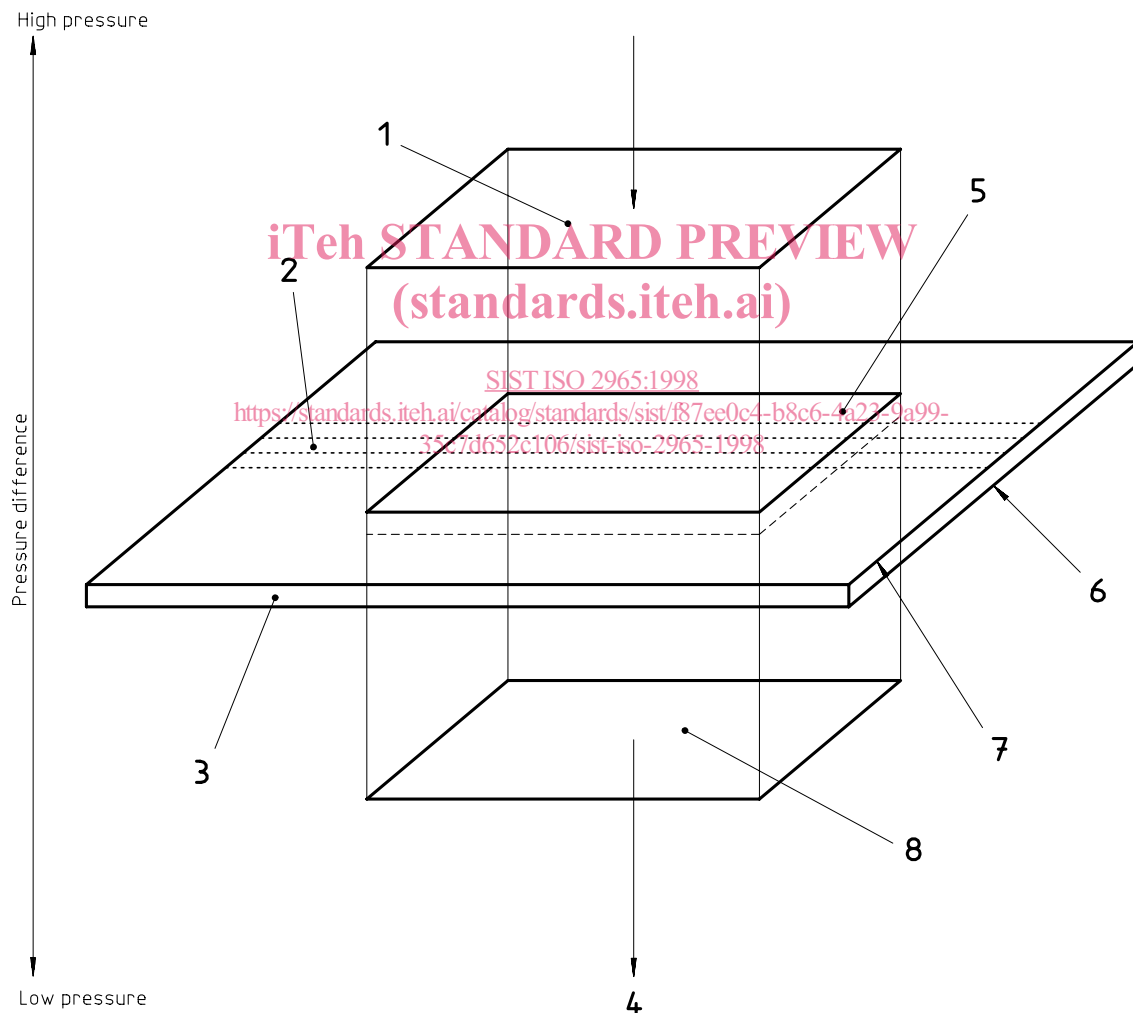

- | | |
|--------------------------------|--|
| 1 Air stream | 5 Test surface of area 2 cm ² |
| 2 Perforated zone (if present) | 6 Inner surface |
| 3 Test piece | 7 Outer surface |
| 4 Direction of air flow | 8 Air stream |

Figure 1 — Principle of measurement

The air flow through the test piece may be produced by applying a positive or negative pressure to one side of the test piece. The direction of air flow through the test piece shall be that which would occur when the sample is used in the finished product, where known, i.e. from the outside face towards the inside face.

NOTES

1 If the air flow is produced by a positive pressure, the apparatus used should incorporate a filter which protects the test sample from contamination by oil, water and particles.

2 With certain materials, the flow through the test piece may exhibit a non-linear relationship with applied pressure drop. Thus the air flow through the test piece is determined at two pressure differences to establish whether the flow/pressure relationship across the paper is linear or non-linear. If it is non-linear a second measurement of air flow is recorded at 0,25 kPa to characterize the material fully.

3 Depending upon whether the volumetric air flow rate is measured up-stream or down-stream of the test piece, a difference of approximately 1 % of the flow rate can exist either side of the theoretical value at the centre of the test piece.

5 Apparatus

5.1 Test piece holder for clamping the test piece, free from leaks, with a rectangular surface area of $2,00 \text{ cm}^2 \pm 0,02 \text{ cm}^2$ with corner radii not greater than 0,1 cm. The long side (L) shall have a length of $2,000 \text{ cm} \pm 0,005 \text{ cm}$ (see figure 2).

NOTE — An estimate of the air permeability of speciality papers, outside the scope of this International Standard, may be required. In this case, specialized test piece holders with different surface areas may be necessary.

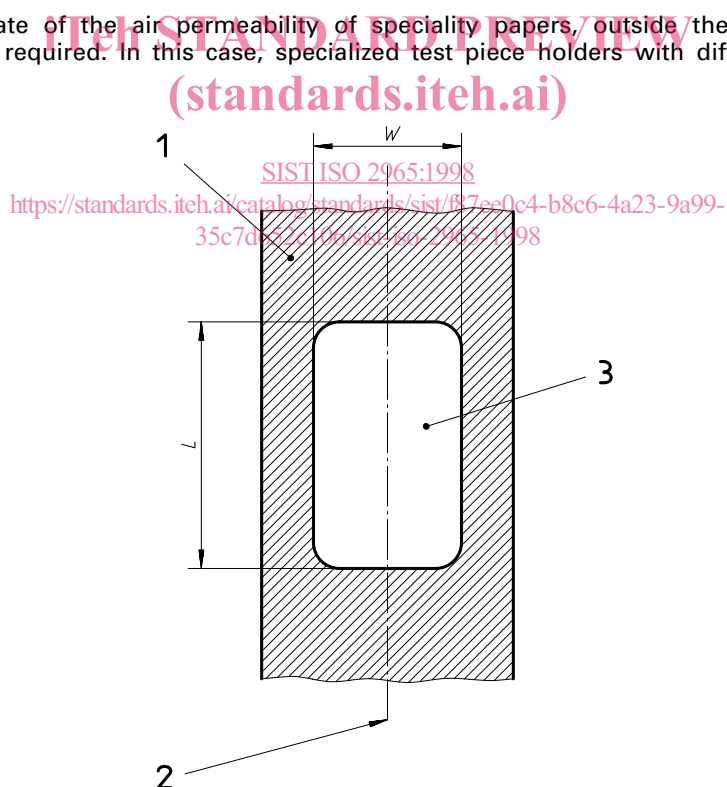

- 1 Test piece
 - 2 Centreline of test piece
 - 3 Measurement surface area of test piece holder
- W is the width of test surface
 L is the long side of test surface (see 5.1)

Figure 2 — Positioning of test pieces for materials with uniformly distributed permeability

5.2 Pneumatic controller, to produce an air flow at a given but adjustable pressure difference between the two mating faces of the test piece holder.

5.3 Pressure gauge, suitable for measuring pressure differences to at least 0,001 kPa, having a relative error of no more than 2 % of the measured value within the measuring range.

5.4 Flow meter, suitable for measuring the air flow with an relative error not greater than 5 % of the measured value within the measuring range.

5.5 Conditioning enclosure, capable of maintaining the conditions given in ISO 187 (but see 7.2).

6 Sampling

Take a sample which is representative, on a statistical basis, of the population to be characterized.

Samples shall be free of visible defects and creases which may impair measurement performance.

7 Procedure

iTeh STANDARD PREVIEW
(standards.iteh.ai)

7.1 Leak check of the test piece holder

Follow the procedure given in annex A. Perform a leak check daily, prior to use.

[https://standards.iteh.ai/catalog/standards/sist/f87ee0c4-b8c6-4a23-9a99-](https://standards.iteh.ai/catalog/standards/sist/f87ee0c4-b8c6-4a23-9a99-35c7d652c106/sist-iso-2965-1998)

Air leaks between the mating faces of the test piece holder shall not be greater than $2,0 \text{ cm}^3 \cdot \text{min}^{-1}$.

NOTE — Some users require determination of the effect of surface leakage through particular papers which contribute to the measured flow. In this case if a value for leakage, with the test piece in place, is required the procedure given in annex C may be used. This should be determined and referred to in the test report.

7.2 Preparation of test pieces

Select at random from the sample, taken in accordance with clause 6, the number of test pieces required for the test plus an additional three test pieces to be used as described in 7.5.1, note 3.

If necessary make the test pieces suitable for testing (cut to the required dimensions, eliminate folds, seams, etc.).

Condition the test pieces, prior to measurement, in a conditioning enclosure set at $23^\circ \text{C} \pm 1^\circ \text{C}$ and $50\% \pm 2\%$ relative humidity (RH) in accordance with ISO 187. Samples shall be held such that the conditioning air has free access to all their surfaces.

IMPORTANT — In laboratories unable to use the conditions given in ISO 187, the conditions $22^\circ \text{C} \pm 1^\circ \text{C}$ and $60\% \pm 2\%$ RH given in ISO 3402 may be used. In these cases a note shall be included with the test report.

NOTE — Complete sample bobbins, where it is not possible to expose all surfaces to the conditioning atmosphere, may require an extended period of conditioning. The time required should be determined by practice and experience.

The period of time for conditioning is not given in this International Standard but the period of time retained should be reported with the results.

7.3 Calibration

Calibrate the instrument using the calibration standards and procedure referred to in annex B.

7.4 Insertion of a test piece

All papers shall be placed in the test piece holder so that the measuring air will travel from the outside face towards the inside face of the paper as it is applied in the construction of the finished product, where this is known.

The positioning of the test pieces in the test piece holder is illustrated in figure 1 (see clause 4).

7.4.1 Materials with uniformly distributed permeability

Place in such a way that, if possible, the centre of the smaller dimension (W) of the test surface is at the centre of the width of the test piece (see figure 2).

7.4.2 Materials with a narrow and oriented permeable zone

The permeable zone shall be oriented along, and parallel to, the direction of the 20 mm length of the test surface (see figure 3).

The edges of the permeable zone shall not be less than 1 mm from the edges of the test surface. Ideally the test piece should extend over each edge of the test surface by at least 3 mm. If for technical reasons this cannot be achieved (i.e. the specimen under study is less than 16 mm total width or the permeable zone is less than 4 mm from one edge of the sample), this shall be referred to in the test report.

7.5 Measurement

7.5.1 General

Insert a test piece into the test piece holder. Establish an approximate pressure difference within the range $1,0 \text{ kPa} \pm 0,05 \text{ kPa}$ across the two faces of the test piece. Accurately record this pressure and the corresponding flow rate.

NOTE 1 The permeability of test pieces can vary throughout their length. For this International Standard the mean value of 10 individual measurements is used to determine the value of air permeability of a test piece. In practice, laboratories often take a different number of measurements depending upon the application of the measurement.