



Standard Guide for Room Fire Experiments¹

This standard is issued under the fixed designation E603; the number immediately following the designation indicates the year of original adoption or, in the case of revision, the year of last revision. A number in parentheses indicates the year of last reappraisal. A superscript epsilon (ϵ) indicates an editorial change since the last revision or reappraisal.

INTRODUCTION

This guide has been written to assist those planning to conduct full-scale compartment fire experiments. There are many issues that should be resolved before such an experimental program is initiated, and this guide is written with the objective of identifying some of these issues and presenting considerations that will affect each choice of procedure.

This guide deals with any or all stages of fire growth in a compartment. Whether it is a single- or multi-room experiment, observations can be made from ignition to flashover or beyond full-room involvement.

One major reason for conducting research on room fires is to learn about the room fire buildup process so the results of standard fire test methods can be related to performance in full-scale room fires, allowing the further refinement of these test methods or development of new ones.

Another reason concerns computer fire modeling. Full-scale tests can generate data needed for modeling. Comparisons of modeling with full-scale test results can serve to validate the model.

The various results among room fire tests reflect different experimental conditions. The intent of this guide is to identify these conditions and discuss their effects so meaningful comparisons can be made among the room fire experiments conducted by various organizations.

1. Scope

1.1 This guide addresses means of conducting full-scale fire experiments that evaluate the fire-test-response characteristics of materials, products, or assemblies under actual fire conditions.

1.2 It is intended as a guide for the design of the experiment and for the use and interpretation of its results. The guide is also useful for establishing laboratory conditions that simulate a given set of fire conditions to the greatest extent possible.

1.3 This guide allows users to obtain fire-test-response characteristics of materials, products, or assemblies, which are useful data for describing or appraising their fire performance under actual fire conditions.

1.3.1 The results of experiments conducted in accordance with this guide are also useful elements for making regulatory decisions regarding fire safety requirements. The use for regulatory purposes of data obtained from experiments con-

ducted using this guide requires that certain conditions and criteria be specified by the regulating authority.

1.4 The rationale for conducting room fire experiments in accordance with this guide is shown in 1.5-1.8

1.5 Room fire experiments are a means of generating input data for computer fire models and for providing output data with which to compare modeling results.

1.6 One of the major reasons for conducting room fire experiments is as an experimental means of assessing the potential fire hazard associated with the use of a material or product in a particular application. This should be borne in mind when designing nonstandard experiments.

1.7 A rationale for conducting room fire experiments is the case when smaller-scale fire tests inadequately represent end-use applications.

1.8 A further rationale for conducting room fire experiments is to verify the results obtained with smaller scale tests, to understand the scaling parameters for such tests.

1.9 Room fire tests can be placed into four main categories: reconstruction, simulation, research, and standardization.

1.10 *This standard is used to measure and describe the response of materials, products, or assemblies to heat and flame under controlled conditions, but does not by itself*

¹ This guide is under the jurisdiction of ASTM Committee E05 on Fire Standards and is the direct responsibility of Subcommittee E05.21 on Smoke and Combustion Products.

Current edition approved April 15, 2012. Published April 2012. Originally approved in 1977. Last previous edition approved in 2007 as E603 - 07. DOI: 10.1520/E0603-12.

incorporate all factors required for fire hazard or fire risk assessment of the materials, products, or assemblies under actual fire conditions

1.11 This standard does not purport to address all of the safety concerns, if any, associated with its use. It is the responsibility of the user of this standard to establish appropriate safety and health practices and determine the applicability of regulatory limitations prior to use.

2. Referenced Documents

2.1 ASTM Standards:²

D4442 Test Methods for Direct Moisture Content Measurement of Wood and Wood-Base Materials

D4444 Test Method for Laboratory Standardization and Calibration of Hand-Held Moisture Meters

D5424 Test Method for Smoke Obscuration of Insulating Materials Contained in Electrical or Optical Fiber Cables When Burning in a Vertical Cable Tray Configuration

D5537 Test Method for Heat Release, Flame Spread, Smoke Obscuration, and Mass Loss Testing of Insulating Materials Contained in Electrical or Optical Fiber Cables When Burning in a Vertical Cable Tray Configuration

E176 Terminology of Fire Standards

E800 Guide for Measurement of Gases Present or Generated During Fires

E906 Test Method for Heat and Visible Smoke Release Rates for Materials and Products Using a Thermopile Method

E1321 Test Method for Determining Material Ignition and Flame Spread Properties

E1354 Test Method for Heat and Visible Smoke Release Rates for Materials and Products Using an Oxygen Consumption Calorimeter

E1355 Guide for Evaluating the Predictive Capability of Deterministic Fire Models

E1537 Test Method for Fire Testing of Upholstered Furniture

E1590 Test Method for Fire Testing of Mattresses

E1822 Test Method for Fire Testing of Stacked Chairs

E2067 Practice for Full-Scale Oxygen Consumption Calorimetry Fire Tests

E2257 Test Method for Room Fire Test of Wall and Ceiling Materials and Assemblies

2.2 UL Standards:³

UL 1040 Fire Test of Insulated Wall Construction

UL 1715 Fire Test of Interior Finish Material

2.3 ICBO Standards:⁴

Uniform Building Code Standard UBC 8-2 Standard Test Method for Evaluating Room Fire Growth Contribution of Textile Wallcoverings

Uniform Building Code Standard UBC 26-3 Room Fire Test Standard for Interior of Foam Plastic Systems

2.4 *FM Standard*:⁵

FM 4880 Large Scale Open Building Corner Test

2.5 *ISO Standards*:⁶

ISO 9705 Fire Tests—Full Scale Room Fire Tests for Surface Products

ISO 13943 Fire Safety—Vocabulary

ISO 17025 General Requirements for the Competence of Testing and Calibration Laboratories

GUM, Guide to the Expression of Uncertainty in Measurement

2.6 *NFPA Standards*:⁷

NFPA 265 Methods of Fire Tests for Evaluating Room Fire Growth Contribution of Textile Wall Coverings

NFPA 286 Standard Method of Tests for Evaluating Contribution of Wall and Ceiling Interior Finish to Room Fire Growth

NFPA 555 Guide on Methods for Evaluating Potential for Room Flashover

2.7 *Other Standard*:⁸

DASMA 107 -98 (03) Room Fire Test Standard for Garage Doors Using Foam Plastic Insulation

3. Terminology

3.1 Definitions:

3.1.1 For definitions of terms used in this guide and associated with fire issues, refer to the terminology contained in Terminology **E176** and **ISO 13943**. In case of conflict, the terminology in Terminology **E176** shall prevail.

3.1.2 *heat release rate, n*—the heat evolved from the specimen, per unit of time.

3.1.3 *oxygen consumption principle, n*—the expression of the relationship between the mass of oxygen consumed during combustion and the heat released.

3.1.4 *smoke obscuration, n*—reduction of light transmission by smoke, as measured by light attenuation.

3.1.5 *total heat released, n*—integrated value of the rate of heat release, for a specified time period.

3.2 Definitions of Terms Specific to This Standard:

3.2.1 *full-scale test, n*—a test in which the product(s) to be tested is utilized in the same size as in its end use.

3.2.1.1 *Discussion*—In practical applications, this term is usually applied to tests where the item to be tested is larger than would fit in a bench-scale test.

4. Summary of Guide

4.1 This guide does not define a standard room fire test. It does, however, set down many of the considerations for such a test, for example, room size and shape, ventilation, specimen

² For referenced ASTM standards, visit the ASTM website, www.astm.org, or contact ASTM Customer Service at service@astm.org. For *Annual Book of ASTM Standards* volume information, refer to the standard's Document Summary page on the ASTM website.

³ Available from Underwriters Laboratories, Inc., 333 Pfingsten Rd., Northbrook, IL 60062.

⁴ Available from International Conference of Building Officials, 5360 Workman Mill Rd. Whittier, CA 90601.

⁵ Available from Factory Mutual Research Corporation, 1151 Boston-Providence Turnpike, P.O. Box 9102, Norwood, MA 02662.

⁶ Available from International Organization for Standardization, P.O. Box 56, CH-1211, Geneva 20, Switzerland.

⁷ Available from National Fire Protection Association, Batterymarch Park, Quincy, MA 02269.

⁸ Available from Door and Access Systems Manufacturers Association International, 1300 Summer Avenue, Cleveland, OH 44115-2851.

description, ignition source, instrumentation, and safety considerations that must be decided on in the design of a room fire experiment. It discusses performance criteria for the particular array of finishing and furnishing products that comprise the room. The behavior of any particular product in the room depends on the other products and materials present and how they are arranged in relation to one another.

4.2 Whether a particular arrangement simulates the evaluation desired depends on the size and location of the ignition source. It is therefore important that the ignition source simulate, insofar as possible, an initiating fire for the desired scenario.

4.3 The main criterion suggested in this guide for evaluating fire performance is based on the time to flashover as indicated by the time at which the radiation flux at the center of the floor exceeds 20 kW/m^2 . Other suggested indicators of flashover include an average upper air temperature in excess of 600°C and the ignition of a cotton indicator. Other possible performance criteria include the total amount or rate of smoke and heat production, extent of the flame spread for a low-energy ignition source, and size of the primary ignition source required to produce flashover.

4.3.1 Where multi-room experiments are being conducted, flashover may not be an appropriate performance criteria. In fact, the experiments may have to be conducted beyond flashover. Post-flashover is usually required in the test room in order to observe high levels of toxic gases and smoke in remote rooms or flame spread in adjoining surface areas. Other performance criteria could be the levels of combustion products that impair visibility and cause incapacitation or lethality in remote rooms.

4.4 Primary ignition sources include gas burners, wood cribs, waste containers, and pools of liquid fuel. Waste containers and wood cribs have the advantage of presenting a solid fuel fire with some feedback effects and a luminous flame that appears to simulate the burning of furniture. However, the gas burner is the best choice for most fire experiments because of its reproducibility. The placement of the ignition source depends on the desired effect on the target material.

4.5 The instrumentation for measuring burning rate, heat release rate, heat flux, temperature, upper layer depth, air velocity, flame spread, smoke, and gas concentration is discussed, along with suggested locations. A minimum level of instrumentation is also suggested.

4.6 A typical compartment size is 2.4 by 3.7 m [8 by 12 ft], with a 2.4-m [8-ft] high ceiling. A standard-size doorway (0.80 by 2.0-m high) should be located in one wall, probably in one of the shorter ones. The top of the doorway should be at least 0.4 m [16 in.] down from the ceiling to partially contain smoke and hot gases.

4.7 Insofar as possible, the construction details of the wall and ceiling, as well as any enclosed insulation, should duplicate the room being simulated. Boundary surfaces that do not form the specimen should also be constructed of materials consistent with the room being simulated (see 6.2.3).

4.8 The safety of observers and the crew extinguishing the fire is emphasized strongly in this guide.

4.9 The analysis of data should include a comparison of the critical times, heat fluxes, temperatures, heat release rate, and smoke generation in the room with ignition, flame spread, and smoke properties of the specimen materials. This would aid in the development or modification of small-scale tests and would provide useful information for assisting in the development of analytical room fire models.

5. Significance and Use

5.1 This guide provides assistance for planning room fire tests. The object of each experiment is to evaluate the role of a material, product, or system in the fire growth within one or more compartments.

5.2 The relationship between laboratory fire test methods and actual room fires can be investigated by the use of full-scale and reduced-scale experiments. This guide is aimed at establishing a basis for conducting full-scale experiments for the study of room fire growth.

5.3 Room fire tests can be placed into four main categories: reconstruction, simulation, research and standardization.

5.3.1 Reconstruction room fire tests are full scale replicates of a fire scene with the geometry, materials, contents, and ignition source intended to duplicate a particular scenario. The usual purpose of such a test is to evaluate what happened or what might happen in such a scenario.

5.3.2 Simulation room fire tests are comparable to reconstruction fire tests, except that not all of the parameters are duplicated. A simulated fire test is one in which one or more components of a fire scenario are altered, usually in order to facilitate conducting the test. The compartment design must carefully address geometry and materials of construction to ensure that they do not significantly alter the fire response. Reconstruction and simulation fire tests often have a distinctive objective, such as time to flashover, that is related to the nature of the original fire scene.

5.3.3 Research room fire tests are conducted in order to elucidate the effects of one or more of the following: geometry, materials, placement of items, ventilation, or other parameters. The measured effects (such as room temperature, heat flux, heat release rate, time to flashover, post flashover conditions) are chosen to provide the most useful information.

5.3.4 Standardization room fire tests include scenarios that have been adopted by a standardization body. In this case, the compartment, ignition source, instrumentation and the nature of the contents are specified. The purpose of such a test is often the evaluation of a specific fire test response parameter. Simplified geometries and materials of construction are selected, partly because the compartment is intended to be used repeatedly. Either simulated or actual commercial test objects are specified. The geometry of the compartment is generally specified to allow well-ventilated burning of the contents, with minimal radiative feedback, and to permit observation of flame spread. In most standardized fire tests, flashover is a termination point for the test.

5.3.5 In all cases, the room lining materials should be chosen carefully. Short duration fire response tests that do not reach flashover may be less affected by lining materials than longer duration fire tests that are intended to go to flashover. The thermal properties of the lining material (emissivity,

thermal conductivity, thermal inertia) should be considered. The three main variables in compartment design must be considered for any of the types of room size fire tests: ventilation, geometry, and compartment materials (see Section 6).

6. Experimental Choices

6.1 *General*—The complete program for any series of full-scale compartment fire experiments usually involves many different considerations and possible simulations. This guide reflects the current state of knowledge and suggests choices for geometry, ignition sources, and instrumentation.

6.2 *Compartment Design*—When designing a compartment fire test, the designer should consider the purpose and the intended use of the test as one of the parameters for the compartment design.

6.2.1 Ventilation:

6.2.1.1 Experiments with ventilation-controlled fires in model rooms (1),⁹ where the fire has become large or reaches the point of flashover, show that the compartment geometry and dimension influence the burning rate. An important relationship is the following:

$$\dot{m} = kA\sqrt{H} \quad (1)$$

where:

\dot{m} = maximum mass burning rate inside the compartment (kg/s),

A = area of the ventilation opening (m²),

H = height of the ventilation opening (m), and

k = a proportionality constant, the value of which is approximately 0.09 kg/m^{5/2} s.

NOTE 1—The equation above addresses the maximum value of the mass burning rate for all items in the compartment and not the mass loss rate of an individual item.

This equation is an empirical relationship resulting from the classic ventilation-controlled wood crib fires that Kawagoe (2) studied. Other experiments by Hagglund (3) reveal that flashover was not observed for $A\sqrt{H}$ below 0.8 m^{5/2}. Hagglund conducted experiments on wood cribs in a compartment measuring 2.9 by 3.75 by 3.7-m high. These studies suggest that if the mass loss rate of fuel exceeds the mass burning rate calculated in Eq 1, then the fire is ventilation-controlled. One of the indications of a post-flashover fire is that the fire is ventilation-controlled such that part of the fuel generated will continue burning outside of the compartment. The correlation is useful as a guideline for the occurrence of flashover.

6.2.1.2 However, later studies show that the rate of burning becomes independent of ventilation at flashover. Also, a single item with a large enough burning rate can induce flashover. Among other parameters, ventilation plays an important role in fire severity. Drysdale (4) explores many of these parameters in detail.

6.2.1.3 Ventilation should be continuous in a multi-room test facility. The doors may be either open or partially closed.

One can install a typical heating ventilation and air conditioning (HVAC) duct system if the compartments are closed.

6.2.2 Geometry:

6.2.2.1 The geometry of the compartment in conjunction with the thermal properties of the wall and ceiling materials has substantial influence on the behavior of a confined fire. In particular this affects flow patterns, and hence the mixing and combustion characteristics. Thus, the compartment size, shape, and openings should be chosen to simulate the nature or type of compartment or facility in which the subject material, product, or system is expected to be used in actual service. If there is a range of sizes, account should be taken of the fact that for a given ignition exposure, the smaller compartment sizes will usually provide the most severe fire development conditions (due to re-radiation effects). However, it has been found that room size (if the floor area lies between 8.7 and 11.4 m² and one of the room floor dimensions is between 2.4 and 3.7 m) has little effect on heat development if the heat release rate is below 600 kW (5). The compartment should preferably be designed to be symmetrical and as simple as possible for ease of analysis. The ASTM room-corner test (Test Method E2257) is based on a 2.4 by 3.7-m [8 by 12-ft] room with a 2.4-m [8-ft] high ceiling. It has one standard-size doorway left fully open. The space between the top of the door and the ceiling is critical because of the trapping of smoke and hot gases. It is 0.4 m [16 in.] in the ASTM room. The room dimensions may be chosen to simulate some particular applications (see 5.3) or they may be altered when conducting a special test which requires it. If the latter, the test report should indicate that the room has been modified from the standard ASTM room. However, if there are no constraints, it is better to remain within the dimensions of the ASTM room for possible comparison with other single compartment tests. The room should be located inside a larger, carefully ventilated enclosure to ensure minimum interference from drafts or wind currents. Ref (6) shows how doorway size and room geometry affect fire growth. In order to measure many of the fire-test-response characteristics (such as heat and smoke release rates) that are required from room-sized tests, a canopy hood and exhaust duct are required, as part of a full scale oxygen consumption calorimeter, as described in Practice E2067. Such a calorimeter hood is usually placed either in the room itself, or more commonly, just outside the doorway (see Fig. 1), in order to capture the products of combustion needed to measure and calculate heat and smoke release rates.

6.2.2.2 Examples of tests that use full rooms are Test Methods D5424, D5537, E1537, E1590, E1822, E2257, NFPA 265, NFPA 286, UL 1715, UBC 8-2 (now withdrawn), UBC 26-3 (now withdrawn), ISO 9705 and DASMA 107.

6.2.2.3 In a multi-room test, it is critical to duplicate the size and location of corridors and remote rooms. If flame spread along walls is being observed, it may not matter if the corridor has a closed end; it does matter when the flame spread on the floor is important. It has been shown that closing the corridor has very important effects on gas flow and decay of gases (7, 8).

6.2.3 *Thermal and Radiative Properties of Compartment Linings:*

⁹ The boldface numbers in parentheses refer to the list of references at the end of this guide.

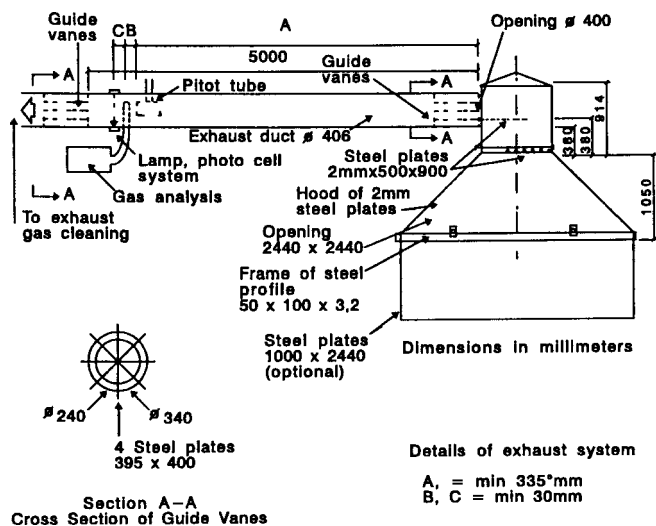

FIG. 1 Canopy Hood and Exhaust Duct

6.2.3.1 The fire gas temperature and heat flux levels in the fire compartment depend on the heat balance of the compartment (heat released during the combustion process and heat lost to the bounding surfaces and transfer of thermal energy due to the net flow of hot gas from the room through natural ventilation or forced ventilation systems. Heat transfer to a bounding surface in the presence of flames occurs mainly by radiation and convection. The amount of radiant energy impinging on a surface depends on the radiative properties of the exposure fire and of the surrounding surfaces. The convective heat transfer rate is determined by the geometry of the bounding surface and the magnitude and turbulence associated with the gas flow in the compartment. Heat transfer, which affects the magnitude of heat flux acting on the bounding surface, is related directly or indirectly to both the size and shape of the compartment involved even though radiative properties of the materials contained in bounding surfaces are unrelated to geometrical issues. Consequently, the geometry, thermal and radiative properties, and degradation characteristics of the compartment surfaces should be considered carefully when conducting compartment fire experiments.

6.2.3.2 The thermal inertia (product of thermal conductivity, density, and heat capacity, $k\rho c$) of the materials forming the linings of a fire compartment (bounding materials) directly affects their surface temperature, and its corresponding rise, the rate of heat dissipated into the internal surface, and the room gas temperature. The influence of the wall materials on the temperature distribution in the gas is also a function of the radiative properties of the gas and the gas velocity. Relevant nondimensional parameters which account for this coupled interaction have been published (9). If the thermal inertia is low (good insulation), the surface temperature rises more rapidly, the rate of heat transfer decreases, and the radiation emitted from the upper walls and ceiling to both the fire itself and the lower part of the compartment increases. The emissive power of surfaces and their temperatures are coupled through the radiative transfer equation. Bounding surfaces consisting of materials with good insulating properties will produce substantially higher gas temperatures in the room than when poor

insulators are used for lining the enclosed space. The effect of compartment thermal properties on the time-temperature curve has been analyzed mathematically in the post-flashover regime with numerical methods (10-12). Full-scale studies demonstrate the effect of compartment wall properties on the fire intensity (13-15). Typical thermal property values of some samples of common materials are given in Table 1 (16) as guidance.

6.2.3.3 The radiative characteristics of the bounding surfaces influence the compartment gas temperatures, particularly during the pre-flashover stages of compartment fires, but this effect decreases with time (10). Bounding surfaces having a greater absorptivity result in a lower gas temperature in the fire compartment. However, the surface absorptivity effect is pronounced when good thermal conducting materials are used on the walls, ceiling, and floor and is of minor practical importance for the compartment lined with high-insulation materials.

6.2.3.4 Since the severity of a fire in its early stages will depend on the heat exchange with the bounding surfaces of the room, it is important that construction details, such as the wallboard thickness, type, size, and spacing of the studs and joists, and insulation, if any, in the wall and ceiling cavities, be representative of the construction that is being simulated. For those areas of the interior surface not being tested, a suitable inert material may be a ceramic fiberboard that has thermal properties similar to those of gypsum board. (Tran and Janssens (15) have demonstrated that ceramic fiberboard is a very good insulator and can increase the severity of the test.) Gypsum and ceramic fiberboard give different results, and the results must not be intermixed. Gypsum is the material of choice for normal tests.

6.2.3.5 During the course of a compartment fire experiment, the disintegration or cracking, if any, of the materials lining the compartment will affect the behavior of the confined fire. Vertical pressure gradients developed in the presence of the fire will cause smoke and hot gases to leak to the outside and cool air to be drawn into the compartment through the cracks in the compartment walls or specimens.

6.3 Specimens:

6.3.1 General:

6.3.1.1 In the room fire experiment, all of the combustible products in the room can be considered to be part of the specimen. When some of these products are combined to form an item of furnishing or a wall, the combination becomes the specimen. In fact, the walls, ceiling, floor, and all of the furnishings constitute a configured specimen whose properties include the physical and chemical properties of the items and their location.

6.3.1.2 The following paragraphs deal with recommendations for the description and selection of specimens for the room fire experiments to ensure that the important variables will be considered, and to provide a basis of comparison between experiments conducted at different laboratories.

6.3.2 Description—As much information as possible should be secured and reported for the materials, products, and assemblies in order to provide the necessary information on the room fire specimen. Along with a description of the ventilation conditions and ignition source, the data are intended to provide

TABLE 1 Typical Thermal Property Values of Some Common Materials (to be Used for Guidance Only)

NOTE 1—The data provided in this table (Peacock, et al., NIST, 1994) defines one set of properties for common materials which are not well defined, and are provided for approximate guidance only. The numbers listed within this table cannot be assumed to fully reflect the properties of all materials within the generic class described. Data for common brick and clay brick were provided by the Brick Institute of America.

Materials, in.	Thermal Conductivity, W(m K)	Specific Heat, J/(kg K)	Density, kg/m ³	Thickness, m	Emissivity, (-)
Gypsum board, 1/2 in.	0.16	900	790	0.013	0.9
Gypsum board, 5/8 in.	0.16	900	790	0.016	0.9
Gypsum board, 3/4 in.	0.16	900	790	0.019	0.9
Gypsum wallboard, ranges	0.16–0.22	900–1047	790–400	0.024–0.050	0.90–0.97
Gypsum board, type X, 5/8 in.	0.14	900	770	0.016	0.9
Gypsum board, type X, 3 in.	0.22	1085	1680	0.076	0.9
Gypsum substrate, w. glass mat	0.16–0.04	900–720	790–10	0.024–0.050	0.9
Brick, common, 3 in.	0.72	921	1920	0.076	0.9
Clay brick, 3 in.	1.3	1004	2082	0.076	0.9
Fire brick	0.36	750	1040	0.113	0.8
Fire brick composite, range	0.17–0.36	1040	128–750	0.005–0.113	0.95
Concrete, normal weight, 6 in.	1.75	1000	2200	0.15	0.94
Cement mortar, 1 in.	0.72	780	1860	0.025	0.9
Glass plate, 1/4 in.	1.4	750	2500	0.006	0.1
Aluminum, pure, 1/8 in.	231	1033	2702	0.003	0.9
Aluminum alloy 2064-T6, 1/8 in.	186	1042	2770	0.003	0.9
Carbon steel, plain, 1/8 in.	48	559	7854	0.003	0.9
Carbon steel, plain, sheet, 1/16 in.	48	559	7854	0.0015	0.9
Stainless steel 304, 1/8 in.	19.8	557	7900	0.003	0.9
Plywood building board, 1/2 in.	0.12	1215	545	0.013	0.9
Hardwood siding, 1/2 in.	0.094	1170	640	0.013	0.9
Hardboard, high density, 1/2 in.	0.15	1380	1010	0.013	0.9
Particle board, low density, 1/2 in.	0.078	1300	590	0.013	0.9
Particle board, high density, 1/2 in.	0.17	1300	1000	0.013	0.9
Hardwoods (oak, maple), 3/4 in.	0.16	1255	720	0.019	0.9
Softwoods (fir, pine), 3/4 in.	0.12	1380	510	0.019	0.9
Wood board, shredded, cemented, 1/2 in.	0.087	1590	350	0.013	0.9
Sheathing, regular density, 1/2 in.	0.055	1300	290	0.013	0.9
Ceremic (kaolin) fiber insulation	0.22	1047	128	0.116	0.97
Glass fiber insulation, 3-1/2 in.	0.04	720	105	0.088	0.9
Glass fiber, organic bonded, 1/2 in.	0.036	795	105	0.013	0.9
Glass fiber, poured or blown, 1/2 in.	0.043	835	16	0.013	0.9
Glass fiber, coated, duct liner, 1/2 in.	0.038	835	32	0.013	0.9
Acoustic tile, 1/2 in.	0.058	1340	290	0.013	0.9
Vermiculite flakes, 1/2 in.	0.068	835	80	0.006	0.9
Urethane insulation, rigid foam, 1/2 in.	0.026	1045	70	0.013	0.9

ASTM E603-12

<https://standards.iteh.ai/catalog/standards/sist/653a63cf-1dff-4e7a-bb50-e3372c0c25e2/astm-e603-12>

the input necessary to estimate the degree of involvement of the various combustibles and the maximum rise in the upper air temperature that could potentially be attained.

6.3.2.1 The specimen should be divided into components classified either as finishing materials, wall and floor coverings, or furniture.

6.3.2.2 The location of the material, product, or assembly to be tested as a lining should be specified as in one or more of the following zones: (1) ceiling, (2) upper half of wall, (3) lower half of wall, (4) floor, or (5) fraction of a zone, for screening purposes. Both combustible and noncombustible components are to be taken into account. The test standards addressing specific items, such as Test Method E2257, NFPA 265, or NFPA 286, give details of the locations to be used.

6.3.2.3 The chemical composition, generic or brand name of the lining material, and any involved adhesive interfaces, description of exposed area, thickness, density, moisture content, and fire properties of each component should be detailed. If possible, the thermal conductivity and specific heat should also be listed. Some fundamental fire properties of the material as determined by accepted test methods such as the cone calorimeter, Test Method E1354, the OSU calorimeter, Test Method E906, or the LIFT apparatus, Test Method E1321,

reflect various aspects of the fire performance in a room fire. Data such as heat release, smoke release, ignitability, flame spread, etc. may assist in interpretation of the results of the room fire experiment. The ignition times, flame spread distance and rate, and heat release rates depend on many factors, such as the incident heat flux on the specimen and the type of flame. Hence, the exposure conditions during the room fire experiments should be described. If possible, the bench-scale fire tests should be performed on specimens that have the same thickness as the material used in the room temperature for thicknesses up to 50 mm [2 in.].

6.3.2.4 The location of items of furniture in terms of their distance from the wall, corner, and other furniture items should be identified in terms of their distance from the different walls, corners, and any other furniture items specified. For each furniture item to be tested, the horizontal and vertical exposed areas, total weight, and moisture content should also be described. It would also be helpful to indicate the material composition, if known. The test standards addressing specific items, such as Test Method E1537, for upholstered furniture or Test Method E1590, for mattresses, give details of the locations to be used.

6.3.2.5 The ambient temperature and humidity of the room and the time these conditions have been maintained prior to the experiment should be recorded.

6.3.3 *Selection*—The choice of the specimen is based on the objective of the room fire experiment, which may be one of three types: (1) a demonstration experiment, (2) a comparison of theory and experiment, or (3) a determination of the fire performance of a particular product.

6.3.3.1 In the demonstration experiment, the room should be finished and furnished in the most realistic way possible. Observations and measurements should be aimed at uncovering the important phenomena involved in the simulated room fire and at establishing possible levels of temperature, gas concentration, and times of occurrence, etc.

6.3.3.2 In the second type of room fire experiment, the emphasis is on the ease of description so that calculated values can be checked against the experimental results. The number of products in any given experiment should be minimized for simplicity of description. However, products covering a large range of properties should be selected for the tests so that the prediction formulas developed do not have limited applicability.

6.3.3.3 In the third type of experiment, to evaluate fire performance, the location of the comparison product in the room should be based on its intended use (that is, a ceiling, wall, floor, wall covering, or item of furniture). Because of heat-trapping effects, the ceiling material should cover the complete room ceiling. While it may not be necessary to cover the entire wall area with the wall product, the area covered by a wall product must be large enough to contain all wall areas exposed during the experiment and extend beyond the end of any expected flame spread. In general, other materials in the room should be noncombustible, or at least of low heat release, and should remain the same from experiment to experiment. Because of its widespread use and low heat release, gypsum board is often used, but the board must be replaced between experiments in those areas in which it was exposed to fire. An alternative is ceramic fiberboard.

6.3.3.4 The experimenter may occasionally want to evaluate the outcome of the most severe ignition source and product orientations. It would be prudent for a caveat to be added to the conclusions of the experimental report stating that other ignition source strengths and material orientations were not considered and therefore could not be evaluated on the basis of the subject experiments.

6.3.3.5 Unless special considerations apply, the relative sizes of the product to be tested and of the ignition source should be such that only a fraction of the product to be tested should be consumed, if the product to be tested has good enough fire performance.

6.3.4 *General Considerations:*

6.3.4.1 The distinction between materials located on the upper and lower walls is made because heat conduction losses occur primarily through the upper walls and ceiling. Increasing the insulation in these areas increases the rate of temperature rise in the room and the maximum temperature that will be reached.

6.3.4.2 The spacings between the items of furniture, along with the ignitability of the furniture, determine the probability and time of flame spread between them. When two or more items of furniture are burning, their separation distance determines whether the flames will merge. Furthermore, the heat transfer between them will enhance their separate burning rates so that larger flames will result. The proximity of the burning item of furniture to the wall and corner causes an increase in flame height with an attendant increase in air temperature and the probability of the flame jumping between the item and the wall.

6.3.4.3 In addition to its toxic effect and visibility problems, smoke is a factor in the heat radiative exchange between the upper and lower portions of the room. The height of the furniture items or wall covering material will determine the probability of their ignition by the hot air layer in the upper part of the room. Horizontal and vertical surface areas are therefore specified separately because of the difference in heat transfer from flames to surfaces with these orientations. These differences lead to different heat release rates and flame spread characteristics.

6.4 *Ignition Sources:*

6.4.1 *General*—The choice of a primary ignition source in a compartment fire experiment is a critical item. This guide presents a list of the important considerations for the choice. There will always be compromises on the size, location, type of fuel, time of burning, type of burning, and other factors. This discussion will present some of the important considerations and various choices that can be made.

6.4.2 *Type and Size*—The complete character of the ignition source should be determined, including weight, material identification, morphology, dimensions, and all other physical and chemical characteristics that are necessary to repeat each ignition scenario. Typical ignition sources may be solid, liquid, or gaseous fuels and include wastebaskets, furniture items, wood cribs, gas burners, liquid pool fires, and liquid fuels poured onto items of furnishings. The size is strongly dependent on the degree of fire buildup required for the experiment and the combustibility of the materials used in the experiment. When choosing an ignition source for a particular experiment, the characteristics of the product to be tested (size and heat production capability) should be taken into account, so as to make a reasonable selection.

6.4.2.1 Gas burner flames have the following characteristics: (1) they are reproducible; (2) they are well-defined (that is, their heat production rate is determined readily from the gas flow rates); (3) they can be varied with time to represent the burning of different items of furniture or be maintained constant to facilitate analytical studies; (4) their burning rates are not influenced by heat feedback (unless controlled artificially); (5) the radiation properties of the flames are different than those of the product simulated; and (6) gas flames do not resemble what is seen in real fires.

6.4.2.2 Differences between diffusion and premixed burners should be recognized. For example, the flames from a premixed burner will be shorter and have lower emissivities. In

order to avoid locally high velocities, the gas can be delivered through a large-area diffusing surface, such as a porous plate or a layer of sand.

6.4.2.3 Liquid fuel pool fires have the following characteristics: (1) their rate of fuel production is determined readily from their rate of mass loss or the flow rate necessary to maintain a constant depth in the pool; (2) they have an interaction with the fire environment that can be quantified by their change in heat production rate; (3) they are reproducible under the same exposure conditions; (4) their radiation characteristics can be controlled by the choice of fuel; (5) the effect of feedback is not quantitatively the same as that for furnishings; and (6) they lack visual realism unless they are intended to represent liquid fuel spills. A variation of the liquid pool fire is obtained by supplying the liquid fuel in a matrix of sand in order to vary its burning rate.

6.4.2.4 The solid fuels that have been used as ignition sources for room fire experiments have included primarily waste containers and wood cribs, with the latter having the longest history. Stick size, type of wood and spacing, as well as total mass have a large effect on the burning rate of the wood cribs. The use of the above two types of solid fuels is emphasized in this guide because they have been used the most up to the present time. However, the reproducibility and precisely known heat output of a gas burner makes it a likely candidate for replacement of the cribs and waste containers for standard room fire experiments when detailed heat balances must be obtained from the experiments. Waste container and wood crib fires have the following advantages: (1) they provide the best visual simulation of the burning of furniture; (2) their interaction with the environment of the fire room is perhaps closer to, though not the same as, that of the burning furniture; and (3) their radiation characteristics more nearly match those of the furniture fire. Waste containers and wood cribs have the following disadvantages: (1) their reproducibility is not as good as that of gas burners and (2) the ratio of their heat release rates to their measured mass loss rates vary throughout the test.

6.4.2.5 Both the National Institute of Standards and Technology (NIST, formerly the National Bureau of Standards (NBS)) and the University of California, Berkeley, laboratories have used plastic waste containers as ignition sources in compartment fire experiments (17, 18). The combustibles within these waste containers have been plastic-coated paper milk cartons, paper tissues, carbon paper, paper towels, or kraft wrapping paper, or some combination thereof. Plasticized paper milk cartons make a relatively intense fire, as shown by burning rate, plume temperature, and heat flux. The milk cartons represent a combination of a cellulosic and a hydrocarbon-based polymeric material with a high surface-to-volume ratio comparable to the contents of a typical waste container in an American home.

6.4.2.6 If an ignition source is kept small, so that it does not cause flashover by itself, it can then be used to determine the effect of furniture or wall, ceiling, or floor covering on fire development in that compartment. The maximum size of an ignition source that should be chosen is thus dependent on the size, shape, and ventilation of the compartment as well as the location and burning characteristics of the ignition source

itself. The size of the ignition source also depends on the scenario to be investigated.

6.4.2.7 It has been determined that the rate of heat release in a ventilation-controlled fire is proportional to $A\sqrt{H}$ (6.2.1). For a typical fire scenario, the ignition source heat release rate should be less than 15 % of that estimated to produce flashover in the burn room. The size of the ignition source should not repress the contribution of the product that is being tested. When using gas burners, or a pool fire, the flow rate can be adjusted so that it does not cause flashover by itself. Other items used as ignition sources, such as furniture, can be tested in calorimeters to determine the heat release rate prior to actual testing.

6.4.2.8 Ignition sources are characterized by the following categories: (1) total fuel content; (2) type of fuel content; (3) rate of fuel release as a function of time; (4) rate of heat release as a function of time; (5) height of flame for given position (that is, corners, wall, etc.); (6) direct use of convective and radiative heat flux; and (7) time of burning. These characteristics can be determined for a variety of ignition sources, and the compartment experiment can be initiated with the appropriate source. Then, if a given ignition source does not lead to full room involvement with a given wall lining or to burning in a piece of furniture, when the intent is to determine the threshold size of the ignition source required to produce flashover, the intensity of the ignition source can be increased for the next experiment. Typical heat release rates as a function of time for larger sources have been reported (19, 20). For more data, the user should refer to Gross (21), Babrauskas, et al. (22), Holmlund (23), and Ahonen, et al. (24).

6.4.2.9 The designer of any experiment would be wise to explore the effect of a variety of ignition sources in the experimental arrangement. A 9.1-kg [20-lb] wood crib might cause full room involvement in a very small compartment, while a 22.7-kg [50-lb] crib would be necessary for a larger compartment lined with identical material. In one set of Underwriters' Laboratories full-scale room burns (25) using a 2.4 by 3.7-m [8 by 12-ft] enclosure with a 2.4-m [8-ft] ceiling and a standard-size door opening, a 1.4-kg [3-lb] waste container located in one corner was sufficient to cause full involvement of the room when it was lined with a high flame spread foam, but not with low flame spread foams. An overstuffed chair with cotton padding was found to have a burning rate equivalent to a 6.4-kg [14-lb] crib (18). In that same study, when two 1.8 by 2.4-m [4 by 8-ft] panels of the specimen material formed one corner of a 3.0 by 3.0-m [10 by 10-ft] experimental room, the 6.4-kg crib located in the same corner was able to cause flashover with plywood and particle board but not with the wood fiber insulating board. A report by Quintiere and McCaffrey (26) illustrates the effect of various cribs and ventilation sizes on fire intensity.

6.4.2.10 Relatively large-dimension open corner room configurations, consisting of one long wall, one short or end wall, and an included horizontally oriented ceiling, have been standardized and codified as proprietary test methods by Underwriters' Laboratories and by Factory Mutual Research Corporation (UL 1040 and FM 4880).

6.4.3 *Location*—The location of the ignition source is one of the most important considerations when conducting compartment experiments. Fig. 2 shows schematically how the flame height from a given ignition source increases when placed against a wall and in the corner. Also, the flame height is strongly dependent on the proximity of the ignition source to each wall. The distance from the wall might be set at 25 or 50 mm [1 or 2 in.]. See Babrauskas (27) and Thomas, et al. (28) for more detail.

6.4.3.1 The simplest model of combustion of an ignition source is given by Lie (29), wherein he notes that, although the combustion process is determined by a large number of parameters, all of these parameters are related to the three essential elements of fuel, heat, and air. The estimated height of flames has been the subject of many studies (30-33), but in general it can be simplified to a relationship in which flame height is governed by the entrainment of air into the flame plume. If the access of air to the flame is blocked from one side, such as would occur by placing the ignition source against a wall, then one would expect a higher flame for the same rate of gaseous fuel leaving the source. This analogy can be extended further to an ignition source in a corner in which the two walls block air access from two sides. This gives the longest flame extension compared to either the free-burning source or that against a wall. Because of this result, the normal practice is to make the corner the standard location for the ignition source for the room fire experiments when the lining material is intended to become involved first. The ignition source should be placed directly in contact with an item of furnishing if that is to be involved first. In the case of a liquid fuel ignition source, it may be desirable to pour the fuel directly onto the item of furnishing.

6.4.3.2 The imposition of a ceiling on the flame plume of an ignition source has a very special effect on the combustion of the fuel. Entrainment of ambient air into the fire plume is decreased sharply when the plume turns the corner and becomes a ceiling jet. Such decreased entrainment leads to an increase in flame lengths since more flame surface is necessary to consume the fuel vapor delivered by the plume. This special

feature of ceiling jets has been discussed by Alpert (34, 35). The net result of the interaction of the flame plume and the ceiling is shown schematically in Fig. 3, in which the flame plume is represented as having a height L_2 above the ceiling, but spreading a distance L_1 under a ceiling. It has been noted by P. H. Thomas that the ratio of L_1 to L_2 may be as large as 6 or 7:1, but this does not appear to have been measured systematically for a range of fuels, ceiling materials, and boundary configurations. In any event, the use of ignition sources that produce flame heights substantially higher than the compartment ceiling may lead to flash-over and sustained involvement with only minimal combustion of the specimen material.

6.4.4 *Burning Characteristics*—A description should be given of calibration experiments performed with linings that do not contribute significantly to a fire. These experiments are conducted with the same ignition source, and the following parameters should be recorded as a function of time: ceiling temperatures, mass loss rate, heat flux as a function of distance, and observed flame height.

6.5 *Instrumentation:*

6.5.1 *Calibration:*

6.5.1.1 All instruments used should be calibrated carefully prior to testing, with standard sources, if possible using traceable sources or laboratories. The instruments in question include load cells or weighing platforms, heat flux gages or radiometers, smoke meters, flow or velocity transducers, gas burners, and gas composition analyzers. Some examples of calibration techniques include the following: (a) small, portable wind tunnels have been used successfully to calibrate anemometers, (b) a comparative technique was developed by NIST in 2001 (36) for calibrating the wide-angle type heat flux transducers (or total heat flux gages) commonly used in room fire tests, (c) a different technique was developed at the Swedish National Research and Testing Institute (37) for the same application, and (d) a portable black body has been found suitable for calibrating narrow-angle heat flux transducers (which are less commonly used in room fire tests).

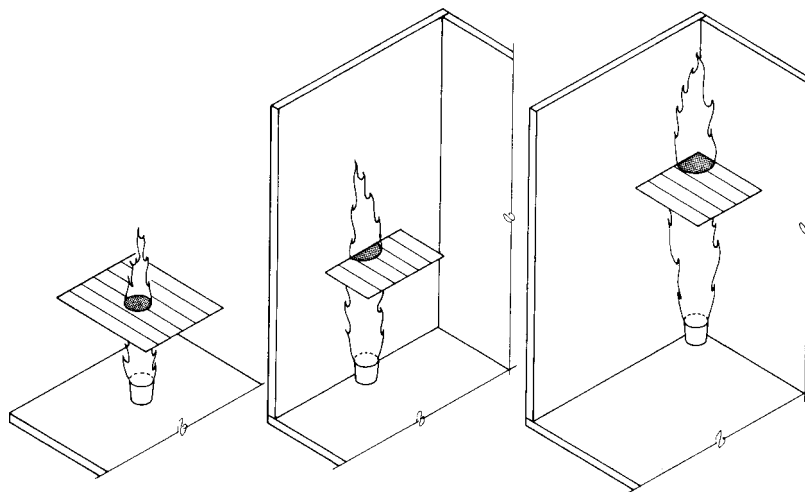

(a) In the center of the test area (b) At one wall (c) At the corner
FIG. 2 Schematic Diagrams of Ignition Sources (Note the change of flame height shown)

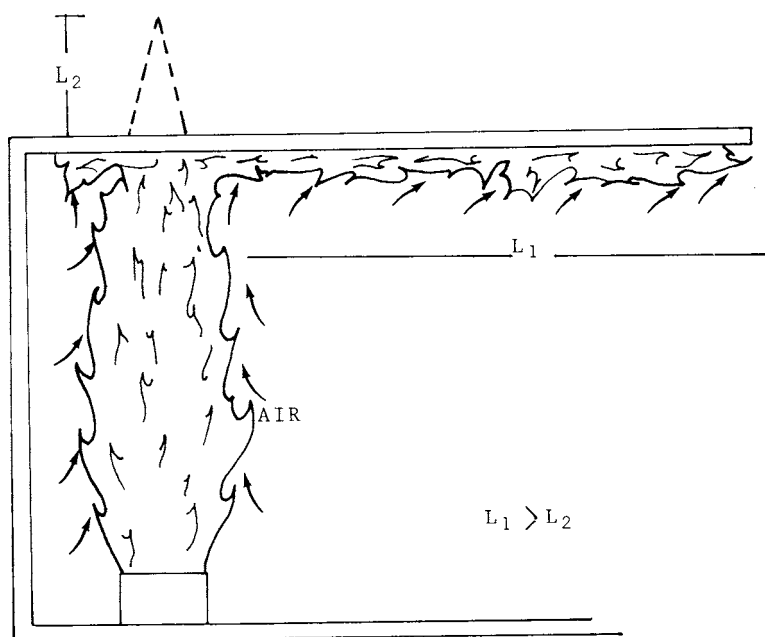

FIG. 3 Flame Plume Under a Ceiling

6.5.1.2 Even if all the instrumentation has been calibrated, there are still some potential issues that operators should be looking into during testing. For example, operators should be aware of potential changes in the response of an instrument due to soot accumulation during the test. Thus, reliability checks using sources of known outputs of heat (or of any other fire property) are useful tools.

6.5.1.3 It is important to report uncertainty and accuracy of all measured values. There are methods that are being developed to assess uncertainty (such as those discussed in ISO 17025 and the ISO GUM guide) and accuracy (several test method standards include information on precision and accuracy of the corresponding test method) and as much information as possible should be reported.

6.5.2 *Heat Release Rate*—It is usually extremely important in a room-scale test to know the heat release rate of the fire throughout the experiment. Load cell or platform transducers can be used to determine the mass-time history of the primary burning specimen, and that is always useful information. However, mass loss rate measurements cannot be converted directly to heat release rates due to the unknown heat of combustion of the volatiles (particularly if the fuel is not homogeneous) and the unknown completeness of the combustion reaction. Heat release rates are typically determined by continuous measurement of oxygen consumption in the exhaust duct throughout the test and calculation of the heat release rate by using the oxygen consumption principle (38). This requires the installation of a hood and an exhaust duct for collecting all of the combustion products leaving the fire room. Required duct measurements for the calculations are: the oxygen concentration, the differential pressure, and the gas temperature at the orifice plate or velocity probe (the latter ones are needed to determine mass flow rate in the duct, see Practice E2067). Increased accuracy of heat release measurements is obtained if carbon monoxide, carbon dioxide, and water are

also measured in the exhaust duct. All exhaust duct measurements should be made at a location at which the stream is well mixed (turbulent flow). This will occur at distances, downstream of the exhaust duct, of no less than 6 duct diameters (see 6.6). The gas concentrations, along with the mass flow rate in the duct, can be used to calculate the heat release rate as described in Ref (38). Further details can be found in the corresponding test methods and in a textbook addressing the subject of heat release in fires (39).

6.5.3 Heat Flux:

6.5.3.1 While knowing the total energy output of the fire is useful for evaluating a product's performance, determining the distribution of energy flux within the compartment is necessary in order to explain how fire spread occurs. The heat flux gages used in room fire tests should measure the total flux over a 2π solid angle. Water-cooled Gardon-type and Schmidt-Boelter-type gages with black receiving surfaces are by far the most reliable and accurate of all flux transducers. With this type of gage, the flux incident on a surface from all sources can be measured. Reradiative or convective heat transfer from a surface near the gage can be estimated from surface temperature measurements. Thus the calculation of the net flux to the surface is allowed. Caution must be exercised, when using Gardon-type gages, to make measurements with a large convective fraction as a result of calibration constant changes. Additional information is contained in the literature (40-42). One of the parameters used as an indicator of flashover in a room is a heat flux of 20 kW/m^2 at the floor in the standard ASTM room (2.4 by 3.7 by 2.4 m high, or 8 by 12 by 8 ft high) (see for example NFPA 286 or NFPA 555).

6.5.3.2 The importance of frequent cleaning, blackening, and recalibration should be stressed. The buildup of deposits on the foil of the Gardon gage will reduce sensitivity, and, unfortunately, this can occur during an experiment. The Schmidt-Boelter gage is less affected by deposits, generally