

22

INTERNATIONAL STANDARD

ISO 2974

Second edition
1989-09-15



Road vehicles — High-pressure fuel injection pipe end-connections with 60° female cone

*Véhicules routiers — Raccords à cône femelle de 60° pour lignes d'injection à haute
pression*



Reference number
ISO 2974 : 1989 (E)

Foreword

ISO (the International Organization for Standardization) is a worldwide federation of national standards bodies (ISO member bodies). The work of preparing International Standards is normally carried out through ISO technical committees. Each member body interested in a subject for which a technical committee has been established has the right to be represented on that committee. International organizations, governmental and non-governmental, in liaison with ISO, also take part in the work. ISO collaborates closely with the International Electrotechnical Commission (IEC) on all matters of electrotechnical standardization.

Draft International Standards adopted by the technical committees are circulated to the member bodies for approval before their acceptance as International Standards by the ISO Council. They are approved in accordance with ISO procedures requiring at least 75 % approval by the member bodies voting.

International Standard ISO 2974 was prepared by Technical Committee ISO/TC 22, *Road vehicles*.

This second edition cancels and replaces the first edition (ISO 2974 : 1974), of which it constitutes a technical revision.

© ISO 1989

All rights reserved. No part of this publication may be reproduced or utilized in any form or by any means, electronic or mechanical, including photocopying and microfilm, without permission in writing from the publisher.

International Organization for Standardization
Case postale 56 • CH-1211 Genève 20 • Switzerland

Printed in Switzerland

Road vehicles — High-pressure fuel injection pipe end-connections with 60° female cone

1 Scope

This International Standard specifies the dimensional requirements of high-pressure pipe connections for compression-ignition (diesel) engine fuel injection equipment.

It applies to 60° female cones with external threaded connectors types 1 and 2 (see figures 1, 2 and 3), and to the male cone type end and the internal threaded tube nuts assembly (see figure 4) of high-pressure pipe connections for tubes with diameters up to 12 mm inclusive.

2 Normative references

The following standards contain provisions which, through reference in this text, constitute provisions of this International Standard. At the time of publication, the editions indicated were valid. All standards are subject to revision, and parties to agreements based on this International Standard are encouraged to investigate the possibility of applying the most recent editions of the standards indicated below. Members of IEC and ISO maintain registers of currently valid International Standards.

ISO 261 : 1973, *ISO general purpose metric screw threads — General plan.*

ISO 3508 : 1976, *Thread run-outs for fasteners with thread in accordance with ISO 261 and ISO 262.*

3 Requirements

3.1 Dimensions and tolerances

Figures 1 and 2 indicate the basic requirements for the connector at the fuel injector and fuel injection pump to allow interchangeability for high-pressure fuel injection pipe assemblies.

The 60° female cone and its relationship to the external thread of the connector shall meet the requirements of figure 1: variations at the smaller end of the female cone as shown in figure 3 are acceptable.

Dimensions and tolerances are given in table 1. Details not specified are left to the manufacturer's choice.

With reference to dimension T in figures 1 and 2, the external thread may be made optionally to type 1 or 2. However it shall be possible to screw the GO-gauge for the thread up to the plane specified by dimension T for both types.

Figure 4 identifies the pipe end assembly dimensions which are important to sealing, normally on the leading edge of the cone on the high-pressure fuel injection pipe (see also 3.2).

3.2 Materials

The specification of material and heat treatment shall be chosen according to the use intended.

To ensure that deformation takes place at the sealing face of the tube and cone, when sealing, the material of the cone shall be softer than the material of the external threaded connector.

4 Designation

An end-connection in accordance with this International Standard shall be designated by the following elements, in the order given:

- a) reference to this International Standard;
- b) the shape in accordance with figure 3;
- c) the tube outside diameter, in millimetres;
- d) the thread designation, in accordance with ISO 261.

EXAMPLE

An end connection of shape A, of tube outside diameter 10 mm, with an M22 × 1,5 thread is designated:

ISO 2974 - A 10 - M22 × 1,5

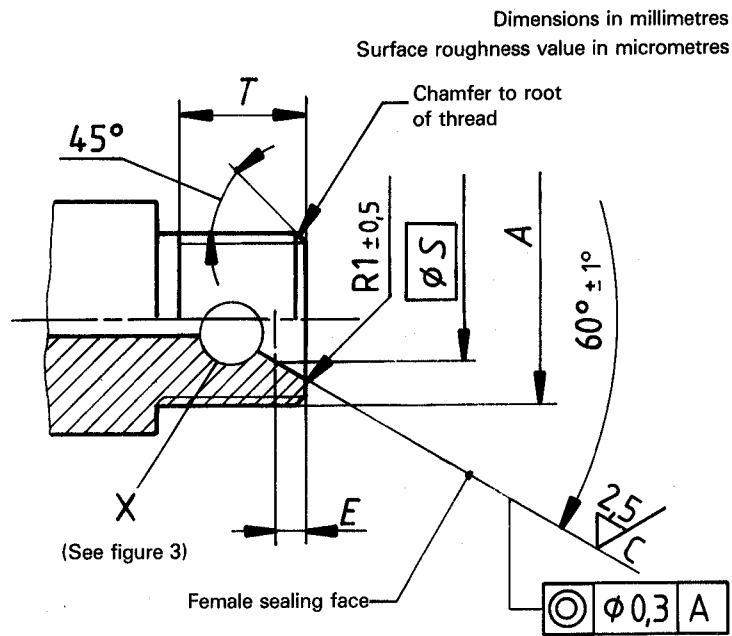
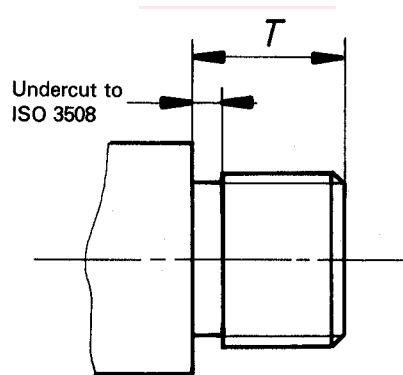

Figure 1 — External threaded connector — Type 1



NOTE — All other dimensions and specifications as for type 1.

Figure 2 — External threaded connector — Type 2

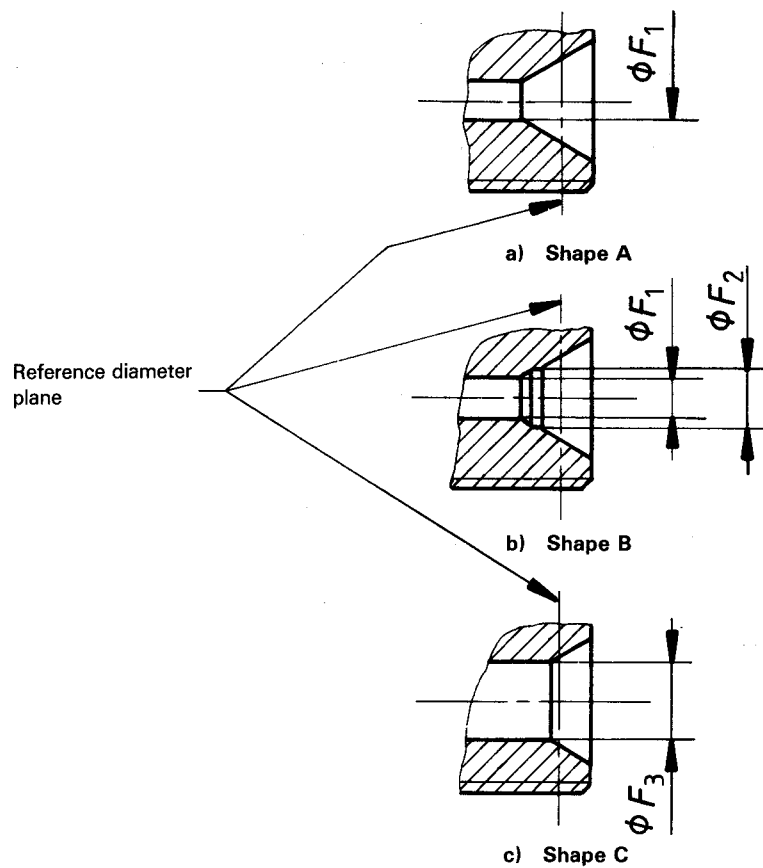
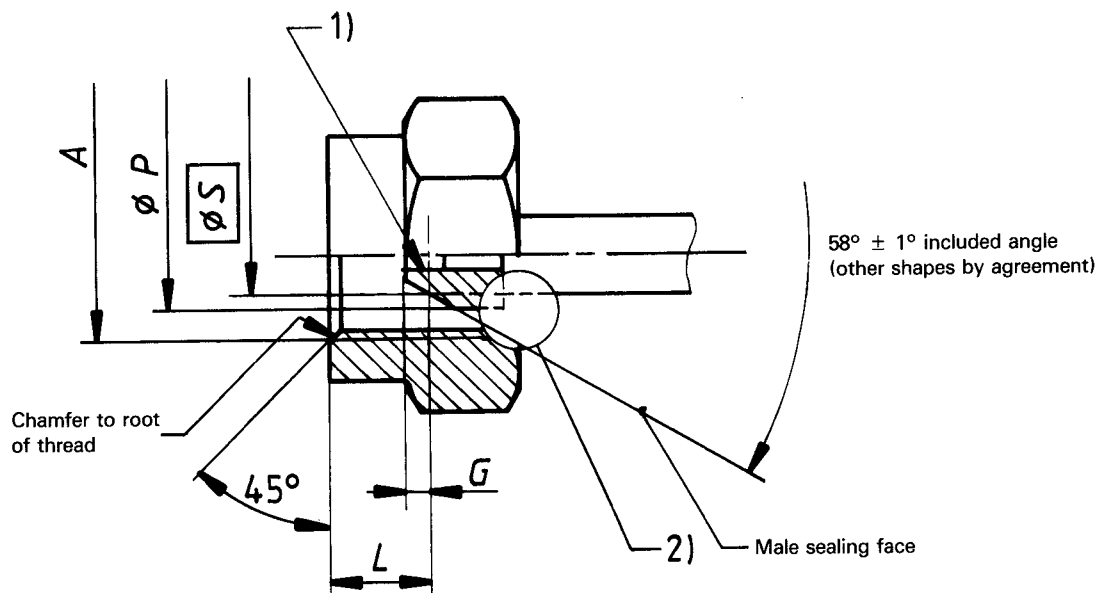

Figure 3 — Shapes of detail X on external threaded connectors, types 1 and 2



- 1) The tube end bore entrance configuration shall be so chosen that, after final assembly, the inside diameter of the tube is not reduced.
- 2) Design of the sealing cone shoulder and the cap nut shall be agreed between customer and manufacturer.

Figure 4 — Nut and tube end assembly

Table 1

Dimensions in millimetres

Tube outside diameter	Thread ¹⁾ <i>A</i>	Reference diameter, <i>S</i>	<i>F</i> ₁ ²⁾ ± 0,1	<i>F</i> ₂ + 0,3 0	<i>F</i> ₃ ²⁾ max.	<i>E</i> + 0,3 0	<i>P</i> ± 0,5	<i>G</i> + 0,5 0	<i>L</i> max.	<i>T</i> min.
5	M10 × 1,25 M12 × 1,5	5,5	1,25 to 2,5	2,5		0,8	7,5	0,5	7	10
6	M12 × 1,5 M14 × 1,5	6,5	1,5 to 3	5	6,1	0,8	9	0,8	8	11
8	M16 × 1,5 M18 × 1,5 M22 × 1,5	8,5	2 to 4	4	7,3	2,6	11,5	0,9	11	16,5
10	M20 × 1,5 M22 × 1,5 M24 × 1,5	10,5	2,5 to 5	5	9,3	2,6	13,5	0,9	12,5	18
12	M22 × 1,5 M26 × 1,5	12,5	3 to 5	5	10,3	2,6	15,5	1,8	15,5	21

1) Tolerance classes of threads: 6g for external threaded connector;
6H for connector nuts.

2) Dimension *F* shall be adapted to the tube inside diameter for the sake of optimum flow conditions. If required, for instance for edge filters, application of dimension *F*₃ is allowed.

iTeh STANDARD PREVIEW
(standards.iteh.ai)

ISO 2974:1989

<https://standards.iteh.ai/catalog/standards/sist/982f08ac-6ff1-48ac-be86-f2ca6cbc9e09/iso-2974-1989>