



Designation: ~~D3419-00 (Reapproved 2006)~~ Designation: D3419 - 12

# Standard Practice for In-Line Screw-Injection Molding Test Specimens From Thermosetting Compounds<sup>1</sup>

This standard is issued under the fixed designation D3419; the number immediately following the designation indicates the year of original adoption or, in the case of revision, the year of last revision. A number in parentheses indicates the year of last reapproval. A superscript epsilon ( $\epsilon$ ) indicates an editorial change since the last revision or reapproval.

## 1. Scope

~~1.1 This practice covers the general principles to be followed when injection molding test specimens of thermosetting materials. It is to be used to obtain uniformity in methods of describing the various steps of the injection molding process and in the reporting of those conditions. The exact molding conditions will vary from material to material, and should become part of the material specification or be agreed upon between the purchaser and the supplier.\*~~

1.1 This practice covers the general principles to be followed when injection molding test specimens of thermosetting materials. It is to be used to obtain uniformity in methods of describing the various steps of the injection molding process and in the reporting of those conditions. The exact molding conditions will vary from material to material, and if not incorporated in the material specification, shall be agreed upon between the purchaser and the supplier or determined by previous experience with the particular type of material being used and its plasticity.

NOTE 1—The utility of this practice has been demonstrated for the molding of thermosetting molding compounds exhibiting lower-viscosity non-Newtonian flow.

1.2 The values stated in SI units are to be regarded as standard. The values given in parentheses are for information only.

1.3 *This standard does not purport to address all of the safety problems, if any, associated with its use. It is the responsibility of the user of this standard to establish appropriate safety and health practices and determine the applicability of regulatory limitations prior to use.*

1.4 This practice assumes the use of reciprocating screw injection molding machines.

NOTE 2—~~This standard is similar in content (but not technically equivalent) to ISO 10724:1994(E).~~ 2—This standard and ISO 10724 address the same subject matter, but differ in technical content.

## 2. Referenced Documents

2.1 *ASTM Standards:*<sup>2</sup>

D883 [Terminology Relating to Plastics](#)

~~D958 Practice for Determining Temperatures of Standard ASTM Molds for Test Specimens of Plastics~~ 3641 Practice for Injection Molding Test Specimens of Thermoplastic Molding and Extrusion Materials

2.2 *ISO Standards:*<sup>3</sup>

~~ISO 10724:10724 :1994(E)—Plastics—Thermosetting Moulding Materials—Injection Moulding of Multipurpose Test Specimens~~

~~ISO 3167:1993, Plastics—Multipurpose Test Specimens~~ ISO 3167 :1993, Plastics—Multipurpose Test Specimens

## 3. Terminology

3.1 *Definitions:*

3.1.1 *General*—Definitions of terms applying to this practice appear in Terminology D883.

3.1.2 *injection molding*—the process of forming a material by forcing it, in a fluid state and under pressure, through a runner system (sprue, runner, and gate(s)) into the cavity of a closed mold.

3.1.3 *Discussion*

<sup>1</sup> This practice is under the jurisdiction of ASTM Committee D20 on Plastics and is the direct responsibility of Subcommittee D20.09 on Specimen Preparation. Current edition approved March 15, 2006. Published March 2006. Originally approved in 1975. Last previous edition approved in 2000 as D3419-00. DOI: 10.1520/D3419-00R06.

Current edition approved April 1, 2012. Published May 2012. Originally approved in 1975. Last previous edition approved in 2006 as D3419 - 00(2006). DOI: 10.1520/D3419-12.

<sup>2</sup> For referenced ASTM standards, visit the ASTM website, [www.astm.org](http://www.astm.org), or contact ASTM Customer Service at [service@astm.org](mailto:service@astm.org). For *Annual Book of ASTM Standards* volume information, refer to the standard's Document Summary page on the ASTM website.

<sup>3</sup> Available from American National Standards Institute (ANSI), 25 W. 43rd St., 4th Floor, New York, NY 10036, <http://www.ansi.org>.

\*A Summary of Changes section appears at the end of this standard.

3.1.2.1 Discussion—Screw-injection molding and reaction-injection molding are types of injection molding.

3.2 Definitions of Terms Specific to This Standard:

3.2.1 breathing, *v*—the operation of opening a mold or press for a very short period of time at an early stage in the process of cure.

3.2.2 Discussion

3.2.1.1 Discussion—Breathing allows the escape of gas or vapor from the molding material and reduces the tendency of thick moldings to blister.

3.2.3

3.2.2 cavity (of a mold), *n*—the space within a mold to be filled to form the molded product.

3.2.4

3.2.3 landing (of a cavity), *v*—the practice of relieving the mold around the cavity (cavities), thus reducing the surface area of the flat mating surfaces of the mold halves.

3.2.3.1 Discussion—Typical lands are 4.5 mm (3/16 in.) to 6 mm (1/4 in.) in width. Landing pads should It is recommended that landing pads be incorporated to hold the mold open 0.0125 mm (0.0005 in.) to prevent damage to the lands.

#### 4. Significance and Use

4.1 This practice is subject to the definition of injection molding given in 3.1.2 with the further provision that with in-line screw injection the plastic compound, heated in a chamber by conduction and friction, is fluxed by the action of a reciprocating screw and then is forced into a hot mold where it solidifies. Hereafter, in-line screw-injection molding will be referred to simply as injection molding.

4.2 The mold referenced in this section (see Fig. 1) is generally useful, and describes what have been the most common specimens required for the testing of thermosets. ISO specimens and testing are gaining favor, however. Practice D3641 and ISO 10724 describes describe the layout and practice for injection molding the multi-purpose specimens in accordance with ISO 3167-ISO 3167.

4.3 Typically, injection-molded test specimens are made with shorter cycles than those used for similar moldings made by compression, and the cycle is equal to or faster than that for transfer molding.

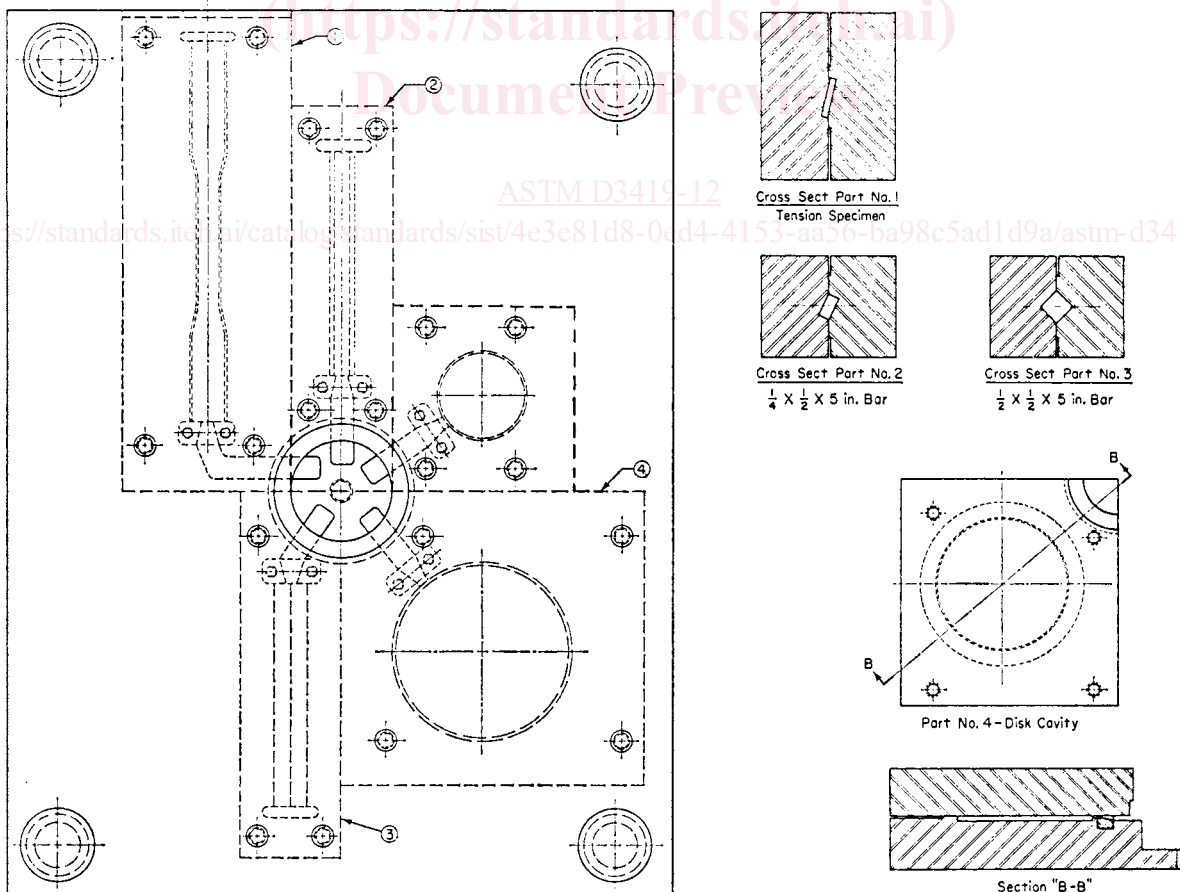

NOTE 1—Thermometer wells shall be 8 mm (5/16 in.) in diameter to permit use of a readily available thermometer.

FIG. 1 Five-Cavity Transfer Mold for Thermosetting Plastic Test Specimens (Steam Cores Not Shown)

4.4 Breathing of the mold is not usually required to release trapped volatile material as the gas is free to flow from the vent end of the mold. This is particularly advantageous for heat-resistant compounds and reduces the tendency for molded specimens to blister at high exposure temperatures.

4.5 Injection molding is intended for low-viscosity compounds. One set of processing parameters cannot be specified for all types of thermosetting materials, nor for samples of the same material having different plasticities.

4.6 Materials containing fibrous fillers such as glass roving, chopped cloth, or cellulosic fibers can be injection molded, but their properties will be affected depending upon how much fiber breakdown occurs as the compound is worked by the screw and as it passes through the system of runners and gates. The orientation of the fibers in the molded specimen will also affect injection-molded properties.

4.7 Flow and knit lines in a molded piece are often sites of mechanical or electrical weakness. The fluxed material passing through the gate wrinkles and folds as it proceeds into the mold cavity. Knit lines ~~may be~~ are found to some degree throughout the molded piece; ~~these knit lines and can affect end-test results.~~ Fibers and other reinforcements in the molding compound align with the flow pattern and, ~~consequently, may be~~ generally, are perpendicular to the axis of the bar at its center and parallel at its surface.

4.7.1 Placement and size of gates and vents can be used to minimize flow and knit lines, for example, side gating of bars will minimize the tendency of the material to fold onto itself as the material front proceeds through the length of the mold.

4.8 The Izod impact strength of injection-molded specimens containing short fibers will generally be lower than the values obtained using compression molding methods. The impact strength ~~may~~ can also vary along the axis of the bar due to molding parameters, flow patterns, and fiber orientation.

4.9 The flexural and tensile strength of injection-molded specimens of molding compounds containing short fibers will generally be higher than the values obtained using compression-molding methods. Flexural tests are particularly sensitive to injection molding due to the thin resin skin formed at the surface of the bar during final filling of the cavity and pressure buildup.

4.10 At constant mold temperature the following parameters ~~may~~ are known to cause an underfilled condition at the vented end of the cavity: incorrect plasticity, too low an injection pressure, insufficient material, too long an injection time, blocked vents, high stock temperature, or incorrect die temperature.

## 5. Apparatus

5.1 *In-Line, Screw-Injection Machine*— A device incorporating a hydraulically or electrically driven screw which, working against a predetermined back pressure, draws material from the feed hopper and by frictional and conducted heat works a charge of material into a hot plastic state. Following the plasticating step, the screw stops rotating, moves forward and forces the hot material through the nozzle, sprue, runner, and gate into the cavity. ~~The machine should be capable of accurately delivering and maintaining suitable~~ Optimal injection and clamp pressures are within the range ~~from~~ of 70 to 140 MPa (10,000 to 20,000 psi). Measurement of actual molding pressures can be made with pressure transducers placed strategically in the cavities.

5.1.1 The clamp force of the machine shall be sufficient to prevent excessive flashing under all operating conditions (see 5.2.5).

5.2 *Mold*—The mold cavities and layout ~~will~~ depend on the specimens required by the tests in question. The mold layout shown in Fig. 1 has been found satisfactory, although molds with fewer cavities, or different configurations, or both may can be used. Molds with multiple-identical-cavity layouts with symmetrical gates and runners are ~~normally~~ recommended. Single cavity molds are not recommended. In ~~either~~ any case, it is important to describe the mold in the report on the specimen preparation.

5.2.1 Family molds like the one shown in Fig. 1 require proper precautions to ensure that constant and uniform filling is achieved in all cavities.

5.2.2 Gate dimensions equal to two-thirds of the width and height of end-gated specimens are recommended for specimens not greater than 4-mm (0.16-in.) thickness. For specimens over 4-mm (0.16-in.) thickness, or for other than end-gated specimens, gate dimensions of 8-mm (0.31-in.) width by 3-mm (0.12-in.) thickness are recommended. ~~The gates should be as short as possible, Short gate lengths, not exceeding 3 mm (0.12 in.) in length, are recommended.~~

5.2.3 Suitable venting must be provided from each cavity. Dimensions of 4 to 6-mm (0.16 to 0.24-in.) width by 0.05 to 1-mm (0.002 to 0.004-in.) depth are recommended.

5.2.4 It is recommended that cavities be landed, so that if flashing does occur, the mold will re-close after the injection stroke. Typical lands are 4.5 mm ( $\frac{3}{16}$  in.) to 6 mm ( $\frac{1}{4}$  in.) in width. Landing pads ~~should be incorporated~~ are recommended to hold the mold open 0.0125 mm (0.0005 in.) in order to prevent damage to the lands.

5.2.5 Full round runners, at least 6-mm (0.24-in.) diameter, are recommended as they offer less resistance to flow.

5.2.6 Sharp corners in gates and runners are to be avoided as they can cause hot spots and premature curing.

5.2.7 On larger specimens, such as discs or plaques, multiple gates can produce knit lines where the material flows together. One larger gate is generally better than several smaller gates.

5.2.8 Mold surfaces ~~should be~~ finished to a roughness of 0.4 to 0.8  $\mu\text{m}$  (SPI-SPE #2 or equivalent<sup>4</sup>) are preferred, unless it is known that the particular test is not affected by a coarser surface finish. Chrome plating is recommended but not necessary. All Draw polishing of all cavity surfaces should be draw polished to in the direction of flow will facilitate specimen removal.

<sup>4</sup> Mold comparison kits are available from the D-M-E Co., 29111 Stephenson Highway, Madison Heights, MI 48071.