



Designation: ~~E2194-09~~ Designation: E2194 - 12

Standard Practice for Multiangle Color Measurement of Metal Flake Pigmented Materials¹

This standard is issued under the fixed designation E2194; the number immediately following the designation indicates the year of original adoption or, in the case of revision, the year of last revision. A number in parentheses indicates the year of last reapproval. A superscript epsilon (ϵ) indicates an editorial change since the last revision or reapproval.

INTRODUCTION

Surfaces that exhibit different colors depending on the angles of illumination or sensing are said to be “gonioapparent.” Colorimetric values of reflecting gonioapparent materials are derived from spectrometric (narrow band) or colorimetric (broad band) measurements of reflectance factor, at various aspecular angles. When using spectral values, tristimulus values are computed using the CIE Standard Observer and the spectrum of the illuminant, as described in Practice E308. This practice, E2194, specifies the measurement of color observed at various aspecular angles.

1. Scope

1.1 This practice covers the instrumental requirements, standardization procedures, material standards, and parameters needed to make precise instrumental measurements of the colors of gonioapparent materials. This practice is designed to encompass gonioapparent materials; such as, automotive coatings, paints, plastics, and inks.

1.2 This practice addresses measurement of materials containing metal flake and pigments. The measurement of materials containing metal flakes requires three angles of measurement to characterize the colors of the specimen. The optical characteristics of materials containing pearlescent and interference materials are not covered by this practice.

NOTE 1—Data taken by utilizing this practice are for gonio-appearance quality control purposes. This procedure may not necessarily supply appropriate data for spatial-appearance or pigment identification.

1.3

1.3 The values stated in SI units are to be regarded as standard. The values given in parentheses are for information only.

1.4 This standard does not purport to address all of the safety concerns, if any, associated with its use. It is the responsibility of the user of this standard to establish appropriate safety and health practices and determine the applicability of regulatory limitations prior to use.

2. Referenced Documents

2.1 ASTM Standards:²

E284 Terminology of Appearance

E308 Practice for Computing the Colors of Objects by Using the CIE System

E805 Practice for Identification of Instrumental Methods of Color or Color-Difference Measurement of Materials

E1345 Practice for Reducing the Effect of Variability of Color Measurement by Use of Multiple Measurements

E1708 Practice for Electronic Interchange of Color and Appearance Data

E2539 Practice for Multiangle Color Measurement of Interference Pigments

2.2 CIE Document:³

Publication No. 15:2004 Colorimetry

2.3 NIST (NBS) Publication:⁴

LC-1017 Standards for Checking the Calibration of Spectrophotometers

¹ This practice is under the jurisdiction of ASTM Committee E12 on Color and Appearance and is the direct responsibility of Subcommittee E12.12 on Gonioapparent Color.

Current edition approved June April 1, 2009; 2012. Published June 2009; May 2012. Originally approved in 2003. Last previous edition approved in 2003; 2009 as E2194 - 03 ϵ . DOI: ~~10.1520/E2194-09~~ 10.1520/E2194-12.

² For referenced ASTM standards, visit the ASTM website, www.astm.org, or contact ASTM Customer Service at service@astm.org. For Annual Book of ASTM Standards volume information, refer to the standard's Document Summary page on the ASTM website.

³ Available from U.S. National Committee of the CIE (International Commission on Illumination), http://www.cie.co.at/index_i.e.html.

⁴ Available from National Institute of Standards and Technology (NIST), 100 Bureau Dr., Stop 1070, Gaithersburg, MD 20899-1070, <http://www.nist.gov>.

2.4 *ISO Publication:*⁵

ISO International Vocabulary of Basic and General Terms in Metrology (VIM)

3. Terminology

3.1 Terms and definitions in Terminology E284 are applicable to this practice. See Section “Specialized Terminology on Gonioapparent Phenomena.”

3.2 *Definitions:*

3.2.1 Usually the term metallic refers to a metal material. However, this standard employs the alternative definition given in Terminology E284 as:

3.2.2 *metallic, adj*—pertaining to the appearance of a gonioapparent material containing metal flakes.

3.3 Definitions of metrology terms in ISO International Vocabulary of Basic and General Terms in Metrology (VIM) are applicable to this practice.

4. Summary of Practice

4.1 This practice describes the procedures for the spectrometric and colorimetric measurement of metal flake pigmented materials. The results are reported in terms of CIE tristimulus values and other color coordinate systems. Standardization of the instrument used to measure these materials is defined. Guidelines are given for the selection of specimens and a measurement protocol given. Characterization of these materials requires measurement at a near-specular angle, a mid-specular angle and a far-specular angle. These preferred aspect angles are 15°, 45°, and 110°.

5. Significance and Use

5.1 *Instrumental Measurement Angles*—This practice is designed to provide color data at specific measurement angles that can be utilized for quality control, color matching, and formulating in the characterization of metal flake pigmented materials.

5.2 *Materials*—This practice provides meaningful color information for metal flake pigmented materials. This practice has been tested and verified on paint and coatings, and the same principles should apply to plastics containing metallic flake. For materials containing pearlescent materials refer to Practice E2539.

5.3 *Utilization*—This practice is appropriate for measurement and characterization of metal flake pigmented materials. These data may be used for quality control, incoming inspection, or color correction purposes.

5.4 *Specimen Requirements*—Even though a pair of specimens have the same color values at three angles, if there are differences in gloss, orange peel, texture, or flake orientation, they may not be a visual match.

NOTE 2—Information presented in this practice is based upon data taken on metallic materials coatings. Applicability of this practice to other materials should be confirmed by the user.

6. Apparatus

6.1 *Instrument*—This practice requires measurement at multiple aspect angles, usually accomplished by the use of a multiangle spectrometer as specified in this practice to characterize metal flake pigmented materials. Measurement with a single geometry cannot characterize the gonioappearance of these materials.

6.2 *Standardization*—A standardization plaque with assigned spectral reflectance factor or tristimulus values traceable to a national standardizing laboratory for each specified aspect angle is required to standardize the instrument. The instrument manufacturer typically assigns the values to this plaque.

7. Geometric Conditions

7.1 *Conventional Color Measurement*—In general purpose colorimetry, the common geometry involves illuminating at 45° and sensing at 0°. This geometry is designated 45:0 (45/0). Reverse geometry has the illumination at 0° and the sensing at 45°. That is, the illuminator and sensing geometries are interchanged. This reciprocal geometry is designated 0:45 (0/45). Either geometry is used.

7.1.1 A single bi-directional geometry is specified by illumination and sensing angles with respect to the normal of the plane of the specimen. Angles are measured relative to the normal. Angles on the same side of the normal as the illumination beam are written as positive angles; those on the other side are shown as negative, as shown in Fig. 1.

7.2 *Multiangle Uniplanar Measurement*—The color of metallic materials specimens varies with the angle of view. Thus measurements must be taken at more than one aspect angle to characterize the change of color with angle. The measurement geometry for multiangle measurements is specified by aspect angles. The aspect angle is the viewing angle measured from the specular direction, in the illuminator plane unless otherwise specified. The angle is considered positive when measured from the specular direction towards the illuminator axis. Thus, if the specimen is illuminated at 45° to the normal the specular reflection will be at -45° (See Fig. 1). Sensing at 65° from the normal, and on the same side of normal as the illumination, is sensing 110° away from the specular direction; that is an aspect angle of 110°. Thus, the aspect angle is the sum of the anormal

⁵ ISO/IDE/OIML/BIPM, International Vocabulary of Basic and General Terms in Metrology, International Organization for Standardization, Geneva Switzerland, 1984.

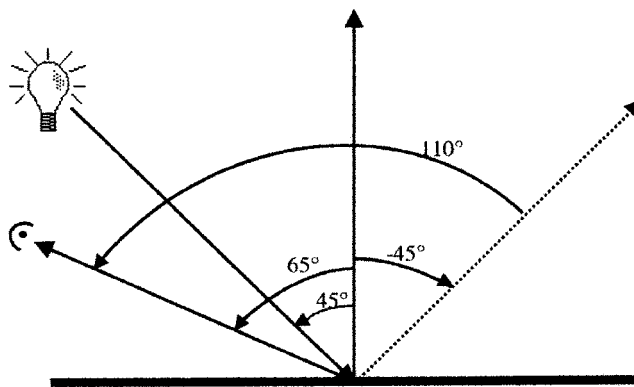

NOTE 1—Anormal illumination angle = 45° and anormal sensing angle = 65°; therefore, aspecular angle = 45 + 65 = 110°.

FIG. 1 Example of Illuminating and Sensing Geometry

illumination and sensing angles. It has been established that for metallic materials or colors, a specific aspecular angle gives the same measurement regardless of angle of illumination.

7.3 *Annular and Circumferential Geometry*—Annular illumination provides incident light to a specimen at all azimuthal angles. This type of illumination minimizes the contribution from directional effects such as the venetian blind effect and surface irregularities. Circumferential illumination is an approximation to annular illumination, incident light being provided from a discrete number of representative azimuthal angles. A large number or an odd number of illumination sources more closely approximates annular illumination. Annular or circumferential illumination minimizes directional effects. Therefore, measurements with annular or circumferential illumination may or may not correlate with how that specimen appears under directional illumination. For example, this system averaging may cause the measured color values of two specimens to be the same or similar, even though these same two specimens would not match visually due to the fact that one specimen exhibits the venetian blind effect.

7.4 *Recommended Geometry*—The instrument shall conform to the following geometric requirements for measurement of reflectance factor unless otherwise agreed upon between the buyer and the seller. The preferred aspecular angles for measurement are 15°, 45°, and 110°.

NOTE 3—Given a geometric configuration, the reverse geometry is considered equivalent, if all other components of the instrument design are equivalent; for example, in the example shown in Fig. 1, the same result would be obtained with the illumination angle at 65° and the sensing angle at 45°. The aspecular angle would still be 110°.

NOTE 4—Measurement angles below are stated in terms of aspecular angles. It has been established that for metallic materials colors, a specific aspecular angle gives the same measurement regardless of angle of illumination. For pearlescent materials, it is known that color is also a function of angle of illumination. The importance of this phenomenon in measurement of pearlescent and interference materials for color difference for quality control or color correction purposes has not been established.

NOTE 5—Uniplanar instruments can measure the venetian blind effect. Circumferential and annular illumination will not quantify this gonioapparent effect.

NOTE 6—There are instruments commercially available with uniplanar, multiangle geometries that give results that characterize gonioapparent materials. These instruments will detect the venetian blind effect and other anomalies. Table 1 delineates the preferred angles. Note that circumferential geometry is limited to <90° aspecular angle. With the variety of instrumentation in common usage, it is incumbent upon the user to determine if an instrument with angles other than the preferred angles is appropriate in their application. Fig. 2

7.4.1 *Near Specular Angle*—The near specular angle used should be as close to the specular direction as possible, without detecting specular light. Surface imperfections can cause light to be reflected in a direction slightly away from the nominal specular direction. Measurement at 15° from the specular minimizes the effects of surface imperfections encountered in most practical industrial specimens. Differences in surface texture may result from spray application differences which can cause flake orientation differences. Measurement at 20° or 25° from specular may be chosen when less sensitivity to application differences between standard and batch is desired. In critical color matching applications, batches should be resampled and resprayed to eliminate

TABLE 1 Preferred Angles

Uniplanar Angle	Preferred Angle
Near specular	15°
Mid-specular angle	45°
Far-specular angle	110°

NOTE 1—Other geometries in common usage are: 25°, 70°, or 75°.

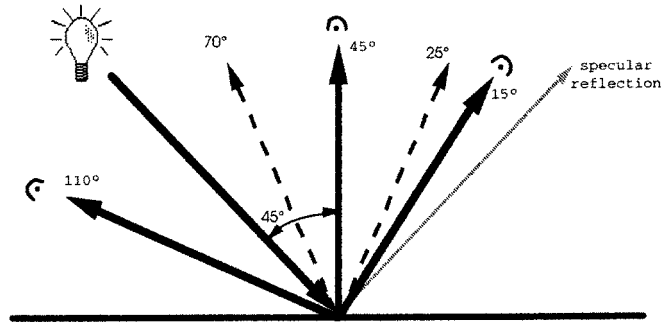

NOTE 1—Solid lines indicate preferred angles.
FIG. 2 Diagram of Aspecular Angles

surface differences and measurements shall be performed at 15°.⁶

7.4.2 *Mid-specular Angle*—The mid-specular color measurement shall be at an aspecular angle of 45° conforming to the geometrical specifications of CIE 15:2004.

7.4.3 *Far-specular Angle*—Visual observation of color differences in a few cases detects sidetone scattering better at angles further away from specular; hence, 110° is the preferred aspecular angle for far-specular measurement. In most but not all cases, angles down to 70° give acceptable results. (**Warning**—Visual assessments of gonioapparent matches typically cover a wide range of aspecular angles, from very near specular, all the way to far-specular angles of 110° or even higher. Therefore, instrumental measurement at far-specular angles below 110° may occasionally result in measurements not agreeing with typical visual assessments. This will occur when specimens are an acceptable visual and instrumental match at angles such as 75° but unacceptable at 110°.)

7.4.4 *Illuminating and Sensing Beam Aperture Angles*—The illuminating beam aperture angle and the sensing beam aperture angle must be less than 8°.

7.4.5 *Tolerances on Measurement Geometries*—Instrumental measurement of specimens entails illumination of a specimen and detection of light reflected at an aspecular angle. Illumination and detection may be collimated or non-collimated. The specimen may be under-illuminated or over-illuminated. The size of the illuminator, detector, and specimen, the distance between them, and uniformity of illumination or detection, will all provide different effective aspecular angles. The following ray tracing procedure must be used to determine the effective aspecular angle and the distribution of the aspecular angles to ensure that the instrument design meets the specifications in Table 2. This ensures equivalent color readings between instruments differing in optical design. Fig. 3 schematically shows a procedure for ray tracing in 2-dimensional space. In actuality, we are dealing with 3-dimensional space and all angles must be calculated in 3-dimensional space relative to the surface normal of the specimen.

7.4.5.1 All rays from the illuminator (I_1 to I_n) to all points on the specimen area (S_1 to S_n) result in mirrored rays in the specular direction (Sp_1 to Sp_n). For each of these specular rays and for each point on the detector area (D_1 to D_n) the aspecular angles have to be calculated. In Fig. 3 the aspecular angles A_{111} , A_{11n} , A_{nn1} , and A_{nnn} are shown. They are all different, as they result from different illumination directions, different points on the specimen, and different points on the active detector area.

7.4.5.2 A minimum of 3000 such rays reaching the detector and their individual aspecular angles must be determined. All rays originating at the illuminator and striking the specimen are to be included. The rays must be distributed evenly over the illuminator and the entire areas of the effective illuminated specimen. The distribution of aspecular angles of all rays reaching the active detector area for each nominal aspecular angle must meet the specifications in Table 2.

7.4.5.3 For example, for the 15° nominal aspecular angle, instrument design must be such that no ray reaching the detector has an aspecular angle less than 7° or more than 23°, and at least 13% of the rays have aspecular angles between 14.5° and 15.5°.

7.4.5.4 In calculation of aspecular angles, one must consider the distance between illuminator, specimen, and receiver as it affects the relative intensity of the rays. In addition, non-uniformities of illumination and detection have to be included as weighting factors on each calculated aspecular angle, so that the effective distribution will be described.

NOTE 7—It will be useful for the user if the manufacturer of the instrument discloses the geometry of the instrument and references the appropriate ASTM standard.

⁶ Rodrigues, Allen, B. J., Measurement of metallic and pearlescent colors, *Die Farbe* 37, pp. 65 -78 (1990).

8. Test Specimen

8.1 Measured values depend on the quality of the test specimens. The specimens must be statistically representative of the lot being tested and should meet the requirements listed below. If the specimens do not meet these requirements, include this information in Section 13.

8.2 *Specimen Handling*—Handle the specimens carefully. Touch them by their edges only. Never lay the measurement surface of the specimen down on another surface or stack specimens without a protective medium as recommended by the provider.

8.3 *Specimen Cleaning*—If necessary, clean the specimens following the providers' cleaning procedure.

8.4 *Specimen Conditioning*—Allow specimens to stabilize in the measurement environment for a period of 4 or more hours before measurement, unless a different time period is agreed to by the parties concerned. Instrument heating may induce the effect of specimen thermochromism.

8.5 *Specimen Physical Requirements* :

8.5.1 The test specimen shall be 8 × 8 cm (approximately 3 × 3 in.) minimum.

NOTE 8—The 7—The recommendation for specimen size corresponds to the physical size required for observation by the CIE 1964 Supplemental Observer (10°). The specimen must subtend >10° when being observed. This observation usually occurs at approximately 45 cm (17.7 in.) from the eye. This specimen size is well suited for instrumental measurement and visual assessment.

8.5.2 The surface of the specimen to be measured should be essentially planar.

8.6 *Specimen Optical Requirements* :

8.6.1 *Uniformity*—Reference specimens and test specimens should be uniform in color and appearance when viewed in a lighting booth. They must be similar in appearance to make meaningful observations. There should be no appearance of mottling or banding in the specimens.

8.6.2 *Gloss*—Specimens should be uniform and similar in gloss when viewed in a lighting booth.

8.6.3 *Surface Texture*—The standard and batch being compared should have substantially similar surface textures. Orange peel is a common example of surface texture.

8.6.4 *Specimen Flake Distribution*—Examine the specimens to ensure that they have similar flake size and distribution. Dissimilar flake distributions will cause results to vary significantly.

8.6.5 *Orientation*—Consistent orientation of the specimen for presentation to the measuring instrument must be controlled for repeatable measurements. This is necessary to minimize errors due to indiscriminate matching of the directionality of the specimen to that of the instrument.

9. Instrument Standardization

9.1 Standardization is essential to ensure that spectrometric or tristimulus measurements with minimum bias are reported. For the measurement of reflectance factor, two standardizations are required, namely,

9.1.1 *Optical Zero (0) Level Standardization*—To verify the optical zero, the instrument manufacturer normally supplies a highly polished black glass or a black trap that has an assigned reflectance factor value.

9.1.2 *Full Scale Standardization*—To standardize the instrument relative to the perfect reflecting diffuser, the instrument manufacturer should provide a standardization plaque with multiangle calibration traceable to a standardizing laboratory.

9.1.3 *Photometric Scale Validation*—To ascertain proper standardization, measure a reference plaque immediately after the standardization sequence and validate that the measured values agree with the assigned values within 0.05 reflectance unit.

9.1.4 *Discussion*—Typically a neutral gray of >50 % reflectance is used for this purpose.

10. Instrumental Performance Verification

10.1 The use of validation standards to verify spectrometric performance of an instrument is recommended. These standards are readily available from multiple sources. The instrument user must assume responsibility for obtaining these standards and their appropriate use. See NIST LC-1017 for further discussion.

10.2 It is recommended that a user measure a durable gonioapparent specimen over time, recording and comparing values to ascertain proper instrument performance.

11. Measurement Procedure

11.1 *Select Measurement Variables*—Select and validate the instrumental configuration before measurement.

11.1.1 Select the desired illuminating and sensing geometries. See Section 6 for definition of angles when measuring gonioapparent materials.

11.1.2 Select the desired observer.

11.1.3 Select the desired illuminant.

11.1.4 Select the desired colorimetric space, for example, CIELAB.

11.2 Variation in measurements of gonioapparent materials is largely due to inherent non-uniformity of these materials. To obtain reproducible results, use large specimen areas that are >490 mm². These results can be achieved by a single measurement with a sampling aperture diameter >25 mm, or by averaging multiple readings taken with a smaller aperture. Refer to Practice E1345 for a description of averaging practice.

11.3 Measure the specimen(s) in accordance with the manufacturer’s instructions.

12. Calculations

12.1 Using spectral data obtained by measuring the specimen, compute the CIE colorimetric values in accordance with the practice specified in Practice E308. Report data using the practices as specified in Practice E805 and Section 13 of this practice.

12.2 *Colorimetric Measured Data*—Output the CIELAB values directly.

13. Report

13.1 It is recommended that the data be submitted for the test report in electronic form (see Practice E1708); however, written data is acceptable.

13.2 The report of the measurement should include the minimum reporting requirements or the recommended reporting requirements. These requirements are presented in ~~Table 3~~ Table 2.

14. Precision and Bias

14.1 The data on repeatability given below are based on one instrument that should be representative of those commercially available.

14.2 *Repeatability*:

14.2.1 Values in ~~Tables 4–6~~ Tables 3–5 listed for White Opal Glass are based on 30 measurements of one white opal-glass specimen typically used to standardize color-measuring instruments. The specimen was not moved during the 30 measurements. The CIELAB color coordinates were calculated using Illuminant D65 and the 1931 Standard 2° Observer. The CIELAB color difference equation was used to determine the color differences from the mean of the 30 measurements.

TABLE 3 2 Reporting Requirements

Function	Required	Recommended
Logistic Data		
Test Operator		✓
Date of Test		✓
Location of Test		✓
Time of Test		✓
Temperature and Relative Humidity		✓
Specimen Description		
Type and Identification		✓
Date of Manufacture		✓
Method of Specimen Preparation		✓
Date of Specimen Preparation		✓
Specimen orientation during measurement	✓	
Any changes that occurred to the specimen as a result of the measurement process	✓	
Any relevant observations by the measurement technician		✓
Instrument Parameters		
Instrument Identification		✓
Instrument Manufacturer		✓
Model Designation	✓	
Serial Number		✓
Instrument Configuration		✓
Observer	✓	
Illuminant	✓	
Color Scale	✓	
Index		✓
Instrument Geometry		✓
Near Specular Angle	✓	
Mid-specular (45:0) Angle	✓	
Far-specular Angle	✓	
Instrument Spectral Parameters		✓
Wavelength Range	✓	
Wavelength Interval	✓	
Spectral Bandpass		✓
Standardization		✓
Full Scale Standardization Plaque		✓
Time and date of last Standardization		✓
Specimen Data		
Spectral Data for each angle of measurement as a function of wavelength. (Note that this is not applicable for spectroradiometers or colorimeters.)		✓
Colorimetric tristimulus data for each designated angle of measurement.	✓	