



Standard Specification for Bell, Cast, Sound Signalling¹

This standard is issued under the fixed designation F956; the number immediately following the designation indicates the year of original adoption or, in the case of revision, the year of last revision. A number in parentheses indicates the year of last reapproval. A superscript epsilon (ϵ) indicates an editorial change since the last revision or reapproval.

1. Scope

1.1 This specification covers cast sound-signalling bells, together with bulkhead mounting plates for the smaller bells, for use on ships, boats, and other marine craft, for compliance with the rules in the convention on the International Regulations for Preventing Collisions at Sea (commonly called Colregs).² See [Appendix X1](#).

1.2 Bells and bulkhead mounting plate shall be sized as indicated in Section 4 (see [Appendix X2](#)).

1.3 For consistency with International Regulations, all measurements are in SI units.

2. Referenced Documents

2.1 *ASTM Standards*:³

[B584 Specification for Copper Alloy Sand Castings for General Applications](#)

2.2 *Other Documents*:²

[CFR 33 Part 81–72 Implementing Rules](#)

[CFR 33 Part 86, Subpart B, Bell or Gong](#)

3. Terminology

3.1 *Definitions*:

3.1.1 *bell, n*—a hollow metal instrument that rings when struck.

3.1.2 *cast, v*—to form by molding in a hollow form for shaping a liquid or plastic substance.

3.1.3 *clapper, n*—hammer like object inside a bell.

4. Classification

4.1 Bells shall be furnished in the following sizes, based on bellmouth diameter in millimetres (see [Appendix X2](#)):

- 4.1.1 150 mm,
- 4.1.2 200 mm (2.2 kg),
- 4.1.3 200 mm (4.5 kg),
- 4.1.4 250 mm,
- 4.1.5 300 mm,
- 4.1.6 360 mm,
- 4.1.7 400 mm, and
- 4.1.8 550 mm.

4.2 Bulkhead mounting plates shall be furnished for the following bell sizes:

- 4.2.1 150 mm, and
- 4.2.2 200 mm.

5. Ordering Information

5.1 Orders for materials under this specification shall include the following information:

- 5.1.1 ASTM designation and year of issue.
- 5.1.2 Number of bells.
- 5.1.3 Size of bell(s) (see [4.1](#)).
- 5.1.4 Additional bulkhead mounting plates (see [4.2](#) and [6.2.2](#)).
- 5.1.5 Inscription required (see [12.1](#)).
- 5.1.6 Packaging, if other than commercial (see [Section 13](#)).

6. Materials and Manufacture

6.1 *Material*:

6.1.1 Bell bodies, clappers, and other cast fittings and parts shall be copper alloy conforming to Specification [B584](#), UNS C87200.

6.1.2 Fittings such as bolts, nuts, washers, pins, and supporting lugs shall be of copper alloy compatible with the bell castings.

6.2 *Manufacture*:

6.2.1 Construction shall be in accordance with [Fig. 1](#), [Fig. 2](#), and [Fig. 3](#).

6.2.2 For [Fig. 1](#) and [Fig. 2](#), one bulkhead mounting plate shall be furnished with each bell, however, additional mounting plates may be ordered.

6.2.3 For all bells, two extra supporting nuts, washers, and acorn nuts (where used) shall be furnished.

¹ This specification is under the jurisdiction of ASTM Committee F25 on Ships and Marine Technology and is the direct responsibility of Subcommittee F25.07 on General Requirements.

Current edition approved May 1, 2012. Published May 2012. Originally approved in 1986. Last previous edition approved in 2006 as F956 – 91 (2006). DOI: 10.1520/F0956-91R12.

² Available from Standardization Documents Order Desk, DODSSP, Bldg. 4, Section D, 700 Robbins Ave., Philadelphia, PA 19111-5098, <http://www.dodssp.daps.mil>.

³ For referenced ASTM standards, visit the ASTM website, www.astm.org, or contact ASTM Customer Service at service@astm.org. For *Annual Book of ASTM Standards* volume information, refer to the standard's Document Summary page on the ASTM website.

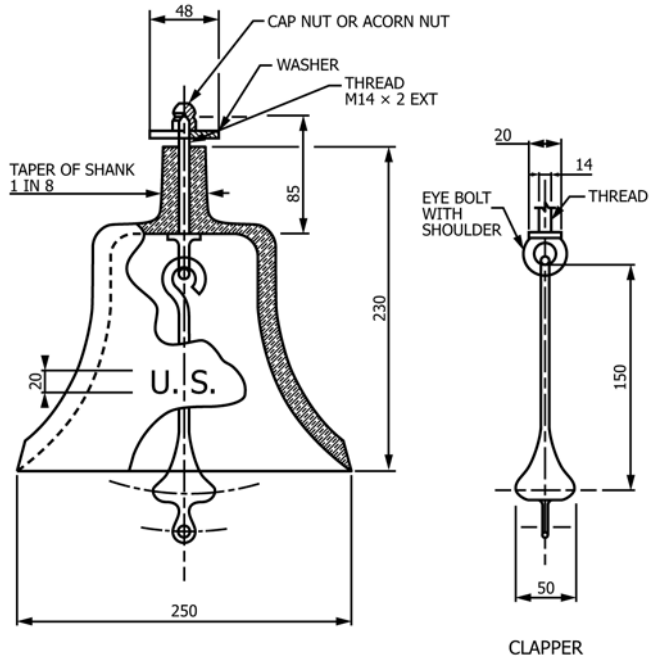
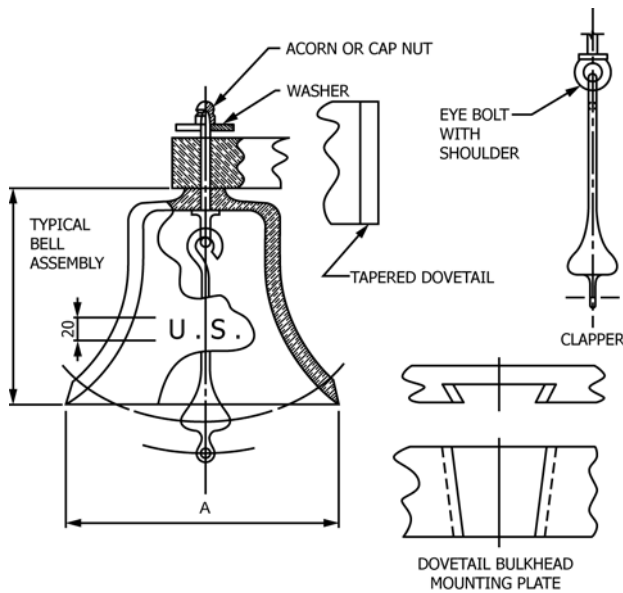

Bell Size, mm	Bell Mass, kg	Dimensions, mm	
		A	B
150	1.4	150	105
200	2.2	200	133
200	4.5	200	152

NOTE 1—All dimensions in millimetres.

Tolerances:

Up to 150 mm: ± 2 mm

Over 150 mm: ± 3 mm

Mass of Bell: ± 0.2 kg (± 0.3 kg for 4.5 kg bell).

Mass of Clapper: No less than 3 % of bell mass.

FIG. 1 Sizes 150 and 200

NOTE 1—All dimensions in millimetres.

Tolerances:

Up to 125 mm: ± 2 mm

Over 125 mm: ± 3 mm

Mass of bell: 9 ± 0.45 kg.

Mass of Clapper: 0.5 ± 0.05 kg.

FIG. 2 Size 250

10.2 For orders for 3 to 10 bells of the same size, 2 bells shall be selected at random. If any one of them fails to meet the requirements, then all bells in the order shall be inspected and tested.

10.3 For orders for more than 10 bells of the same size. They shall be separated into groups of 10 (or fraction thereof) for sampling purposes.

11. Inspection and Testing

11.1 *Responsibility*—Unless otherwise specified in the order, the manufacturer is responsible for the performance of all inspection requirements specified herein. The manufacturer may utilize his own facilities or any commercial facilities acceptable to the purchaser. The purchaser reserves the right to perform any of the inspections set forth in this specification where such inspections are deemed necessary to assure that supplies conform to the prescribed requirements. Nonconforming bells shall not be offered for delivery.

11.2 Inspections:

11.2.1 The dimensions of the bell and appurtenances shall be checked to ensure that they are within the specified tolerances.

11.2.2 The bell, without bracket or mounting plate (for 150 mm and 200 mm light), and clapper shall be weighed separately to ensure that the mass is within the specified tolerance.

11.2.3 For the 150 and 200 light sizes, the brackets shall be engaged and disengaged from each of the mounting plates to ensure portability.

7. Acoustic Requirements

7.1 Bells shall have full, clear, round, and far reaching tones. The sound pressure level shall not be less than 110 dB at a distance of 1 m from it.

8. Dimensions, Mass, and Permissible Variations

8.1 Dimensions and mass of bells, together with tolerances, shall conform to Fig. 1, Fig. 2, and Fig. 3.

9. Workmanship, Finish, and Appearance

9.1 Bells shall be free of cracks, burrs, sharp cutting edges, adhering sand, and other defects and blemishes affecting their life, appearance, and serviceability.

9.2 Bell exteriors and the lower part of the interior, from the bellmouth to 10 mm above the line where the clapper strikes the bell, shall have a smooth polished finish. The “visible” part of the clapper shall have a similar finish.

10. Sampling

10.1 For orders for 1 or 2 bells of the same size, each bell shall be inspected and tested.