**Plastics — Determination of tensile
properties —**

Part 4:

**Test conditions for isotropic and
orthotropic fibre-reinforced plastic
composites**

iTeh STANDARD PREVIEW

(standards.iteh.ai)

Plastiques — Détermination des propriétés en traction —

*Partie 4: Conditions d'essai pour les composites plastiques renforcés
de fibres isotropes et orthotropes*

ISO 527-4:2021

<https://standards.iteh.ai/catalog/standards/sist/c08bf202-523f-49f0-9df7-3a7b7bd241c/iso-527-4-2021>



iTeh STANDARD PREVIEW
(standards.iteh.ai)

[ISO 527-4:2021](https://standards.iteh.ai/catalog/standards/sist/c08bf202-523f-49f0-9df7-3a7b7bd241c/iso-527-4-2021)

<https://standards.iteh.ai/catalog/standards/sist/c08bf202-523f-49f0-9df7-3a7b7bd241c/iso-527-4-2021>



COPYRIGHT PROTECTED DOCUMENT

© ISO 2021

All rights reserved. Unless otherwise specified, or required in the context of its implementation, no part of this publication may be reproduced or utilized otherwise in any form or by any means, electronic or mechanical, including photocopying, or posting on the internet or an intranet, without prior written permission. Permission can be requested from either ISO at the address below or ISO's member body in the country of the requester.

ISO copyright office
CP 401 • Ch. de Blandonnet 8
CH-1214 Vernier, Geneva
Phone: +41 22 749 01 11
Email: copyright@iso.org
Website: www.iso.org

Published in Switzerland

Contents

| | Page |
|---|-----------|
| Foreword..... | iv |
| Introduction..... | v |
| 1 Scope..... | 1 |
| 2 Normative references..... | 1 |
| 3 Terms and definitions..... | 1 |
| 4 Principle..... | 5 |
| 5 Apparatus..... | 5 |
| 6 Test specimens..... | 5 |
| 6.1 Shape and dimensions..... | 5 |
| 6.2 Preparation of specimens..... | 9 |
| 6.2.1 General..... | 9 |
| 6.2.2 End tabs for type 3 specimens..... | 9 |
| 6.2.3 Applications of end tabs for type 3 specimens..... | 9 |
| 6.3 Gauge marks..... | 9 |
| 6.4 Checking the specimens..... | 10 |
| 6.5 Anisotropy..... | 10 |
| 7 Number of specimens..... | 10 |
| 8 Conditioning..... | 10 |
| 9 Procedure..... | 10 |
| 9.1 Test atmosphere..... | 10 |
| 9.2 Measurement of specimen dimensions..... | 10 |
| 9.3 Clamping..... | 11 |
| 9.4 Prestresses..... | 11 |
| 9.5 Setting of extensometers and strain gauges and placing of gauge marks..... | 11 |
| 9.6 Speed of testing..... | 11 |
| 9.6.1 For type 1B test specimens..... | 11 |
| 9.6.2 For type 2, type 3 and type 4 test specimens..... | 11 |
| 9.7 Recording of data..... | 11 |
| 10 Calculation and expression of results..... | 11 |
| 10.1 Calculation of all properties for parallel sided specimens..... | 11 |
| 10.2 Failure location related calculation of tensile strength for type 4 specimens..... | 12 |
| 11 Precision..... | 12 |
| 12 Test report..... | 12 |
| Annex A (informative) Alignment of specimens..... | 13 |
| Annex B (informative) Testing with tapered tensile specimen geometry without tabs (type 4)..... | 15 |
| Annex C (informative) Unbonded tabs or gripping condition without tabs using fine grip face..... | 18 |
| Annex D (normative) Specimen preparation for type 2 and type 3..... | 21 |
| Annex E (normative) Failure location related calculation of tensile strength for type 4 specimens..... | 23 |
| Bibliography..... | 27 |

Foreword

ISO (the International Organization for Standardization) is a worldwide federation of national standards bodies (ISO member bodies). The work of preparing International Standards is normally carried out through ISO technical committees. Each member body interested in a subject for which a technical committee has been established has the right to be represented on that committee. International organizations, governmental and non-governmental, in liaison with ISO, also take part in the work. ISO collaborates closely with the International Electrotechnical Commission (IEC) on all matters of electrotechnical standardization.

The procedures used to develop this document and those intended for its further maintenance are described in the ISO/IEC Directives, Part 1. In particular, the different approval criteria needed for the different types of ISO documents should be noted. This document was drafted in accordance with the editorial rules of the ISO/IEC Directives, Part 2 (see www.iso.org/directives).

Attention is drawn to the possibility that some of the elements of this document may be the subject of patent rights. ISO shall not be held responsible for identifying any or all such patent rights. Details of any patent rights identified during the development of the document will be in the Introduction and/or on the ISO list of patent declarations received (see www.iso.org/patents).

Any trade name used in this document is information given for the convenience of users and does not constitute an endorsement.

For an explanation of the voluntary nature of standards, the meaning of ISO specific terms and expressions related to conformity assessment, as well as information about ISO's adherence to the World Trade Organization (WTO) principles in the Technical Barriers to Trade (TBT), see www.iso.org/iso/foreword.html.

This document was prepared by Technical Committee ISO/TC 61, *Plastics*, Subcommittee SC 13, *Composites and reinforcement fibres*, in collaboration with the European Committee for Standardization (CEN) Technical Committee CEN/TC 249, *Plastics*, in accordance with the Agreement on technical cooperation between ISO and CEN (Vienna Agreement).

This second edition cancels and replaces the first edition (ISO 527-4:1997), which has been technically revised.

The main changes compared to the previous edition are as follows:

- specimen type 4 (tapered tensile specimen) especially for testing of multidirectional, continuous fibre-reinforced thermoplastic composites has been implemented;
- gripping force or pressure (e.g. via torque or manometer depending on gripping system used) has been adjusted;
- the following new annexes have been added:
 - [Annex C](#) (Unbonded tabs or gripping condition without tabs using fine grip faces),
 - [Annex B](#) (Testing with tapered tensile specimen geometry without tabs), and
 - [Annex E](#) (Failure location related calculation of tensile strength for type 4 specimens).

A list of all parts in the ISO 527 series can be found on the ISO website.

Any feedback or questions on this document should be directed to the user's national standards body. A complete listing of these bodies can be found at www.iso.org/members.html.

This corrected version of ISO 527-4:2021 incorporates the following corrections:

- In [Annex D](#), references to [Figure A.1](#) has been corrected to [Figure D.1](#).

Introduction

This document introduces a new test specimen, type 4, with a tapered geometry for use without end tabs. The geometry has been developed to overcome difficulties with bonding end-tabbed test specimens, especially when testing materials based on a thermoplastic matrix.

Guidance on gripping, including grip face design, is also added.

iTeh STANDARD PREVIEW
(standards.iteh.ai)

[ISO 527-4:2021](https://standards.iteh.ai/catalog/standards/sist/c08bf202-523f-49f0-9df7-3a7b7bd241c/iso-527-4-2021)

<https://standards.iteh.ai/catalog/standards/sist/c08bf202-523f-49f0-9df7-3a7b7bd241c/iso-527-4-2021>

Plastics — Determination of tensile properties —

Part 4:

Test conditions for isotropic and orthotropic fibre-reinforced plastic composites

1 Scope

This document specifies the test conditions for the determination of the tensile properties of isotropic and orthotropic fibre-reinforced plastic composites, based upon the general principles given in ISO 527-1.

NOTE 1 Unidirectional reinforced materials are covered by ISO 527-5.

The methods are used to investigate the tensile behaviour of the test specimens and for determining the tensile strength, tensile modulus, Poisson's ratios and other aspects of the tensile stress-strain relationship under the defined conditions.

The test method is suitable for use with the following materials:

- fibre-reinforced thermosetting and thermoplastic composites incorporating non-unidirectional reinforcements such as mats, woven fabrics, woven rovings, chopped strands, combinations of such reinforcements, hybrids, rovings, short or milled fibres or prepregged materials (prepregs);

NOTE 2 Injection moulded specimens are covered by ISO 527-2.

- combinations of the above with unidirectional reinforcements and multidirectional reinforced materials constructed from unidirectional layers, provided such laminates are symmetrical;

NOTE 3 Materials with completely or mainly unidirectional reinforcements are covered by ISO 527-5.

- finished products made from materials mentioned above.

The reinforcement fibres covered include glass fibres, carbon fibres, aramid fibres and other similar fibres.

2 Normative references

The following documents are referred to in the text in such a way that some or all of their content constitutes requirements of this document. For dated references, only the edition cited applies. For undated references, the latest edition of the referenced document (including any amendments) applies.

ISO 527-1:2019, *Plastics — Determination of tensile properties — Part 1: General principles*

ISO 1268 (all parts), *Fibre-reinforced plastics — Methods of producing test plates*

ISO 2818, *Plastics — Preparation of test specimens by machining*

ISO 16012, *Plastics — Determination of linear dimensions of test specimens*

3 Terms and definitions

For the purposes of this document, the following terms and definitions apply.

ISO 527-4:2021(E)

ISO and IEC maintain terminology databases for use in standardization at the following addresses:

- ISO Online browsing platform: available at <https://www.iso.org/obp>
- IEC Electropedia: available at <https://www.electropedia.org/>

3.1 gauge length

L_0
initial distance between the gauge marks on the central part of the test specimen

Note 1 to entry: It is expressed in millimetres (mm).

Note 2 to entry: The values of the gauge length that are indicated for the specimen types in the different parts of ISO 527 represent the maximum relevant gauge length.

[SOURCE: ISO 527-1:2019, 3.1]

3.2 thickness

h
smaller initial dimension of the rectangular cross-section in the central part of a test specimen

Note 1 to entry: It is expressed in millimetres (mm).

[SOURCE: ISO 527-1:2019, 3.2]

3.3 width

b
larger initial dimension of the rectangular cross-section in the central part of a test specimen

Note 1 to entry: It is expressed in millimetres (mm).

[SOURCE: ISO 527-1:2019, 3.3]

3.4 test speed

v
rate of separation of the gripping jaws

Note 1 to entry: It is expressed in millimetres per minute (mm/min).

[SOURCE: ISO 527-1:2019, 3.5]

3.5 stress

σ
normal force per unit area of the original cross-section within the *gauge length* (3.1)

Note 1 to entry: It is expressed in megapascals (MPa).

Note 2 to entry: In order to differentiate from the true stress related to the actual cross-section of the specimen, this stress is frequently called “engineering stress”.

Note 3 to entry: σ for “1”-direction specimens is defined as σ_1 and for “2”-direction specimens as σ_2 (see 3.9 and Figure 2 for definitions of these directions).

[SOURCE: ISO 527-1:2019, 3.6, modified — Domain “<engineering>” and Note 3 to entry has been added.]

3.5.1 strength

σ_m
maximum stress observed during a tensile test

Note 1 to entry: It is expressed in megapascals (MPa).

[SOURCE: ISO 527-1:2019, 3.6.2]

3.6 strain

ε
increase in length per unit original length of the gauge

Note 1 to entry: It is expressed as a dimensionless ratio, or as a percentage (%).

[SOURCE: ISO 527-1:2019, 3.7]

3.6.1 strain at strength

ε_m
strain at which the *strength* (3.5.1) is reached

Note 1 to entry: It is expressed as a dimensionless ratio, or as a percentage (%).

[SOURCE: ISO 527-1:2019, 3.7.3]

3.7 tensile modulus modulus of elasticity under tension

E_t
slope of the stress/strain curve $\sigma(\varepsilon)$ in the interval between the two strains $\varepsilon_1 = 0,05\%$ and $\varepsilon_2 = 0,25\%$

Note 1 to entry: It is expressed in megapascals (MPa).

Note 2 to entry: It may be calculated either as the chord modulus or as the slope of a linear least-squares regression line in this interval.

Note 3 to entry: This definition does not apply to films.

Note 4 to entry: See [Figure 1](#).

[SOURCE: ISO 527-1:2019, 3.9]

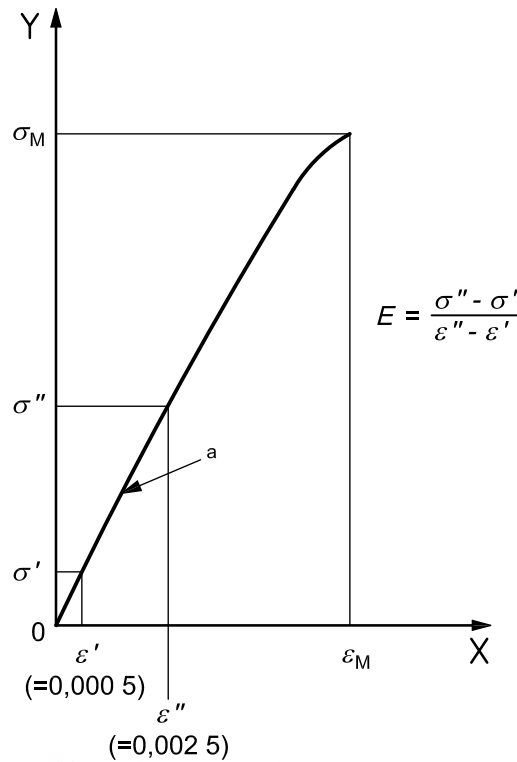

Key

- X strain, ϵ
- Y stress, σ
- a slope E

iTeh STANDARD PREVIEW
(standards.iteh.ai)

ISO 527-4:2021

https://standards.iteh.ai/catalog/standards/iso-527-4-2021
Figure 1 — Stress-strain curve

3.8 Poisson's ratio

μ
negative ratio of the strain change $\Delta\epsilon_n$, in one of the two axes normal to the direction of extension, to the corresponding strain change $\Delta\epsilon_l$ in the direction of extension, within the linear portion of the longitudinal versus normal strain curve

Note 1 to entry: It is expressed as a dimensionless ratio.

Note 2 to entry: Since the lateral strain change $\Delta\epsilon_n$ is a negative number and the longitudinal strain change $\Delta\epsilon_l$ is positive, the Poissons ratio as defined in ISO 527-1:2019, 3.10 is a positive number.

[SOURCE: ISO 527-1:2019, 3.10]

3.9 specimen coordinate axes

axes, where "1"-direction is normally defined in terms of a feature associated with the material structure or the production process, such as the length direction in continuous-sheet processes (see [Figure 2](#)) and the "2"-direction is perpendicular to the "1"-direction.

Note 1 to entry: The "1-direction is also referred to as the 0° or longitudinal direction and the "2"-direction as the 90° or transverse direction. The "3-direction" is perpendicular to the plane of the "1-direction" and "2-direction". The "3-direction" is also referred to as the "through-thickness" direction for planar systems.

Note 2 to entry: For unidirectional materials covered by part 5 of this International Standard, the direction parallel to the fibres is defined as the "1"-direction and the direction perpendicular to the fibres (in the plane of the prepreg/plate) as the "2"-direction.

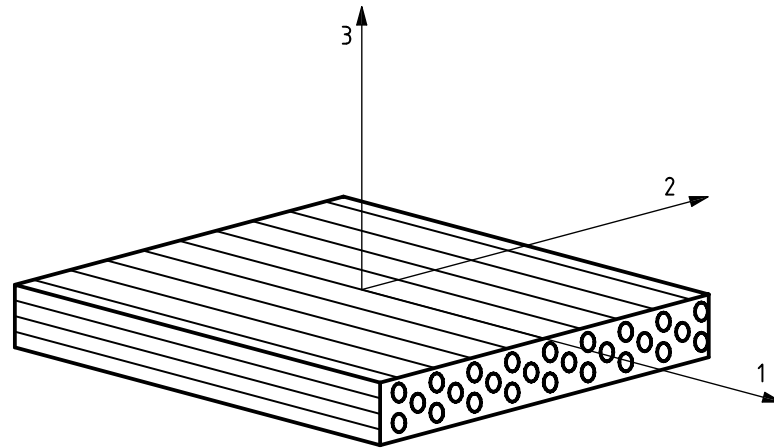

Figure 2 — Fibre-reinforced plastic composite showing axes of symmetry

3.10 failure position

u_F
failure location of specimen type 4 within the local coordinate system (u, v) of the tapered section

Note 1 to entry: It is expressed in millimetres (mm).

Note 2 to entry: See [Figure 5](#).

4 Principle

According to ISO 527-1.

[ISO 527-4:2021](#)

<https://standards.iteh.ai/catalog/standards/sist/c08bf202-523f-49f0-9df7-3a7b7bd241c/iso-527-4-2021>

5 Apparatus

The apparatus shall conform to ISO 527-1:2019, Clause 5, except for the following:

The micrometre or its equivalent (see ISO 16012: 2015, 5.5) shall read to 0,01 mm or better. It shall have a suitable-size ball-ended anvil if used on irregular surfaces and a flat anvil if used on flat, smooth (e.g. machined) surfaces.

When using extensometers with specimen type 4, use a gauge length of 25 mm (see ISO 527-1:2019, 5.1.5).

It is recommended to check alignment of the specimen and loading train as described in [Annex A](#).

6 Test specimens

6.1 Shape and dimensions

Four types of test specimen are specified for use with this document, as detailed and illustrated in [Figure 3](#) (type 1 B), [Figure 4](#) (types 2 and 3) and [Figure 5](#) (type 4).

Type 1B is for testing fibre-reinforced thermoplastics. Type 1B specimens may also be used for fibre-reinforced thermosets if they break within the gauge length. Type 1B shall not be used for multidirectional, continuous-fibre-reinforced materials.

Type 2 is rectangular without end-tabs, and Type 3 is rectangular with bonded end-tabs. They are for testing fibre reinforced thermosets and thermoplastics. Specimens with unbonded end tabs are considered as type 2.

ISO 527-4:2021(E)

The preferred width of type 2 and type 3 specimens is 25 mm, but widths of 50 mm or greater may be used if the tensile strength is low due to the particular type of reinforcement used.

Type 4 is tapered without end-tabs and for testing fibre-reinforced composites, especially for testing multidirectional, continuous-fibre reinforced thermoplastics. Please refer to [Annex B](#).

The thickness of type 2, type 3 and type 4 specimens shall be between 2 mm and 10 mm.

To decide whether to use specimen with or without tabs, first carry out tests without using tabs (specimen type 2 [rectangle] or type 4 [tapered]) and, if the tests are not successful, i.e. if almost all specimens break in the grips (see [Clause 7](#)), perform test with bonded end tabs on the specimens (specimen type 3). Refer to [Annex C](#) for guidance on unbonded tabs or gripping condition without tabs using fine grip faces and careful control of the gripping force.

NOTE Continuous fibre reinforced composites typically have high fracture forces due to high tensile strength of their fibres. Using specimen thicknesses larger than 4 mm can require an increased clamping length to counter high clamping pressures.

The recommended specimen thickness for continuous-fibre-reinforced composites is 2 mm. For compression-moulded materials, the thickness between the end-pieces of any type of specimen shall at no point deviate from the mean by more than 2 %.

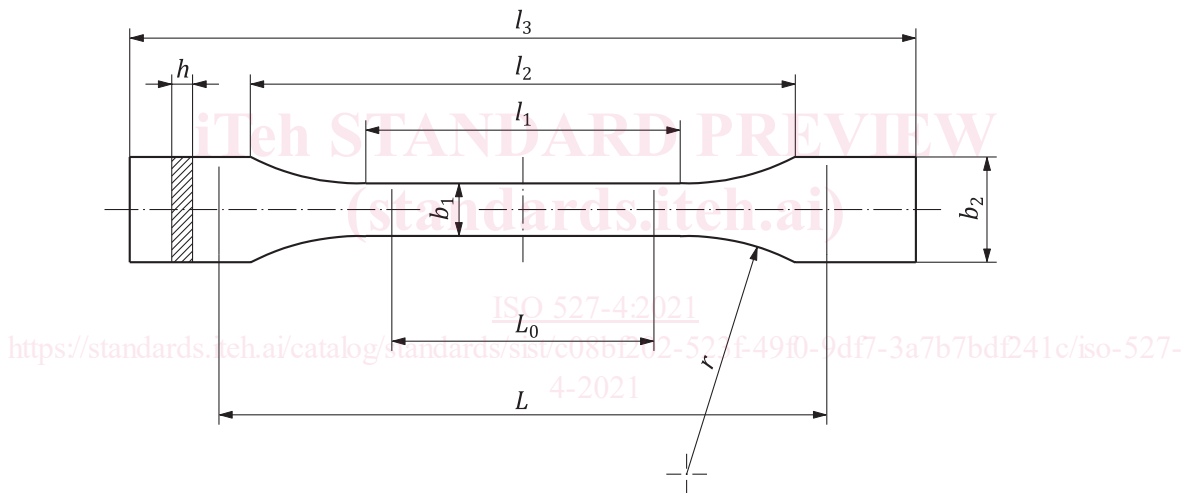

| Symbol | Name | Dimensions in millimetres |
|--------|--|---------------------------|
| l_3 | Overall length ^a | ≥ 150 |
| l_1 | Length of narrow parallel-sided portion | $60,0 \pm 0,5$ |
| r | Radius ^b | ≥ 60 |
| b_2 | Width at ends | $20,0 \pm 0,2$ |
| b_1 | Width of narrow portion | $10,0 \pm 0,2$ |
| h | Thickness | 2 to 10 |
| L_0 | Gauge length (recommended for extensometers) | $50,0 \pm 0,5$ |
| L | Initial distance between grips | 115 ± 1 |

^a For some materials, the length of the tabs can be extended (e.g. so that $l_3 = 200$ mm) to prevent breakage or slippage of the specimen in the jaws.

^b It should be noted that a thickness of 4 mm gives a specimen which is identical to the type 1B specimen specified in ISO 527-2.

Figure 3 — Type 1B specimen