**Plastics — Determination of tensile
properties —**

**Part 5:
Test conditions for unidirectional
fibre-reinforced plastic composites**

iTeh STANDARD PREVIEW
Plastiques — Détermination des propriétés en traction —
(standards.iteh.ai) **Partie 5: Conditions d'essai pour les composites plastiques renforcés
de fibres unidirectionnelles**

[ISO 527-5:2021](https://standards.iteh.ai/catalog/standards/sist/72aff91f-2b8b-4371-9624-ebc450940cfl/iso-527-5-2021)

[https://standards.iteh.ai/catalog/standards/sist/72aff91f-2b8b-4371-9624-
ebc450940cfl/iso-527-5-2021](https://standards.iteh.ai/catalog/standards/sist/72aff91f-2b8b-4371-9624-ebc450940cfl/iso-527-5-2021)



iTeh STANDARD PREVIEW
(standards.iteh.ai)

[ISO 527-5:2021](https://standards.iteh.ai/catalog/standards/sist/72aff91f-2b8b-4371-9624-ebc450940cfl/iso-527-5-2021)

[https://standards.iteh.ai/catalog/standards/sist/72aff91f-2b8b-4371-9624-
ebc450940cfl/iso-527-5-2021](https://standards.iteh.ai/catalog/standards/sist/72aff91f-2b8b-4371-9624-ebc450940cfl/iso-527-5-2021)



COPYRIGHT PROTECTED DOCUMENT

© ISO 2021

All rights reserved. Unless otherwise specified, or required in the context of its implementation, no part of this publication may be reproduced or utilized otherwise in any form or by any means, electronic or mechanical, including photocopying, or posting on the internet or an intranet, without prior written permission. Permission can be requested from either ISO at the address below or ISO's member body in the country of the requester.

ISO copyright office
CP 401 • Ch. de Blandonnet 8
CH-1214 Vernier, Geneva
Phone: +41 22 749 01 11
Email: copyright@iso.org
Website: www.iso.org

Published in Switzerland

Contents

	Page
Foreword.....	iv
1 Scope	1
2 Normative references	1
3 Terms and definitions	1
4 Principle	5
5 Apparatus	5
6 Test specimens	5
6.1 Shape and dimensions.....	5
6.1.1 General.....	5
6.1.2 Type A specimen (for longitudinal direction).....	7
6.1.3 Type B specimen (for transverse direction).....	7
6.2 Preparation of specimens.....	7
6.2.1 General.....	7
6.2.2 End tabs.....	7
6.2.3 Application of end tabs.....	7
6.3 Gauge marks.....	7
6.4 Checking the specimens.....	7
7 Number of specimens	8
8 Conditioning	8
9 Procedure	8
9.1 Test atmosphere.....	8
9.2 Measurement of specimen dimensions.....	8
9.3 Clamping.....	8
9.4 Prestresses.....	8
9.5 Setting of extensometers and strain gauges and placing of gauge marks.....	8
9.6 Test speed.....	8
9.7 Recording of data.....	8
10 Calculation and expression of results	8
10.1 Calculation of all properties for parallel sided specimens (Type A and B).....	8
11 Precision	9
12 Test report	9
Annex A (informative) Alignment of specimens	10
Annex B (informative) Use of unbonded tabs and conditions for gripping tab-less specimens using fine grip faces	12
Annex C (normative) Specimen preparation for type A and type B	15
Bibliography	17

Foreword

ISO (the International Organization for Standardization) is a worldwide federation of national standards bodies (ISO member bodies). The work of preparing International Standards is normally carried out through ISO technical committees. Each member body interested in a subject for which a technical committee has been established has the right to be represented on that committee. International organizations, governmental and non-governmental, in liaison with ISO, also take part in the work. ISO collaborates closely with the International Electrotechnical Commission (IEC) on all matters of electrotechnical standardization.

The procedures used to develop this document and those intended for its further maintenance are described in the ISO/IEC Directives, Part 1. In particular, the different approval criteria needed for the different types of ISO documents should be noted. This document was drafted in accordance with the editorial rules of the ISO/IEC Directives, Part 2 (see www.iso.org/directives).

Attention is drawn to the possibility that some of the elements of this document may be the subject of patent rights. ISO shall not be held responsible for identifying any or all such patent rights. Details of any patent rights identified during the development of the document will be in the Introduction and/or on the ISO list of patent declarations received (see www.iso.org/patents).

Any trade name used in this document is information given for the convenience of users and does not constitute an endorsement.

For an explanation of the voluntary nature of standards, the meaning of ISO specific terms and expressions related to conformity assessment, as well as information about ISO's adherence to the World Trade Organization (WTO) principles in the Technical Barriers to Trade (TBT), see www.iso.org/iso/foreword.html.

This document was prepared by Technical Committee ISO/TC 61, *Plastics*, Subcommittee SC 13, *Composites and reinforcement fibres*, in collaboration with the European Committee for Standardization (CEN) Technical Committee CEN/TC 249, *Plastics*, in accordance with the Agreement on technical cooperation between ISO and CEN (Vienna Agreement).

This third edition cancels and replaces the second edition (ISO 527-5:2009), which has been technically revised. The main changes compared to the previous edition are as follows:

- gripping force or pressure (e.g. via torque or manometer depending on gripping system used) has been adjusted;
- a new [Annex B](#) (Use of unbonded tabs and conditions for gripping tab-less specimens using fine grip faces) has been added.

A list of all parts in the ISO 527 series can be found on the ISO website.

Any feedback or questions on this document should be directed to the user's national standards body. A complete listing of these bodies can be found at www.iso.org/members.html.

Plastics — Determination of tensile properties —

Part 5:

Test conditions for unidirectional fibre-reinforced plastic composites

1 Scope

This document specifies the test conditions for the determination of the tensile properties of unidirectional fibre-reinforced plastic composites, based upon the general principles given in ISO 527-1.

NOTE Isotropic and orthotropic reinforced materials are covered by ISO 527-4.

The methods are used to investigate the tensile behaviour of the test specimens and for determining the tensile strength, tensile modulus, Poisson's ratios and other aspects of the tensile stress-strain relationship under the conditions defined.

The test method is suitable for all polymer matrix systems reinforced with unidirectional fibres and which meet the requirements, including failure mode, set out in this document.

The method is suitable for composites with either thermoplastic or thermosetting matrices, including preimpregnated materials (prepregs). The reinforcements covered include carbon fibres, glass fibres, aramid fibres and other similar fibres. The reinforcement geometries covered include unidirectional (i.e. completely aligned) fibres and rovings and unidirectional fabrics and tapes.

The method is not normally suitable for multidirectional materials composed of several unidirectional layers at different angles (see ISO 527-4).

2 Normative references

The following documents are referred to in the text in such a way that some or all of their content constitutes requirements of this document. For dated references, only the edition cited applies. For undated references, the latest edition of the referenced document (including any amendments) applies.

ISO 527-1:2019, *Plastics — Determination of tensile properties — Part 1: General principles*

ISO 1268 (all parts), *Fibre-reinforced plastics — Methods of producing test plates*

ISO 2818, *Plastics — Preparation of test specimens by machining*

ISO 16012, *Plastics — Determination of linear dimensions of test specimens*

3 Terms and definitions

For the purposes of this document, the following terms and definitions apply.

ISO and IEC maintain terminological databases for use in standardization at the following addresses:

- ISO Online browsing platform: available at <https://www.iso.org/obp>
- IEC Electropedia: available at <https://www.electropedia.org/>

**3.1
gauge length**

L_0
initial distance between the gauge marks on the central part of the test specimen

Note 1 to entry: It is expressed in millimetres (mm).

Note 2 to entry: The values of the gauge length that are indicated for the specimen types in the different parts of ISO 527 represent the maximum relevant gauge length.

[SOURCE: ISO 527-1:2019, 3.1]

**3.2
thickness**

h
smaller initial dimension of the rectangular cross-section in the central part of a test specimen

Note 1 to entry: It is expressed in millimetres (mm).

[SOURCE: ISO 527-1:2019, 3.2]

**3.3
width**

b_1
larger initial dimension of the rectangular cross-section in the central part of a test specimen

Note 1 to entry: It is expressed in millimetres (mm).

[SOURCE: ISO 527-1:2019, 3.3]

**3.4
test speed**

v
rate of separation of the gripping jaws

ISO 527-5:2021
<https://standards.iteh.ai/catalog/standards/sist/72aff91f-2b8b-4371-9624-ebc450940cfl/iso-527-5-2021>

Note 1 to entry: It is expressed in millimetres per minute (mm/min).

[SOURCE: ISO 527-1:2019, 3.5]

**3.5
stress**

σ
normal force per unit area of the original cross-section within the *gauge length* (3.1)

Note 1 to entry: It is expressed in megapascals (MPa).

Note 2 to entry: In order to differentiate from the true stress related to the actual cross-section of the specimen, this stress is frequently called “engineering stress”.

Note 3 to entry: σ for type A specimens is defined as σ_1 and for type B specimens as σ_2 (see 3.9, Figure 2 and Clause 6 for definitions of these directions).

[SOURCE: ISO 527-1:2019, 3.6, modified — Domain “<engineering>” and Note 3 to entry has been added.]

**3.5.1
strength**

σ_m
maximum stress observed during a tensile test

Note 1 to entry: It is expressed in megapascals (MPa).

Note 2 to entry: σ_m for type A specimens is defined as σ_{m1} and for type B specimens as σ_{m2} .

[SOURCE: ISO 527-1:2019, 3.6.2]

3.6 strain

ε
increase in length per unit original length of the gauge

Note 1 to entry: For type A specimens, ε is defined as ε_1 and for type B specimens as ε_2 .

Note 2 to entry: It is expressed as a dimensionless ratio, or as a percentage (%).

[SOURCE: ISO 527-1:2019, 3.7]

3.6.1 strain at strength failure strain

ε_m
strain at which the *strength* (3.5.1) is reached

Note 1 to entry: For type A specimens, ε_m is defined as ε_{m1} and for type B specimens as ε_{m2} .

Note 2 to entry: It is expressed as a dimensionless ratio, or as a percentage (%).

[SOURCE: ISO 527-1:2019, 3.7.3]

3.7 tensile modulus modulus of elasticity in tension

E
slope of the stress-strain curve $\sigma(\varepsilon)$ in the interval between the two strains $\varepsilon' = 0,05\%$ and $\varepsilon'' = 0,25\%$
(see [Figure 1](#))

Note 1 to entry: It is expressed in megapascals (MPa).
<https://standards.iteh.ai/catalog/standards/sist/72aff91f-2b8b-4371-9624-ebc450940cfl/iso-527-5-2021>

Note 2 to entry: It may be calculated either as the chord modulus or as the slope of a linear least-squares regression line in this interval.

Note 3 to entry: This definition does not apply to films.

Note 4 to entry: E for type A specimens is defined as E_1 and for type B specimens as E_2 .

[SOURCE: ISO 527-1:2019, 3.9.]

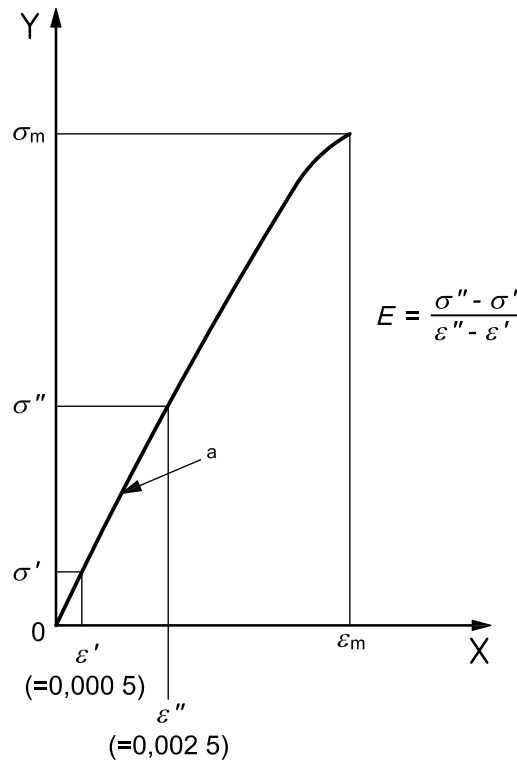

Key

- X strain, ϵ
- Y stress, σ
- a Slope E .

iTeh STANDARD PREVIEW
(standards.iteh.ai)

<https://standards.iteh.ai/catalog/standards/sist/72aff91f-2b8b-4371-9624-10c455000000/iso-527-5:2021>

<https://standards.iteh.ai/catalog/standards/sist/72aff91f-2b8b-4371-9624-10c455000000/iso-527-5:2021>

Figure 1 — Stress-strain curve

3.8 Poisson's ratio

μ
 negative ratio of the strain change $\Delta\epsilon_n$, in one of the two axes normal to the direction of extension, to the corresponding strain change $\Delta\epsilon_1$ in the direction of extension, within the linear portion of the longitudinal versus normal strain curve.

Note 1 to entry: It is expressed as a dimensionless ratio.

Note 2 to entry: Since the lateral strain change $\Delta\epsilon_n$ is a negative number and the longitudinal strain change $\Delta\epsilon_1$ is positive, the Poisson's ratio as defined in ISO 527-1:2019, 3.10 is a positive number.

Note 3 to entry: μ_{12} is the major Poisson's ratio of a UD composite, describing the dimensional change in 2-direction as a result of a load applied in 1-direction for type A specimens (see 3.9 and Figure 2).

Note 4 to entry: μ_{21} is the minor Poisson's ratio of a UD composite, describing the dimensional change in 1-direction as a result of a load applied in 2-direction for type B specimens (see 3.9 and Figure 2).

[SOURCE: ISO 527-1:2019, 3.10]

3.9 specimen coordinate axes

coordinate axes for the material under test, as shown in Figure 2, the direction parallel to the fibres being defined as the "1"-direction and the direction perpendicular to them (in the plane of the fibres) as the "2"-direction

Note 1 to entry: The "1"-direction is also referred to as the 0° or longitudinal direction and the "2"-direction as the 90° or transverse direction. See Figure 2.

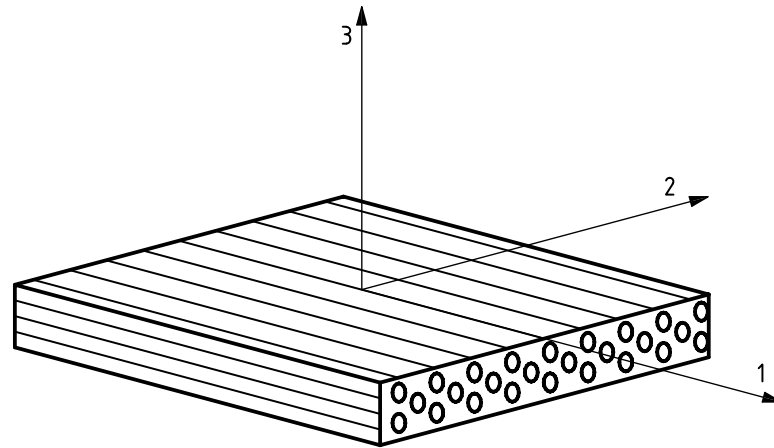

Figure 2 — Unidirectionally reinforced plastic composite showing axes of symmetry

4 Principle

According to ISO 527-1:2019, Clause 4.

5 Apparatus

The apparatus shall conform to ISO 527-1:2019, Clause 5, except for the following:

The micrometre or its equivalent (in accordance with ISO 16012:2015, 5.5) shall read to 0,01 mm or better. It shall have a suitable-size ball ended anvil if used on irregular surfaces and a flat anvil if used on flat, smooth (e.g. machined) surfaces.

Care shall be exercised to ensure that the pressure exerted by the grips (see ISO 527-1:2019, 5.1.3) is only sufficient to prevent the specimen slipping in the grip when loaded to failure. Excessive grip pressure may cause crushing of the specimen due to the low transverse strength of these materials. Hydraulic grips which can be set at a constant grip pressure are preferred.

If strain gauges bonded to the specimen are used, the errors produced by the transverse effect on the transverse gauge will generally be much larger for anisotropic composites than for metals, which are isotropic. Accurate measurement of Poisson's ratio requires correction for this effect.

It is recommended that alignment of the specimen and loading train be checked as described in [Annex A](#).

6 Test specimens

6.1 Shape and dimensions

6.1.1 General

The method is performed using one of two different types of test specimen, depending on the direction of the applied stress relative to the fibre direction. Two types of test specimen are specified for use with this document, depending on the direction of test relative to the fibre direction, as detailed and illustrated in [Figure 3](#). Type A is used for testing in direction parallel to the fibres with end tabs. Type B is used for testing in direction transverse to the fibres with end tabs. Type A and B can also be used with unbonded tabs or without tabs using fine grip faces and careful control of the gripping force (see [Annex B](#)).

To decide whether to use specimens with or without bonded tabs, initially carry out tests without using bonded tabs. If these tests are unsuccessful, i.e. if almost all specimens break in the grips (see [Clause 7](#)), perform tests on specimens with bonded end tabs.

In the following paragraphs, the specimen thicknesses are defined. If materials cannot be manufactured in the appropriate thickness because of unavoidable reasons, such as a higher area weight or manufacturing from pultrusion in a different thickness, the nearest possible thickness shall be chosen.

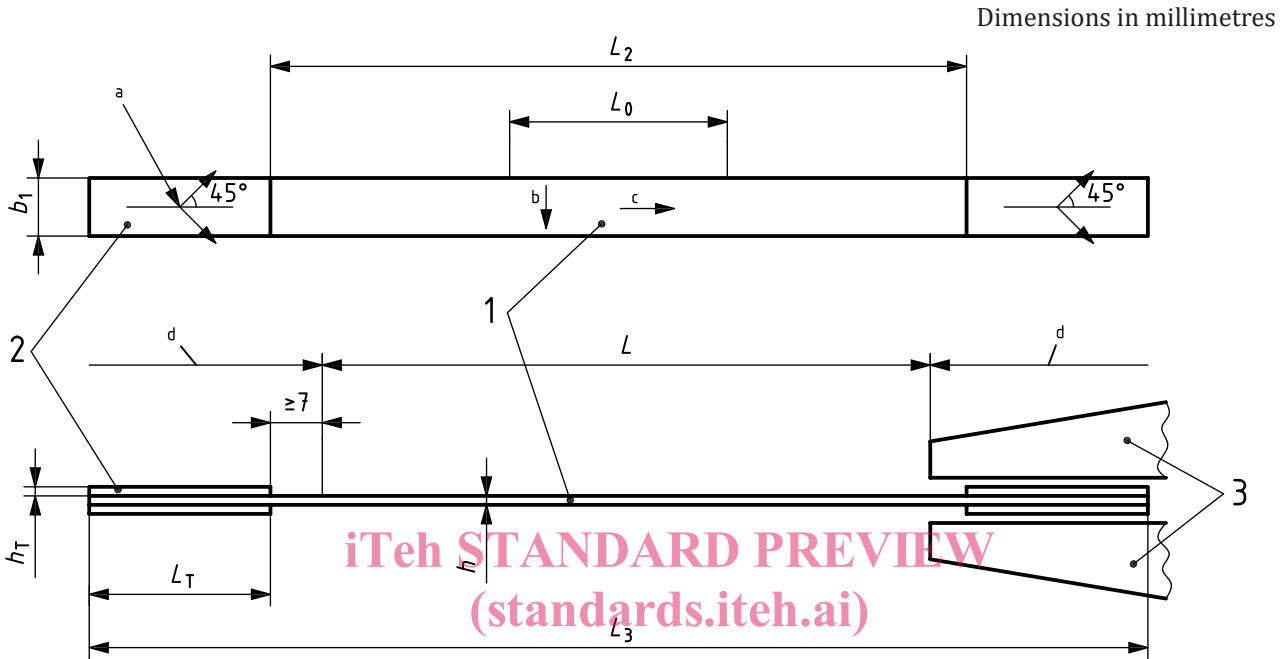

iTeh STANDARD PREVIEW
(standards.iteh.ai)

ISO 527-5:2021

<https://standards.iteh.ai/catalog/standards/sist/72aff91f-2b8b-4371-9624-ebc450940cfl/iso-527-5-2021>

Key

- 1 specimen
- 2 tab
- 3 jaws
- a Tab-fibre orientation.
- b Fibre direction in type B specimen.
- c Fibre direction in type A specimen.
- d Zone covered by jaws.

	Dimensions in millimetres	
	Type A	Type B
L_3 Overall length	≥ 250	≥ 250 (see Note 2)
L_2 Distance between end tabs	150 ± 1	150 ± 1
b_1 Width	$15 \pm 0,5$	$25 \pm 0,5$
h Thickness	$1 \pm 0,2$	$2 \pm 0,2$
L_0 Gauge length (recommended for extensometers)	50 ± 1	50 ± 1
L Initial distance between grips (nominal)	136	136
L_T Length of end tabs	> 50	> 50 (see NOTE 2)
h_T Thickness of end tabs	0,5 to 2	0,5 to 2

NOTE 1 Requirements on specimen quality and parallelism are given in ISO 527-1:2019, 6.4.

NOTE 2 For specimens taken from filament-wound plates prepared using ISO 1268-5, an overall specimen length of 200 mm is acceptable, with an end-tab length of 25 mm.

Figure 3 — Type A and type B specimens

6.1.2 Type A specimen (for longitudinal direction)

Type A specimens shall have a width of $15 \text{ mm} \pm 0,5 \text{ mm}$, an overall length of 250 mm and a thickness of $1 \text{ mm} \pm 0,2 \text{ mm}$ or, for specimens from filament-wound test plates, a thickness of $2 \text{ mm} \pm 0,2 \text{ mm}$. The sides of each individual specimen shall be parallel to within 0,2 mm.

6.1.3 Type B specimen (for transverse direction)

Type B specimens shall have a width of $25 \text{ mm} \pm 0,5 \text{ mm}$, an overall length of 250 mm and a thickness of $2 \text{ mm} \pm 0,2 \text{ mm}$. The sides of each individual specimen shall be parallel to within 0,2 mm.

For type B specimens taken from filament-wound plates prepared using ISO 1268-5, a test specimen length of 200 mm is acceptable.

6.2 Preparation of specimens

6.2.1 General

In the case of moulding and lamination materials, prepare a test plate in accordance with the relevant part of ISO 1268 or another specified/agreed procedure. Cut individual specimens, or groups of specimens (see [Annex C](#)), from the test plate.

In the case of finished products (for example, for quality control during manufacture or on delivery), take specimens from flat areas.

Take all specimens with their axis within $0,5^\circ$ of the mean fibre axis.

Parameters for machining specimens shall be as specified in ISO 2818. Further guidance on cutting out specimens is given in [Annex C](#).

6.2.2 End tabs

<https://standards.iteh.ai/catalog/standards/sist/72aff91f-2b8b-4371-9624-ebc450940cfl/iso-527-5-2021>

The ends of the specimen type A and B shall be reinforced with end tabs, preferably made of cross-ply or fabric glass-fibre/resin laminate with the fibres at $\pm 45^\circ$ to the specimen axis. The tab thickness shall be between 0,5 mm and 2 mm, with a tab angle of 90° (i.e. not tapered).

Alternative tabbing arrangements are permissible, but shall be shown, before use, to give at least equal strength and no greater coefficient of variation (see ISO 527-1:2019, 10.5 and ISO 3534-1^[1]) than the recommended tabs. Possible alternatives include tabs made from the material under test, mechanically fastened tabs, unbonded tabs made of rough materials (such as emery paper or sandpaper, and the use of roughened grip faces), and fine grip faces without tabs as described in [Annex B](#).

If the test is carried out on untabbed specimens, the distance between the grips shall be the same as that between the tabs of tabbed specimens. Care should be given to the contact part at the edge of grip faces.

6.2.3 Application of end tabs

Bond the end tabs to the specimen with a high-stretch adhesive in accordance with [Annex C](#).

NOTE The same procedure can be used for individual specimens and for a group of specimens.

6.3 Gauge marks

Gauge marks shall be in accordance with ISO 527-1:2019, 6.3.

6.4 Checking the specimens

Checking of specimens shall conform to ISO 527-1:2019, 6.4.