



# Standard Specification for Poly(Vinyl Chloride) (PVC) Plastic Drain, Waste, and Vent Pipe and Fittings<sup>1</sup>

This standard is issued under the fixed designation D2665; the number immediately following the designation indicates the year of original adoption or, in the case of revision, the year of last revision. A number in parentheses indicates the year of last reapproval. A superscript epsilon ( $\epsilon$ ) indicates an editorial change since the last revision or reapproval.

*This standard has been approved for use by agencies of the Department of Defense.*

## 1. Scope\*

1.1 This specification covers requirements and test methods for materials, dimensions and tolerances, pipe stiffness, crush resistance, impact resistance, and solvent cement for poly(vinyl chloride) plastic drain, waste, and vent pipe and fittings. A form of marking is also included. Plastic which does not meet the material requirements specified in Section 5 is excluded. Installation procedures are given in the Appendix.

1.2 The values stated in inch-pound units are to be regarded as standard. The values given in parentheses are mathematical conversions to SI units that are provided for information only and are not considered standard.

1.3 The text of this specification references notes, footnotes, and appendixes which provide explanatory material. These notes and footnotes (excluding those in tables and figures) shall not be considered as requirements of the specification.

1.4 The following safety hazards caveat pertains only to the test methods portion, Section 7, of this specification: *This standard does not purport to address all of the safety concerns, if any, associated with its use. It is the responsibility of the user of this standard to establish appropriate safety and health practices and determine the applicability of regulatory limitations prior to use.*

## 2. Referenced Documents

### 2.1 ASTM Standards:<sup>2</sup>

D618 Practice for Conditioning Plastics for Testing

D1600 Terminology for Abbreviated Terms Relating to Plastics

D1784 Specification for Rigid Poly(Vinyl Chloride) (PVC) Compounds and Chlorinated Poly(Vinyl Chloride) (CPVC) Compounds

D2122 Test Method for Determining Dimensions of Thermoplastic Pipe and Fittings

D2412 Test Method for Determination of External Loading Characteristics of Plastic Pipe by Parallel-Plate Loading

D2444 Test Method for Determination of the Impact Resistance of Thermoplastic Pipe and Fittings by Means of a Tup (Falling Weight)

D2564 Specification for Solvent Cements for Poly(Vinyl Chloride) (PVC) Plastic Piping Systems

D3311 Specification for Drain, Waste, and Vent (DWV) Plastic Fittings Patterns ~~D4396 Specification for Rigid Poly(Vinyl Chloride) (PVC) and Chlorinated Poly(Vinyl Chloride) (CPVC) Compounds for Plastic Pipe and Fittings Used in Nonpressure Applications~~

F402 Practice for Safe Handling of Solvent Cements, Primers, and Cleaners Used for Joining Thermoplastic Pipe and Fittings

F412 Terminology Relating to Plastic Piping Systems

F1498 Specification for Taper Pipe Threads 60 for Thermoplastic Pipe and Fittings

F1866 Specification for Poly (Vinyl Chloride) (PVC) Plastic Schedule 40 Drainage and DWV Fabricated Fittings

F2135 Specification for Molded Drain, Waste, and Vent (DWV) Short-Pattern Plastic Fittings

## 3. Terminology

3.1 *Definitions*—Definitions are in accordance with Terminology F412, and abbreviations are in accordance with Terminology D1600, unless otherwise specified.

<sup>1</sup> This specification is under the jurisdiction of ASTM Committee F17 on Plastic Piping Systems and is the direct responsibility of Subcommittee F17.63 on DWV. Current edition approved Aug. April 1, 2011/2012 Published August 2011/May 2012. Originally approved in 1968. Last previous edition approved in 2010/2011 as D2665 - 10/1. DOI: 10.1520/D2665-11/2.

<sup>2</sup> For referenced ASTM standards, visit the ASTM website, www.astm.org, or contact ASTM Customer Service at service@astm.org. For *Annual Book of ASTM Standards* volume information, refer to the standard's Document Summary page on the ASTM website.

\*A Summary of Changes section appears at the end of this standard.

#### 4. Significance and Use

4.1 The requirements of this specification are intended to provide pipe and fittings suitable for the drainage and venting of sewage and certain other liquid wastes.

NOTE 1—Industrial waste disposal lines should be installed only with the specific approval of the cognizant building code authority since chemicals not commonly found in drains and sewers and temperatures in excess of 180°F (82.2°C) may be encountered.

NOTE 2—This specification does not include requirements for pipe and fittings intended to be used to vent combustion gases.

#### 5. Materials

5.1 *Basic Materials*—The pipe shall be made of virgin PVC compounds meeting or exceeding the requirements of Class 12454 as defined in Specification D1784. The fittings shall be made of virgin PVC compounds meeting or exceeding the requirements of Class 12454/12344 as defined in Specification D1784 or Class 11432 as defined in Specification D4396. ~~These plastics contain stabilizers, lubricants, and pigments.~~ These plastics contain stabilizers, lubricants, and pigments.

5.2 *Rework Material*—The manufacturer shall use only his own clean pipe or fitting rework material, and the pipe or fittings produced shall meet all the requirements of this specification.

5.3 *Solvent Cement*—The solvent cement used to join pipe and fittings made to this specification shall meet the requirements of Specification D2564.

#### 6. Requirements

6.1 *General*—The pipe and fittings shall be homogeneous throughout and free of visible cracks, holes, foreign inclusions, or other injurious defects. The pipe shall be as uniform as commercially practicable in color, opacity, density, and other physical properties.

6.1.1 The requirements in this section are intended only for use as quality control tests, not as simulated service tests.

6.2 *Dimensions and Tolerances:*

6.2.1 *Method*—All dimensions shall be determined in accordance with Test Method D2122.

6.2.2 *Dimensions:*

6.2.2.1 The outside diameter and wall thicknesses of pipe shall meet the requirements of Table 2. The pipe shall be in either 10 or 20-ft (3.05 or 6.1-m) lengths, unless otherwise specified, with an allowable tolerance of +½ , -0 in. (+13, -0 mm).

6.2.2.2 The patterns, dimensions, and laying lengths of fittings, including adaptors, shall meet the requirements of Specification D3311 and Table 1.

6.2.2.3 Reducer bushings of sizes 2 by 1¼ and 4 by 3 shall be permitted to have the socket wall thickness and spigot wall thickness below the minimum requirements defined in Table 1, but not less than 0.098 in. (2.5 mm), provided the inner socket and outer spigot are reinforced by a minimum of four ribs. The thickness of the supporting ribs shall not be less than 0.098 in. (2.5 mm).

6.2.2.4 The patterns, dimensions, and laying lengths of Short-Pattern fittings shall meet the requirements of Specification F2135.

6.2.2.5 For all fittings having taper pipe threads, threads shall conform to Specification F1498 and be gaged in accordance with 7.5. Fittings of nominal sizes not given in Specification F1498 shall not have threads.

6.2.2.6 Fabricated DWV fittings shall comply with Specification F1866.

6.3 *Pipe Stiffness, Deflection Load and Flattening:*

6.3.1 *Pipe*—The minimum pipe stiffness at 5 % deflection shall be in accordance with Table 3. The pipe shall deflect by 60 % of the nominal outside diameter (flattening) without cracking, rupture, or other visible evidence of failure when tested in accordance with 7.4.

6.3.1.1 *Pipe Stiffness (PS)*—Three specimens shall be tested. If all three meet the PS requirement, the sample meets the PS requirement. If one or two fail, additional testing shall be conducted in accordance with 6.3.1.2. If all three fail, the sample does not meet the PS requirement.

6.3.1.2 *Pipe Stiffness and Lower Confidence Limit*—In the event that one or two of the specimens tested in 6.3.1 fail to meet the minimum PS requirement, the average pipe stiffness of eleven specimens shall meet or exceed the minimum requirement given in Table 3. The 99 % lower confidence limit (LCL) shall be within 15 % of the average value. The LCL shall be calculated using the Student's "t" distribution, with N-1 degrees of freedom, where N is the number of specimens. The critical t value shall be used to at least three significant digits. Alternatively, if the LCL exceeds the minimum PS requirement in Table 3, but is not within 15 % of the average, the sample meets the requirements of the pipe stiffness testing. The eleven specimens include the three tested under 6.3.1, and an additional eight with rotation by 35°, as specified in Test Method D2412, continuing throughout the remaining specimens.

6.3.1.3 The LCL based on testing eleven specimens is calculated as follows:

$$LCL = (\text{avg PS}) - \{2.76(\text{std. dev.})/\sqrt{(N)}\} \quad (1)$$

D2665-12\_1

where:

D2665-12\_2

TABLE 1 Dimensions and Tolerances for Fitting Sockets for PVC Schedule 40 Drain, Waste and Vent Pipe Fittings

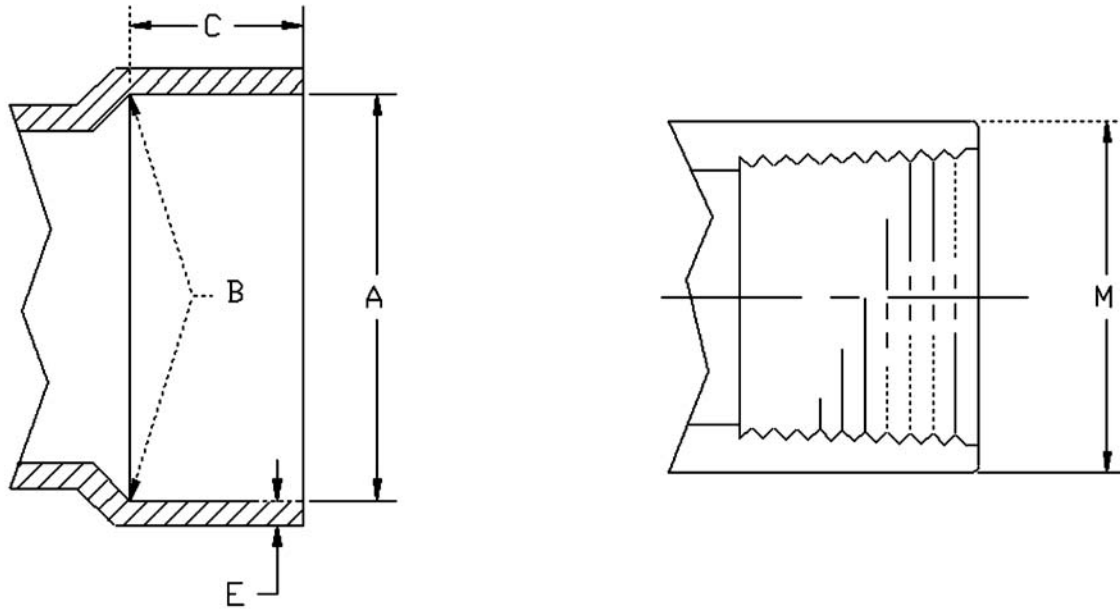

Nominal Pipe Size	A			B			C	E	M			
	Socket Entrance Diameter			Socket Bottom Diameter					Socket Depth, min	Wall thickness min. <sup>A</sup>	Internal Threads	
	Average	Tolerance on Avg.	Out-of-Roundness	Average	Tolerance on Avg.	Out-of-Roundness					Outside Diameter of Hub, M, min.	Thread length min.
	in. (mm)											
1¼	1.675 (42.54)	+0.010/-0.005 (+0.25/-0.13)	0.024 (0.61)	1.655 (42.04)	±0.005 (±0.13)	0.024 (0.61)	0.687 (17.44)	0.156 (3.96)	1.871 (47.52)	0.687 (17.44)		
1½	1.915 (48.64)	+0.010/-0.005 (+0.25/-0.13)	0.024 (0.61)	1.894 (48.11)	±0.006 (±0.15)	0.024 (0.61)	0.687 (17.44)	0.156 (3.96)	2.127 (54.03)	0.687 (17.44)		
2	2.390 (60.71)	+0.010/-0.005 (+0.25/-0.13)	0.024 (0.61)	2.369 (60.17)	±0.006 (±0.15)	0.024 (0.61)	0.750 (19.05)	0.156 (3.96)	2.634 (66.90)	0.750 (19.05)		
3	3.520 (89.41)	+0.010/-0.005 (+0.25/-0.13)	0.030 (0.76)	3.492 (88.70)	±0.008 (±0.20)	0.030 (0.76)	1.500 (38.10)	0.219 (5.56)	3.841 (97.56)	1.187 (30.15)		
4	4.520 (114.8)	+0.010/-0.005 (+0.25/-0.13)	0.030 (0.76)	4.491 (114.1)	±0.009 (±0.23)	0.030 (0.76)	1.750 (44.45)	0.250 (6.35)	4.907 (124.6)	1.28 (32.54)		
6	6.647 (168.8)	+0.015/-0.010 (+0.38/-0.25)	0.060 (1.52)	6.614 (168.0)	±0.011 (±0.28)	0.060 (1.52)	3.000 (76.20)	0.281 (7.14)	7.203 (183.0)	1.500 (38.10)		
8	8.655 (219.8)	+0.030/-0.000 (+0.76/-0.00)	0.090 (2.29)	8.610 (218.7)	±0.015 (±0.38)	0.090 (2.29)	4.000 (101.6)	0.328 (8.33)	<sup>B</sup>	<sup>B</sup>		
10	10.780 (273.8)	+0.025/-0.020 (+0.64/-0.51)	0.120 (3.05)	10.737 (272.7)	±0.015 (±0.38)	0.120 (3.04)	5.000 (127.0)	0.365 (9.28)	<sup>B</sup>	<sup>B</sup>		
12	12.780 (324.6)	+0.030/-0.025 (+0.76/-0.64)	0.150 (3.81)	12.736 (323.5)	±0.015 (±0.38)	0.150 (3.81)	6.000 (152.4)	0.406 (10.3)	<sup>B</sup>	<sup>B</sup>		

<sup>A</sup> The value for wall thickness shown in Table 1 is an averaged minimum. An averaged minimum is derived by adding two wall thicknesses that are directly opposite each other and dividing the result by 2. The reason for an averaged minimum wall thickness is due to core shift which is a normal occurrence found in fittings that are injection molded. When core shift occurs, the result is a pair of high and low wall thickness readings. The average of the high and the low wall thickness readings must equal or exceed the averaged minimum value shown in Table 1. The low wall thickness reading shall not be more than 10% below the averaged minimum value shown in Table 1. This applies to any point on the fitting (hub, body, or spigot). In cases where there is no opposite side (as in the case of a portion of the branch of a wye fitting) then the single wall thickness reading shall not be more than 10% below the averaged minimum value shown in Table 1.

<sup>B</sup> Not applicable for these nominal sizes.

**TABLE 2 Dimensions and Tolerances for Outside Diameters and Thicknesses of PVC Plastic Drain, Waste, and Vent Pipe**

Nominal Pipe Size	Outside Diameter			Wall Thickness	
	Average	Tolerance on Average	Out-of-Roundness (maximum minus minimum) in. (mm)	Minimum	Tolerance
1¼	1.660 (42.16)	±0.005 (0.13)	0.024 (0.61)	0.140 (3.56)	+0.020 (0.51) -0.000
1½	1.900 (48.26)	±0.006 (0.15)	0.024 (0.61)	0.145 (3.68)	+0.020 (0.51) -0.000
2	2.375 (60.33)	±0.006 (0.15)	0.024 (0.61)	0.154 (3.91)	+0.020 (0.51) -0.000
3	3.500 (88.90)	±0.008 (0.20)	0.030 (0.76)	0.216 (5.49)	+0.026 (0.66) -0.000
4	4.500 (114.30)	±0.009 (0.23)	0.100(2.54)	0.237 (6.02)	+0.028 (0.71) -0.000
6	6.625 (168.28)	±0.011 (0.28)	0.100 (2.54)	0.280 (7.11)	+0.034 (0.86) -0.000
8	8.625 (219.08)	±0.015 (0.38)	0.150 (3.81)	0.322 (8.18)	+0.039 (0.99) -0.000
10	10.750 (273.05)	±0.015 (0.38)	0.150 (3.81)	0.365 (9.27)	+0.044 (1.12) -0.000
12	12.750 (323.85)	±0.015 (0.38)	0.150 (3.81)	0.406 (10.31)	+0.049 (1.24) -0.000
14	14.000 (355.60)	±0.015 (±0.38)	0.200 (5.08)	0.437 (11.1)	+0.053 (1.35) -0.000
16	16.000 (406.40)	±0.019 (±0.48)	0.320 (8.13)	0.500 (12.7)	+0.060 (1.52) -0.000
18	18.000 (457.20)	±0.019 (±0.48)	0.360 (9.20)	0.562 (14.27)	+0.067 (1.71) -0.000
20	20.000 (508.00)	±0.023 (±0.58)	0.400 (10.20)	0.593 (15.06)	+0.071 (1.81) -0.000
24	24.000 (609.60)	±0.031 (±0.79)	0.480 (12.20)	0.687 (17.45)	+0.082 (2.09) -0.000

**TABLE 3 Pipe Stiffness Requirements for PVC DWV Pipe<sup>A</sup>**

Nominal Pipe Size, in.	Pipe Stiffness, min, psi (kPa)
1¼	1400 (9650)
1½	1010 (6960)
2	600 (4140)
3	510 (3520)
4	310 (2140)
6	150 (1030)
8	100 (690)
10	78 (530)
12	63 (430)
14	60 (415)
16	60 (415)
18	60 (415)
20	51 (350)
24	45 (315)

<sup>A</sup> Measured at 5 % deflection.

**D2665-12\_3**

N = 11

6.3.1.4 The 15 % requirement is calculated as follows:

**D2665-12\_4**

NOTE 3—The 5 % deflection criterion, which was arbitrarily selected for testing convenience, should not be considered as a limitation with respect to in-use deflection. The engineer is responsible for establishing the acceptable deflection.

6.3.2 *Fittings*—Individual fittings unassembled shall withstand a minimum load of 750 lbf/ft (11 kN/m) of centerline length without cracking or other visible evidence of failure when tested in accordance with 7.4.

6.4 *Impact Resistance*—The minimum impact resistance of pipe and fittings, when tested at the time of manufacture, shall comply with Table 4. Test in accordance with Test Method D2444 using Tup C and Holder A for pipe and Tup A and Holder B for fittings. Use a 12-lb (5-kg) tup for testing pipe sizes 4 in. and smaller and a 20-lb (10-kg) tup for pipe larger than 4 in. Test fittings with a 12-lb (5-kg) Tup. Test couplings cemented to short pieces of pipe and allowed to dry for 24 h. For fittings larger